

Unit 1/260 Carpenter Street

Created on
2019-03-26

Floors
1

▼ Ground Floor



▼ **Living Room**
Ground Floor

WIDTH: 4.50 m • LENGTH: 5.66 m
AREA: 19.62 m² • PERIMETER: 20.32 m

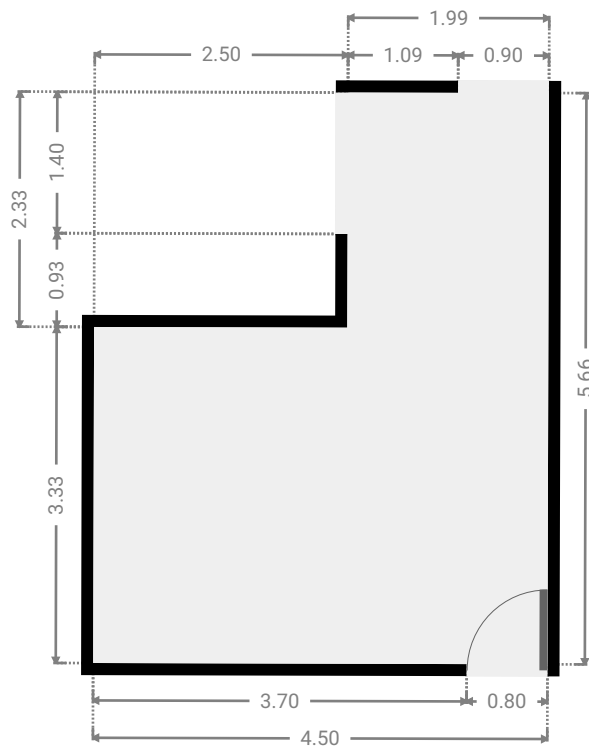
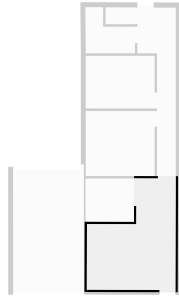

▼ **Kitchen**
Ground Floor

WIDTH: 2.51 m • LENGTH: 2.21 m
AREA: 5.54 m² • PERIMETER: 9.43 m

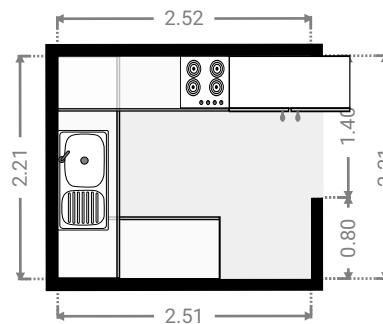
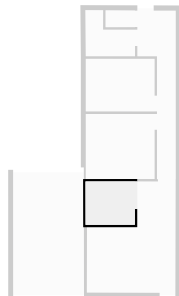

▼ **Bedroom**
Ground Floor

WIDTH: 3.50 m • LENGTH: 3.30 m
AREA: 11.56 m² • PERIMETER: 13.61 m

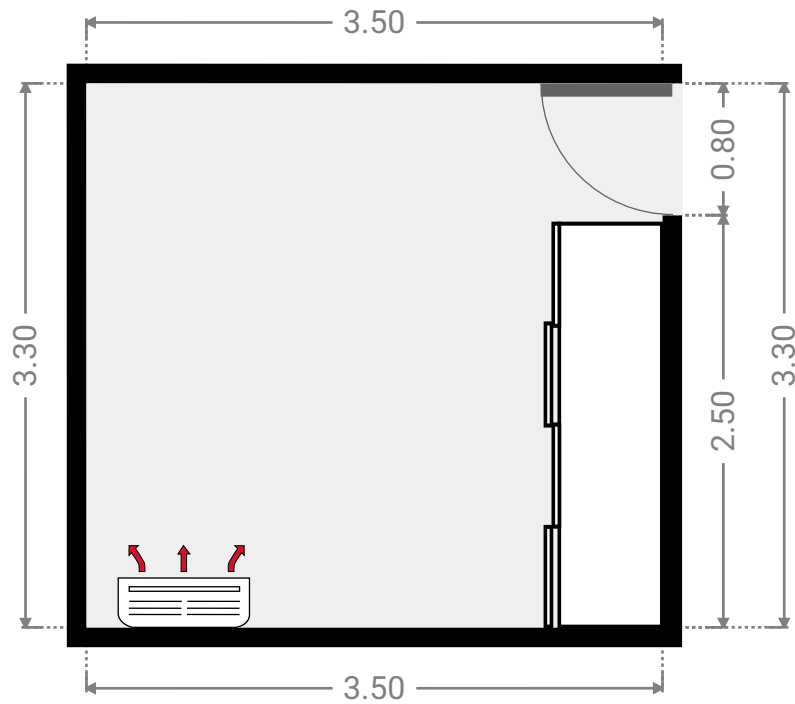
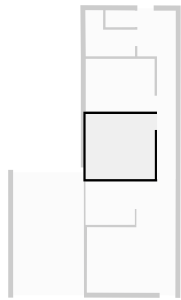

▼ **Bedroom**
Ground Floor

WIDTH: 3.50 m • LENGTH: 2.68 m
AREA: 9.36 m² • PERIMETER: 12.35 m

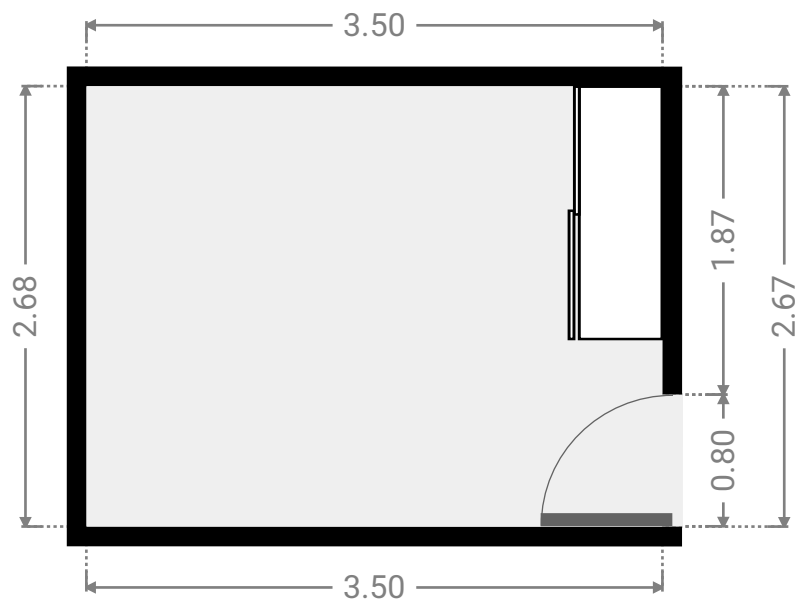
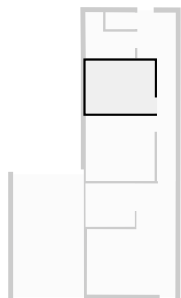

▼ Hall Ground Floor

WIDTH: 1.95 m • LENGTH: 8.57 m
AREA: 10.49 m² • PERIMETER: 21.04 m

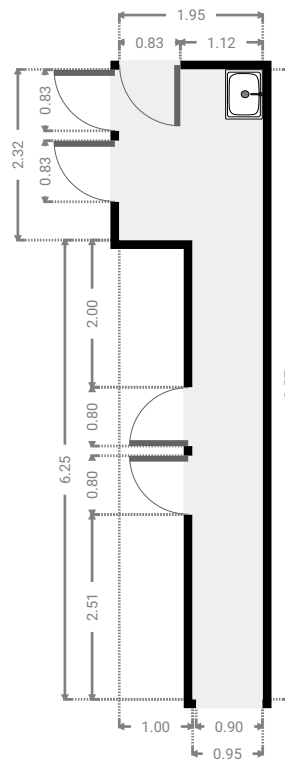
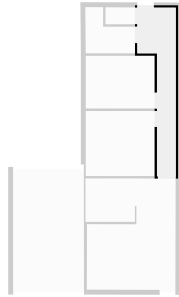

▼ Bathroom Ground Floor

WIDTH: 2.53 m • LENGTH: 2.35 m
AREA: 4.29 m² • PERIMETER: 9.72 m

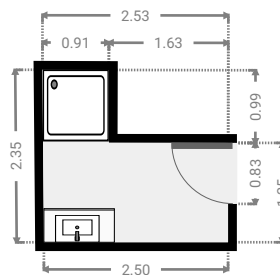
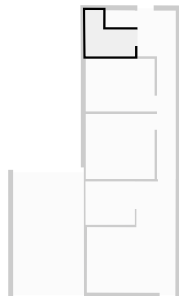

▼ **Toilet**
Ground Floor

WIDTH: 1.50 m • LENGTH: 0.87 m
AREA: 1.28 m² • PERIMETER: 4.71 m

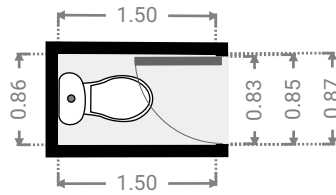
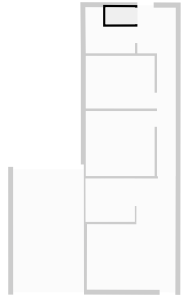

▼ **Carport**
Ground Floor

WIDTH: 3.60 m • LENGTH: 5.99 m
AREA: 21.56 m² • PERIMETER: 19.18 m

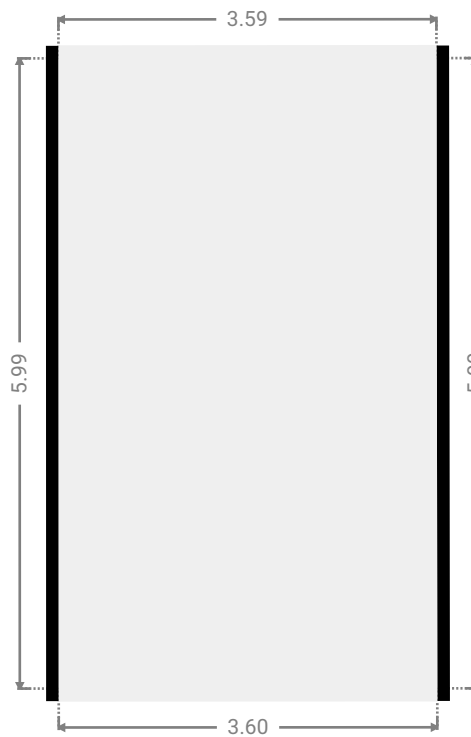
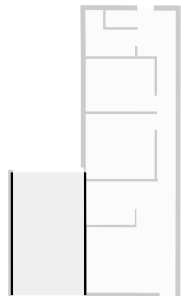

Unit 2/260 Carpenter Street

Created on
2018-11-01

Floors
1

▼ Ground Floor

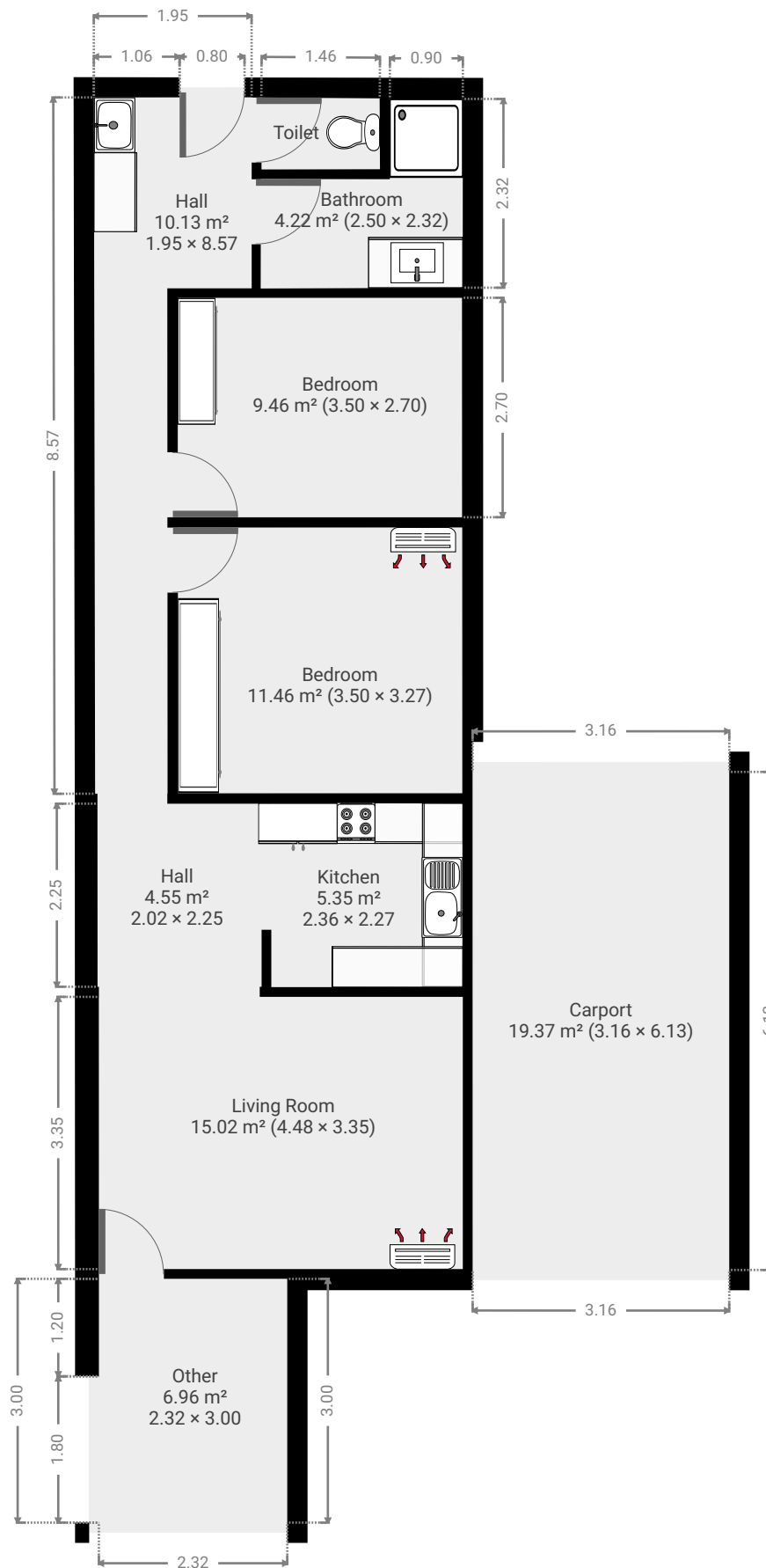

▼ **Living Room**
Ground Floor

WIDTH: 4.48 m • LENGTH: 3.35 m
AREA: 15.02 m² • PERIMETER: 15.67 m

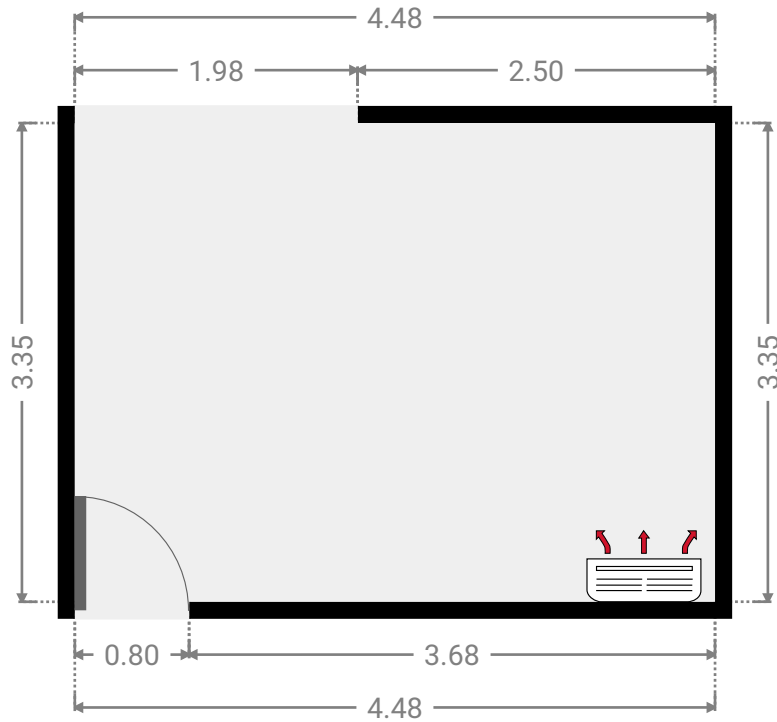
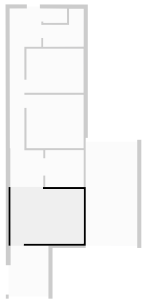

▼ **Hall**
Ground Floor

WIDTH: 2.02 m • LENGTH: 2.25 m
AREA: 4.55 m² • PERIMETER: 8.55 m

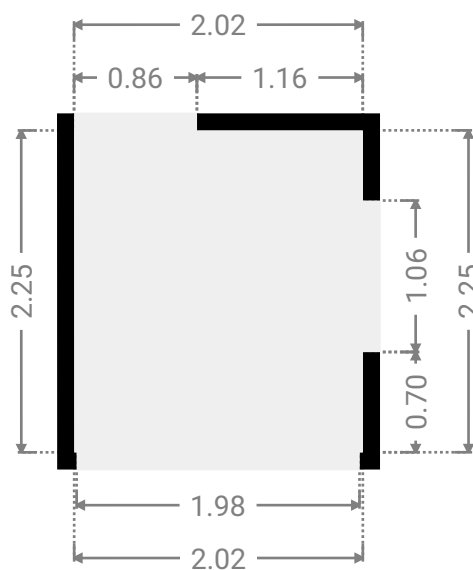
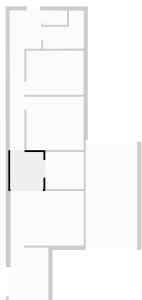

▼ **Kitchen**
Ground Floor

WIDTH: 2.36 m • LENGTH: 2.27 m
AREA: 5.35 m² • PERIMETER: 9.25 m

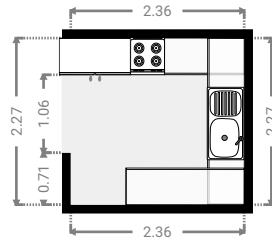
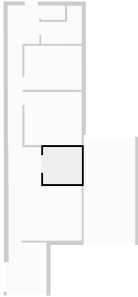

▼ **Hall**
Ground Floor

WIDTH: 1.95 m • LENGTH: 8.57 m
AREA: 10.13 m² • PERIMETER: 21.01 m

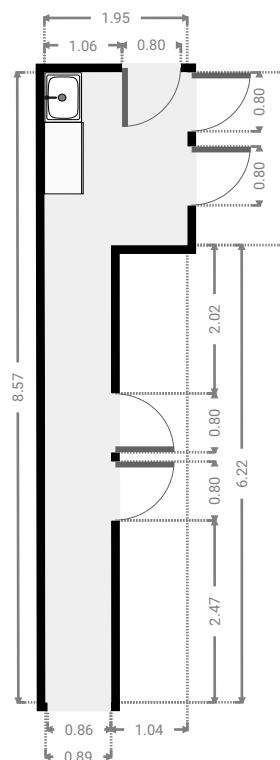
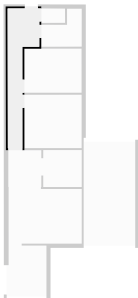

▼ **Bedroom**
Ground Floor

WIDTH: 3.50 m • LENGTH: 3.27 m
AREA: 11.46 m² • PERIMETER: 13.55 m

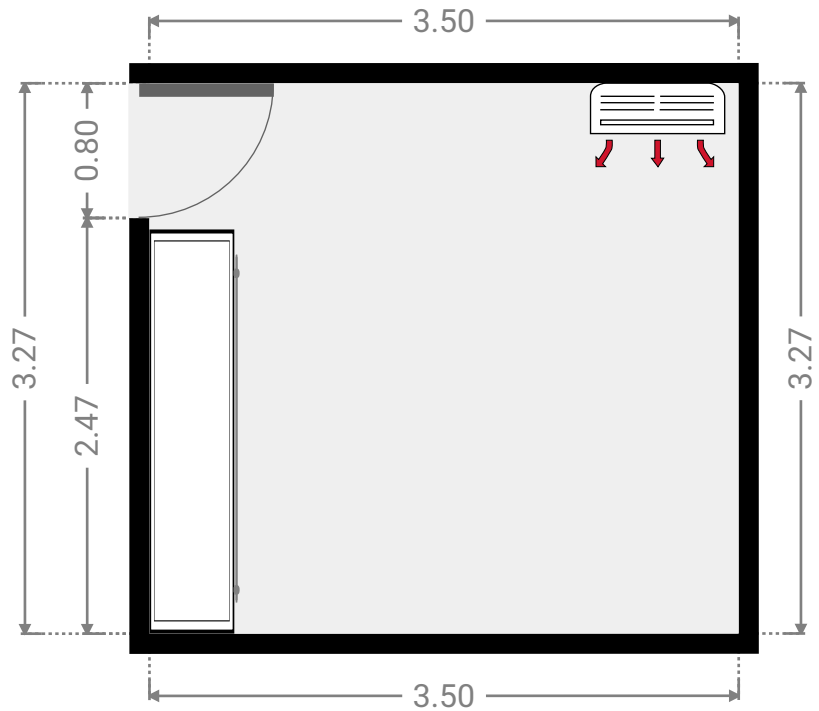
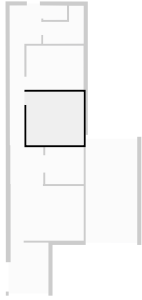

▼ **Bedroom**
Ground Floor

WIDTH: 3.50 m • LENGTH: 2.70 m
AREA: 9.46 m² • PERIMETER: 12.41 m

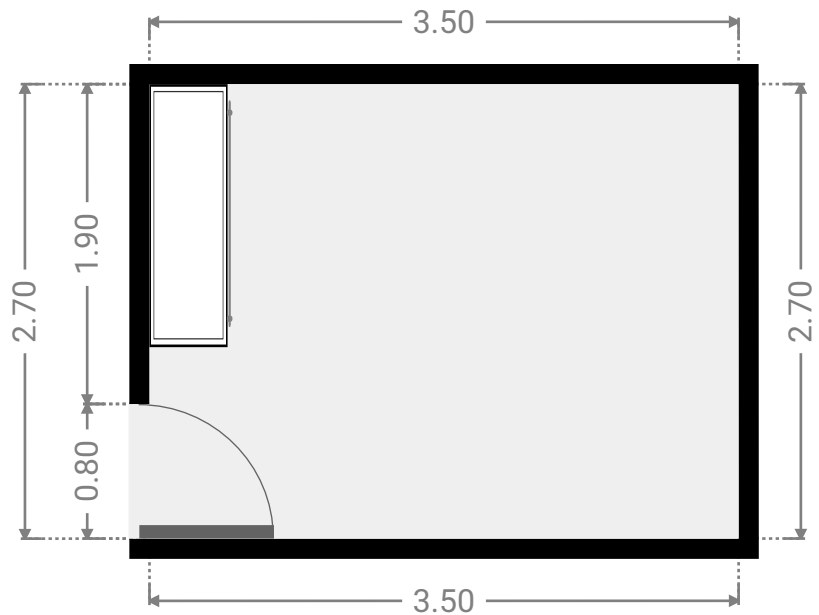
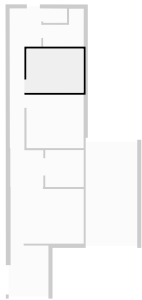

▼ **Bathroom**
Ground Floor

WIDTH: 2.50 m • LENGTH: 2.32 m
AREA: 4.22 m² • PERIMETER: 9.63 m

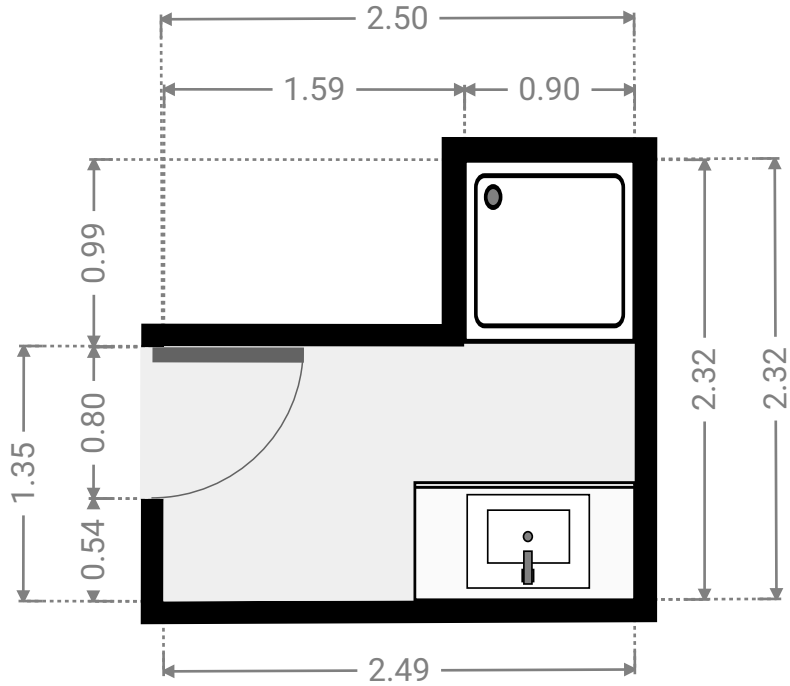
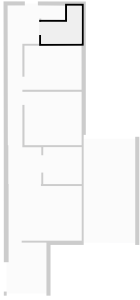

▼ **Toilet**
Ground Floor

WIDTH: 1.46 m • LENGTH: 0.89 m
AREA: 1.28 m² • PERIMETER: 4.67 m

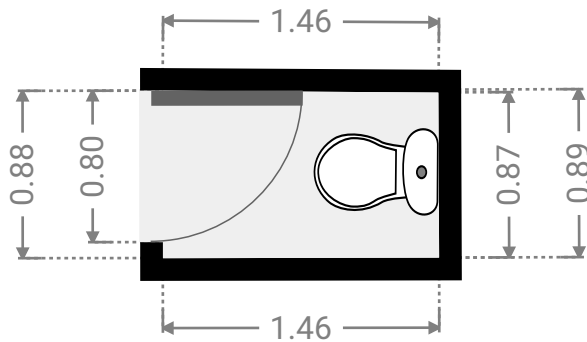
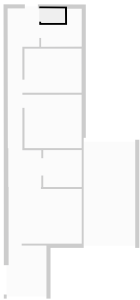

FLOORS: 1

▼ **Carpport**
Ground Floor

WIDTH: 3.16 m • LENGTH: 6.13 m
AREA: 19.37 m² • PERIMETER: 18.58 m

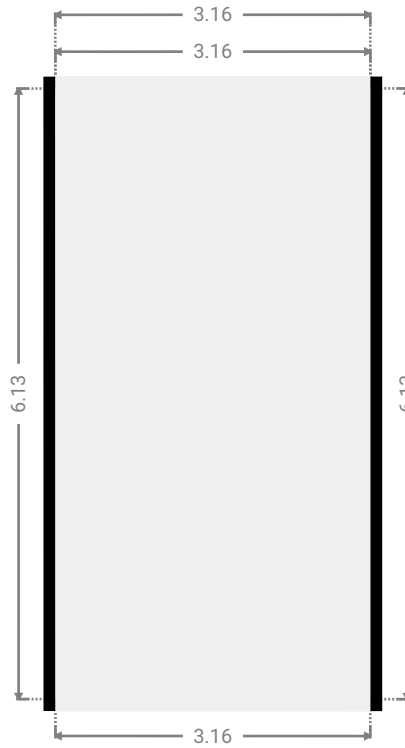
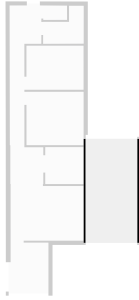

▼ **Other**
Ground Floor

WIDTH: 2.32 m • LENGTH: 3.00 m
AREA: 6.96 m² • PERIMETER: 10.64 m

