

Unit 9/35B Wentworth Terrace

SUBMITTED BY

Ray White Rockhampton Casey
stockers@cqoz.com

CREATED ON

2017-01-23

Floors

1

FLOORS: 1

▼ Ground Floor



THIS FLOORPLAN IS PROVIDED WITHOUT WARRANTY OF ANY KIND. SENSOPIA DISCLAIMS ANY WARRANTY INCLUDING, WITHOUT LIMITATION, SATISFACTORY QUALITY OR ACCURACY OF DIMENSIONS.

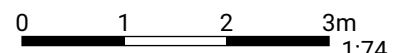

FLOORS: 1

▼ Living Room
Ground Floor

WIDTH: 5.18 m • LENGTH: 7.53 m
AREA: 27.31 m² • PERIMETER: 25.42 m

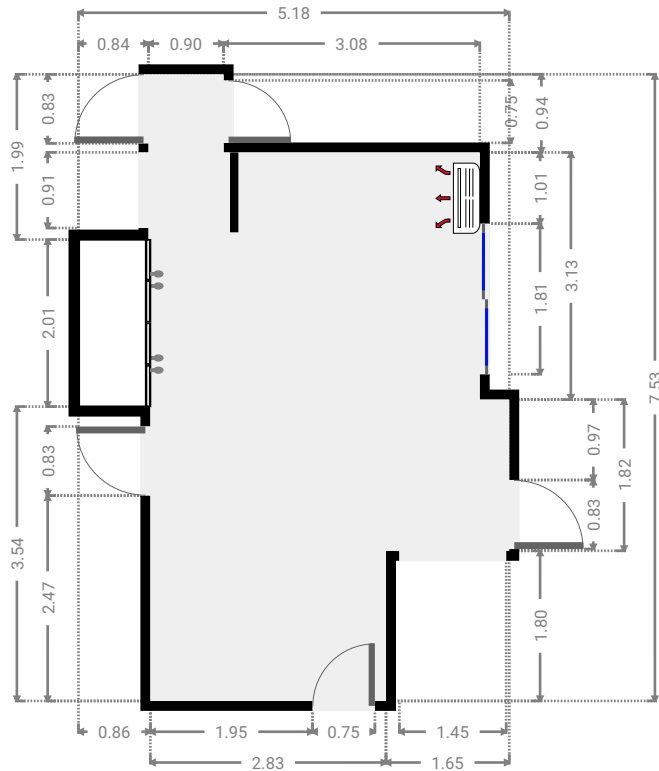
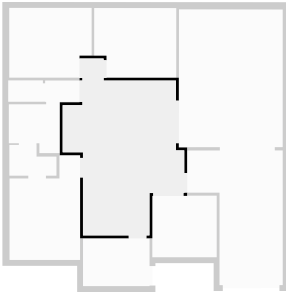

▼ Master Bedroom
Ground Floor

WIDTH: 3.00 m • LENGTH: 4.44 m
AREA: 11.26 m² • PERIMETER: 14.89 m

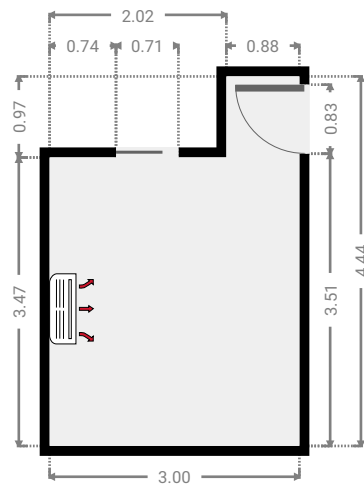
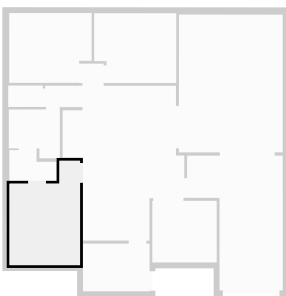

FLOORS: 1

▼ **WIR**
Ground Floor

WIDTH: 2.00 m • LENGTH: 1.31 m
AREA: 2.20 m² • PERIMETER: 6.63 m

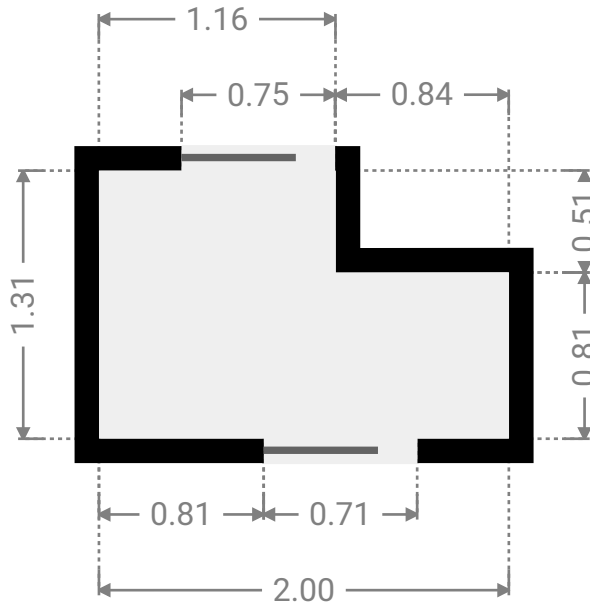
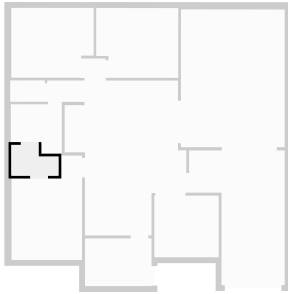

▼ **Bathroom**
Ground Floor

WIDTH: 2.17 m • LENGTH: 2.08 m
AREA: 3.96 m² • PERIMETER: 8.50 m

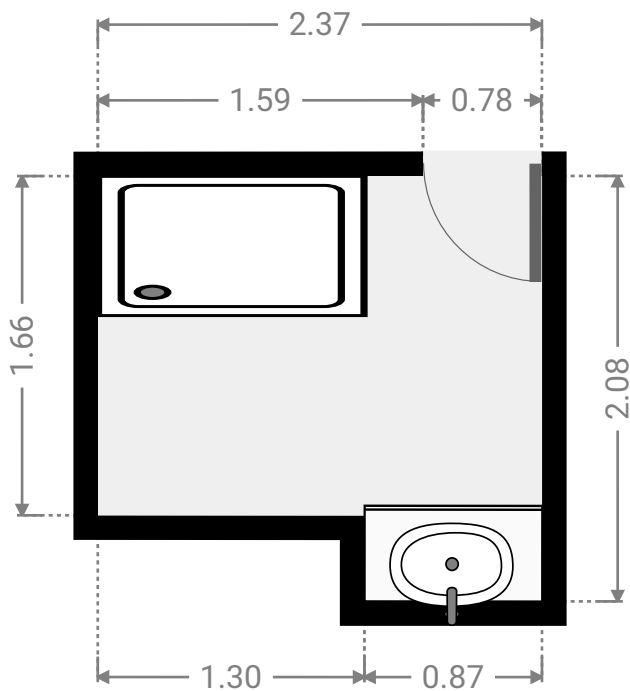
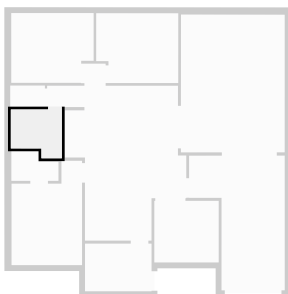

FLOORS: 1

▼ **Hall**
Ground Floor

WIDTH: 1.49 m • LENGTH: 0.91 m
AREA: 1.35 m² • PERIMETER: 4.79 m

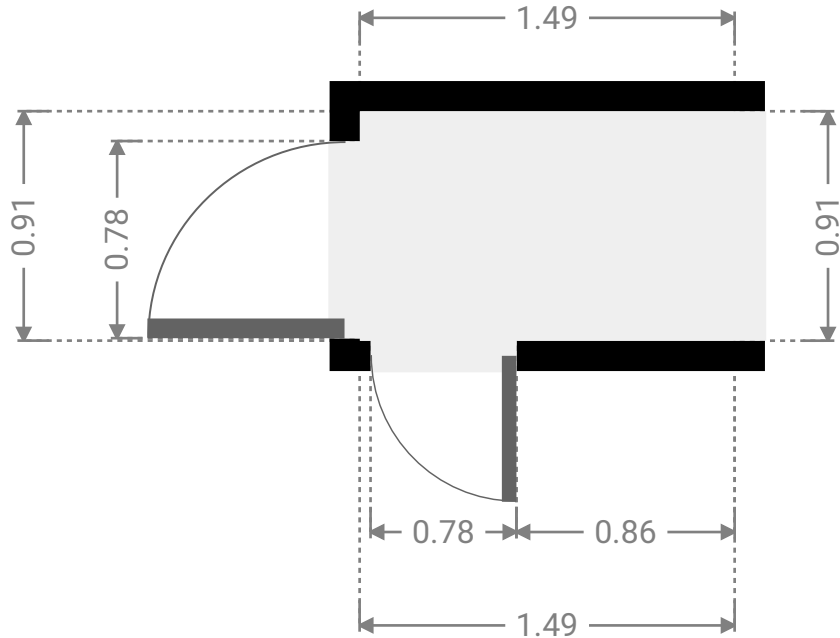
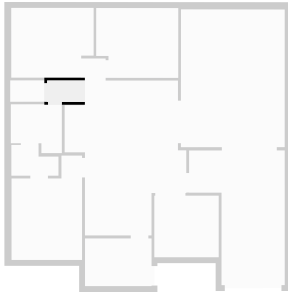

▼ **Toilet**
Ground Floor

WIDTH: 1.47 m • LENGTH: 0.91 m
AREA: 1.34 m² • PERIMETER: 4.77 m

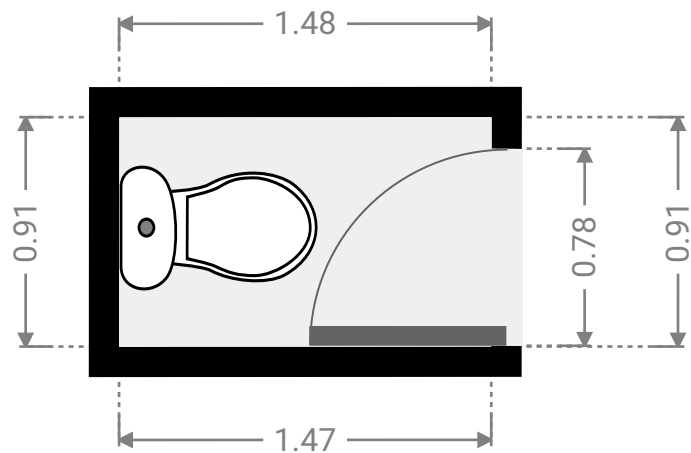
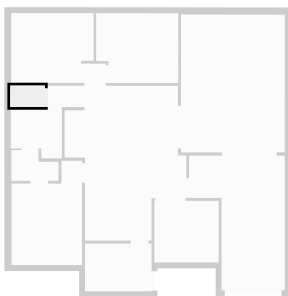

FLOORS: 1

▼ **Bedroom**
Ground Floor

WIDTH: 3.51 m • LENGTH: 2.97 m
AREA: 9.91 m² • PERIMETER: 12.95 m

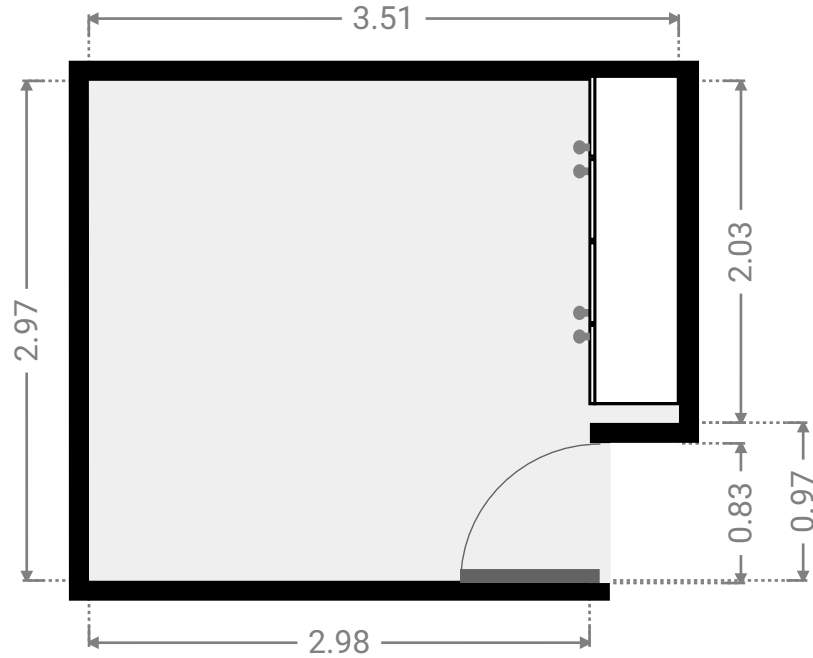
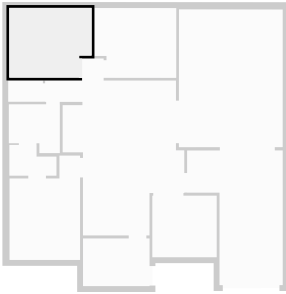

▼ **Bedroom**
Ground Floor

WIDTH: 3.49 m • LENGTH: 2.97 m
AREA: 9.89 m² • PERIMETER: 12.93 m

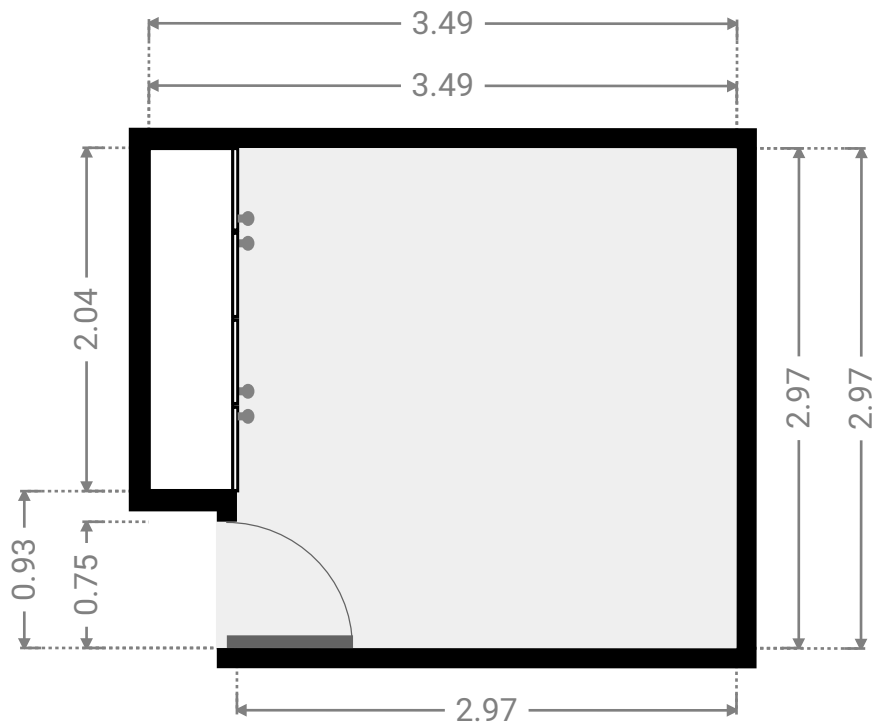
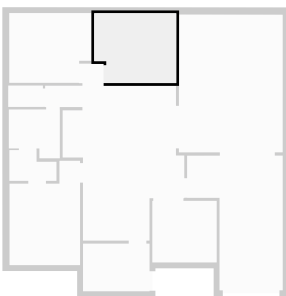

FLOORS: 1

▼ Kitchen
Ground Floor

WIDTH: 2.74 m • LENGTH: 2.62 m
AREA: 7.18 m² • PERIMETER: 10.72 m

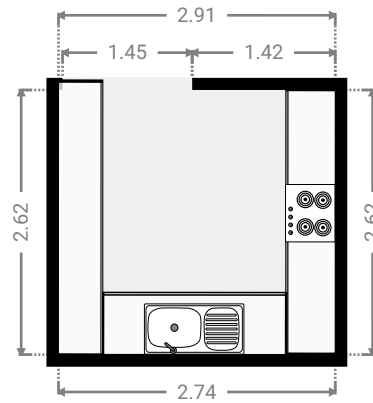
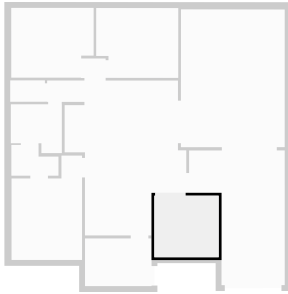

▼ Garage
Ground Floor

WIDTH: 4.07 m • LENGTH: 5.73 m
AREA: 17.89 m² • PERIMETER: 19.60 m

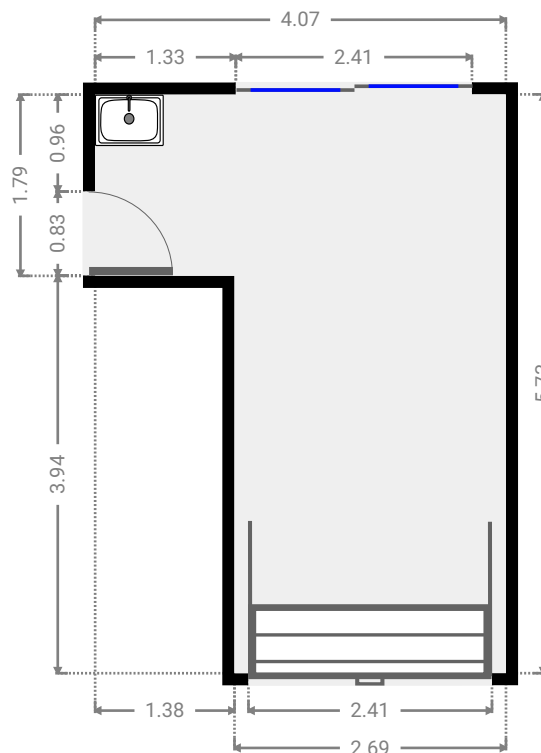
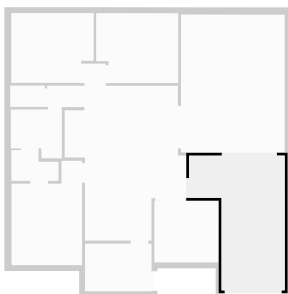

FLOORS: 1

▼ **Entertainment Area**
Ground Floor

WIDTH: 4.42 m • LENGTH: 5.86 m
AREA: 25.89 m² • PERIMETER: 20.56 m

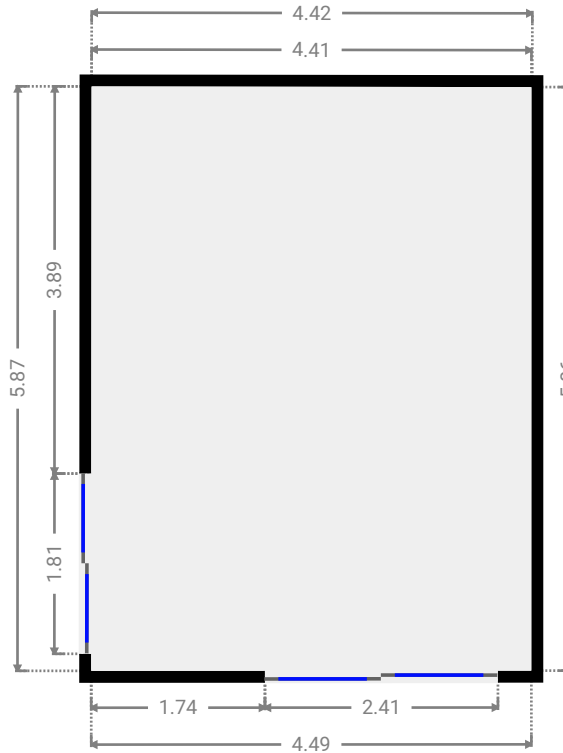
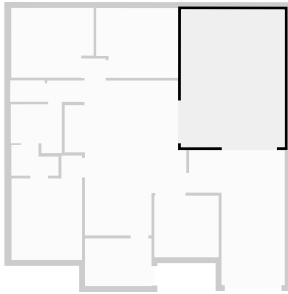

▼ **Entry**
Ground Floor

WIDTH: 2.83 m • LENGTH: 2.03 m
AREA: 5.74 m² • PERIMETER: 9.72 m

