

Unit 7-190 Lion Creek Road

SUBMITTED BY
Ray White Rockhampton Casey
stockers@cqoz.com

CREATED ON
2017-12-15

Floors
1

▼ Ground Floor



FLOORS: 1

▼ Living/Dining/Kitchen
Ground Floor

WIDTH: 9.56 m • LENGTH: 7.88 m
AREA: 53.11 m² • PERIMETER: 34.84 m

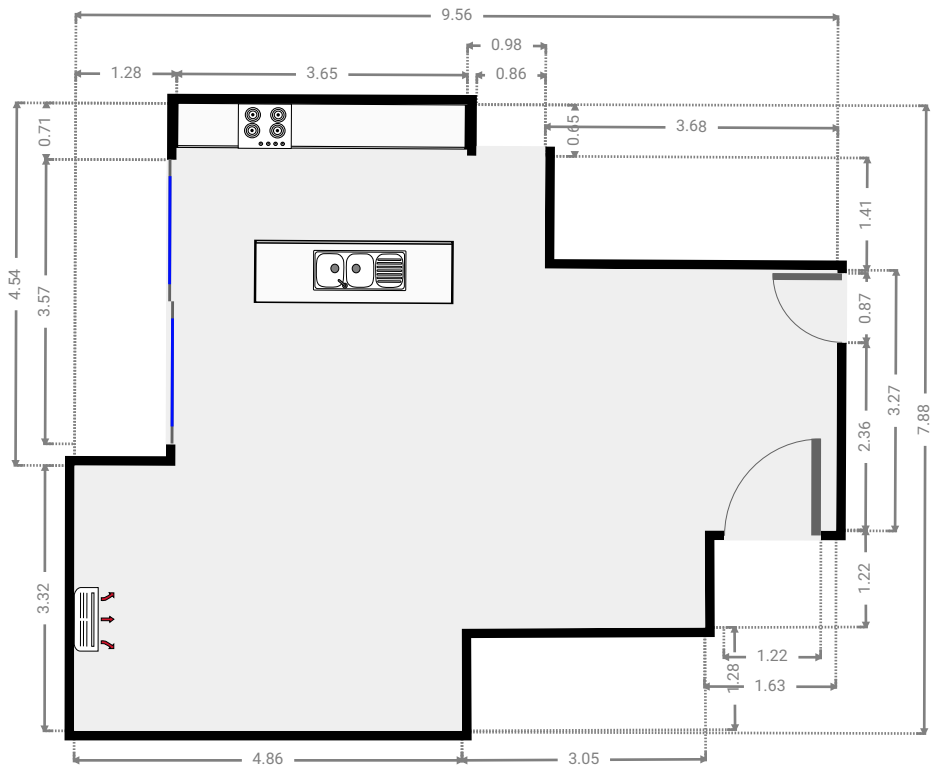
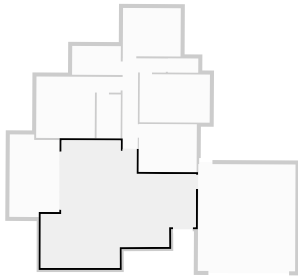

▼ Hall
Ground Floor

WIDTH: 2.66 m • LENGTH: 5.57 m
AREA: 6.79 m² • PERIMETER: 16.46 m

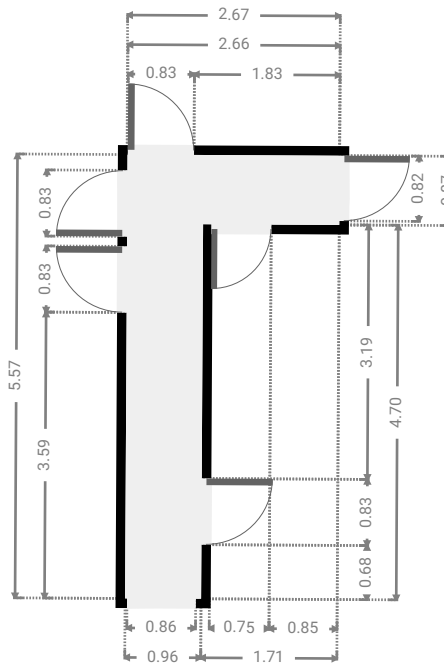
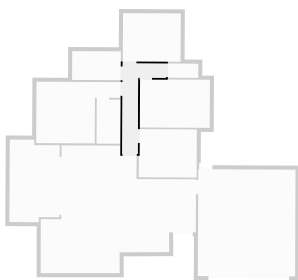

FLOORS: 1

▼ **Bedroom**
Ground Floor

WIDTH: 3.56 m • LENGTH: 2.97 m
AREA: 10.57 m² • PERIMETER: 13.06 m

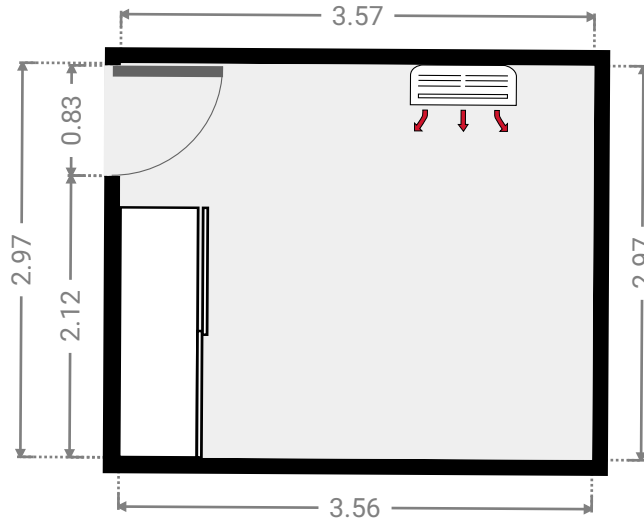
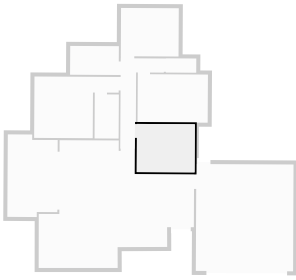

▼ **Primary Bedroom**
Ground Floor

WIDTH: 5.19 m • LENGTH: 3.78 m
AREA: 15.19 m² • PERIMETER: 17.95 m

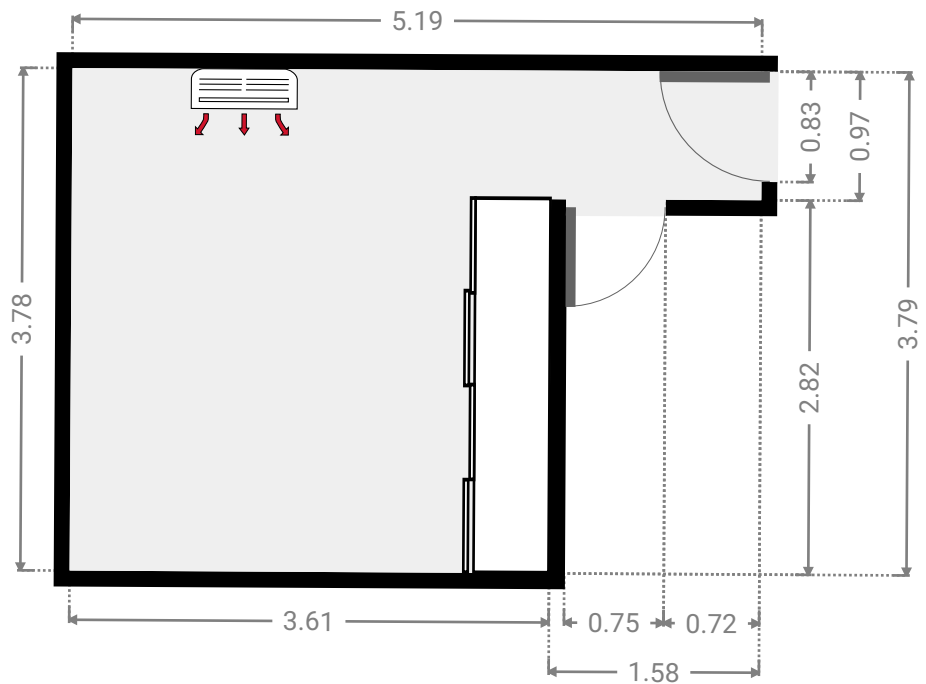
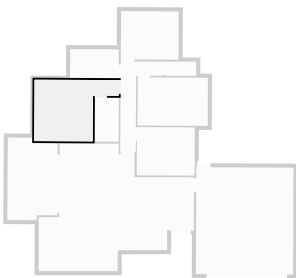

FLOORS: 1

▼ **Ensuite**
Ground Floor

WIDTH: 1.48 m • LENGTH: 2.72 m
AREA: 4.03 m² • PERIMETER: 8.40 m

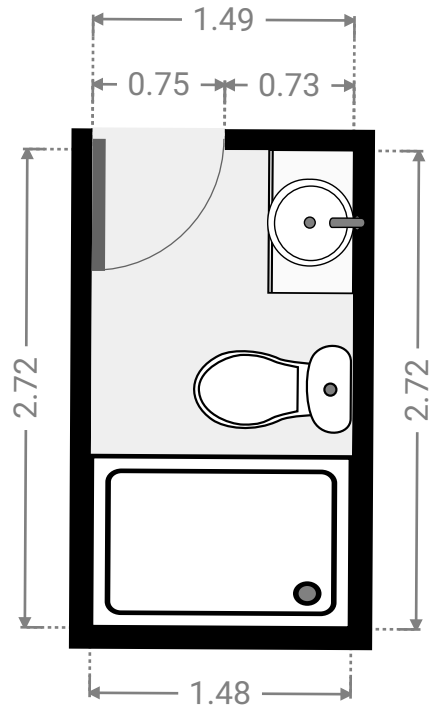
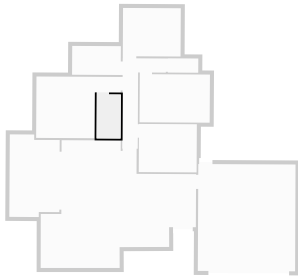

▼ **Bathroom**
Ground Floor

WIDTH: 3.00 m • LENGTH: 1.78 m
AREA: 5.32 m² • PERIMETER: 9.54 m

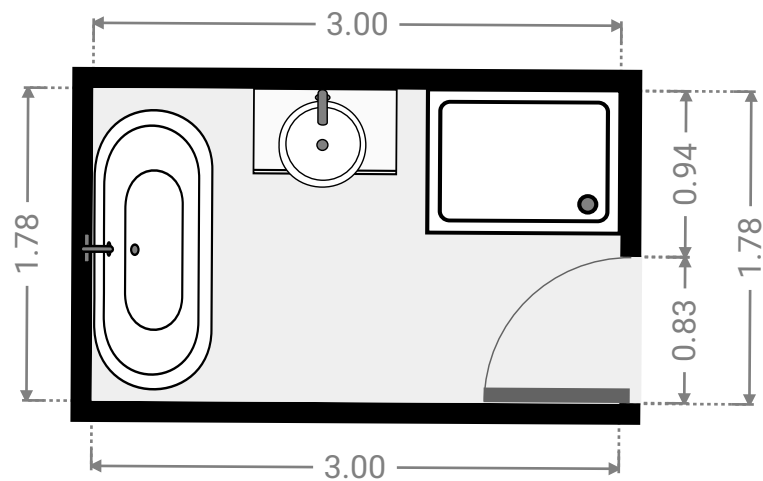
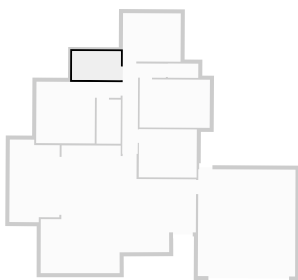

FLOORS: 1

▼ **Bedroom**
Ground Floor

WIDTH: 3.56 m • LENGTH: 2.98 m
AREA: 10.58 m² • PERIMETER: 13.06 m

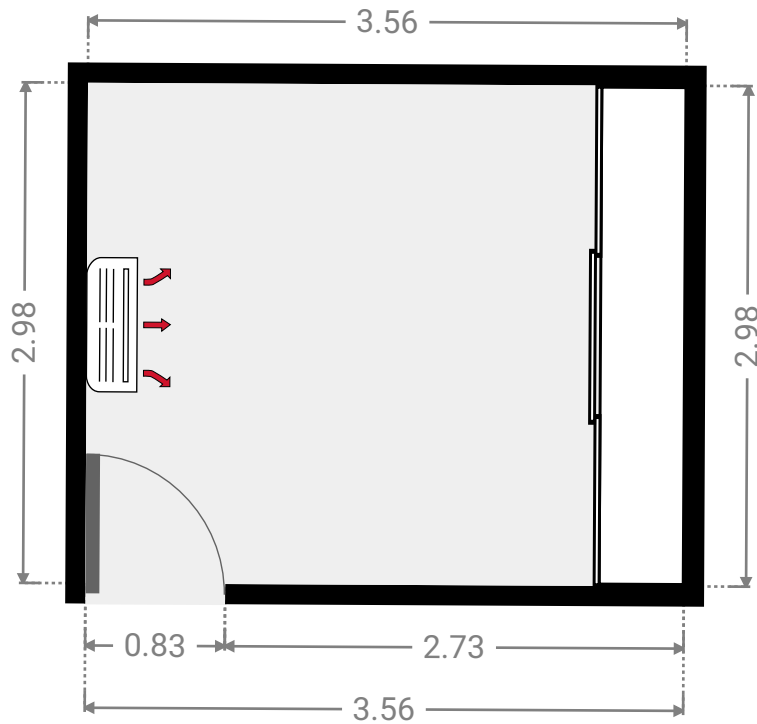
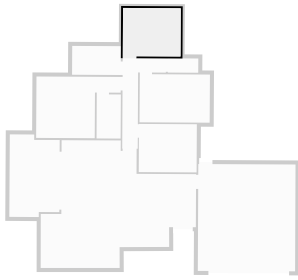

▼ **Toilet**
Ground Floor

WIDTH: 1.87 m • LENGTH: 0.88 m
AREA: 1.64 m² • PERIMETER: 5.50 m

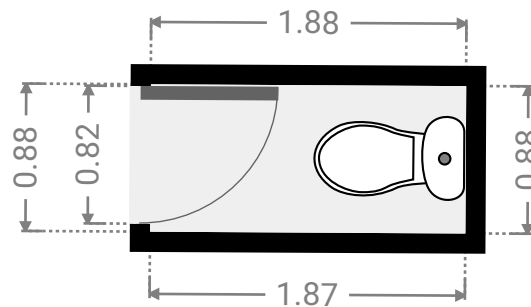
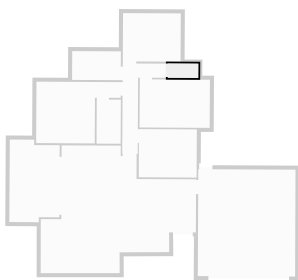

FLOORS: 1

▼ **Bedroom**
Ground Floor

WIDTH: 4.32 m • LENGTH: 2.97 m
AREA: 12.81 m² • PERIMETER: 14.57 m

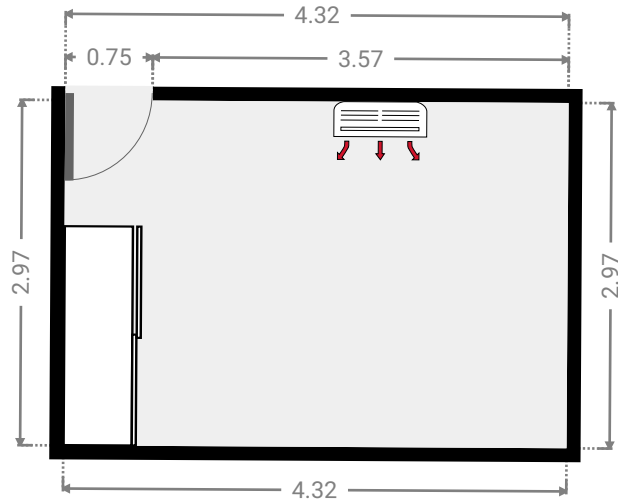
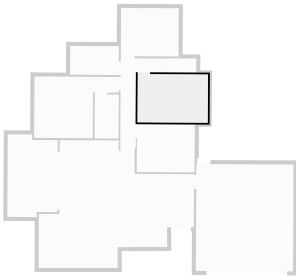

▼ **Deck**
Ground Floor

WIDTH: 3.08 m • LENGTH: 5.08 m
AREA: 14.72 m² • PERIMETER: 16.32 m

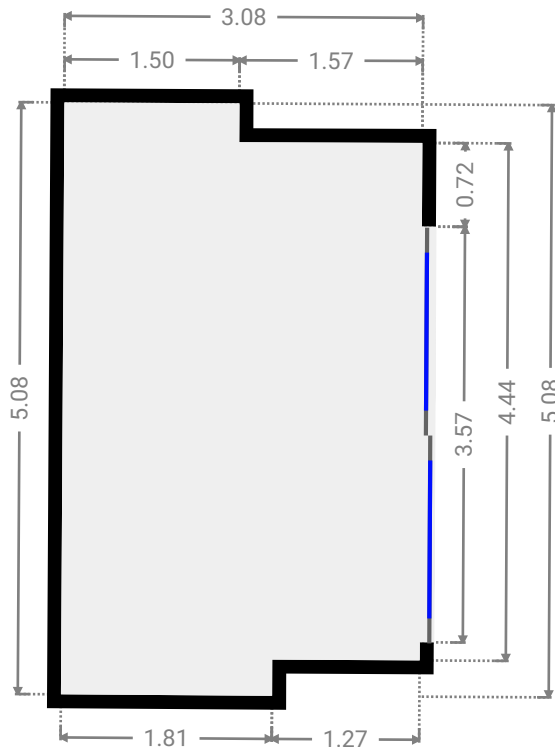
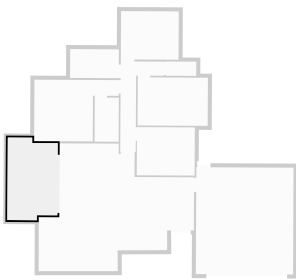

FLOORS: 1

▼ **Garage**
Ground Floor

WIDTH: 6.00 m • LENGTH: 6.58 m
AREA: 39.45 m² • PERIMETER: 25.15 m

