

# Unit 6 Parkside Place

**SUBMITTED BY**  
Ray White Rockhampton Casey  
stockers@cqoz.com

---

**CREATED ON**  
2022-05-30

---

**Floors**  
1

---

## ▼ Ground Floor

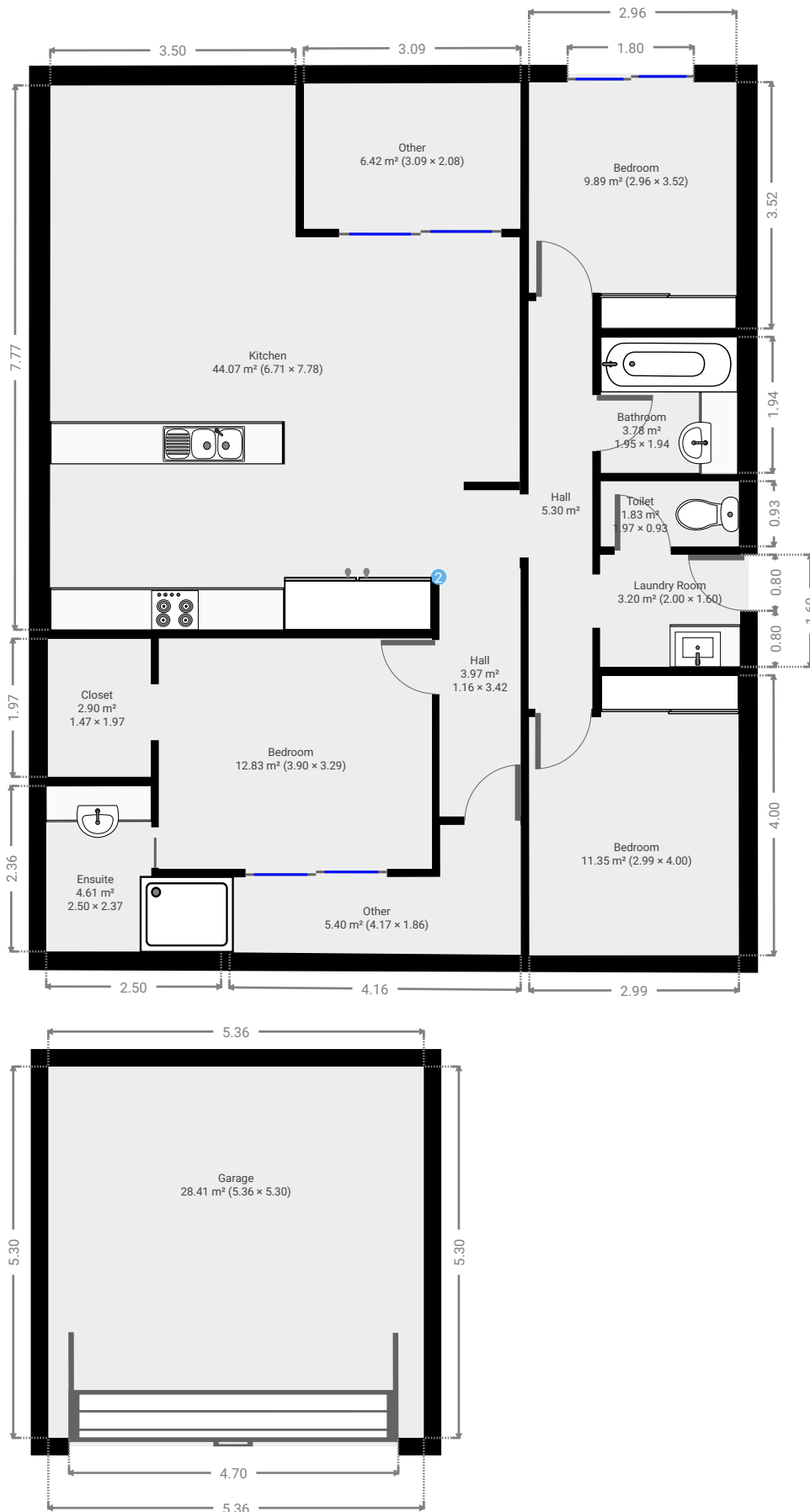

FLOORS: 1

▼ **Bathroom**  
Ground Floor

WIDTH: 1.95 m • LENGTH: 1.94 m  
AREA: 3.78 m<sup>2</sup> • PERIMETER: 7.78 m

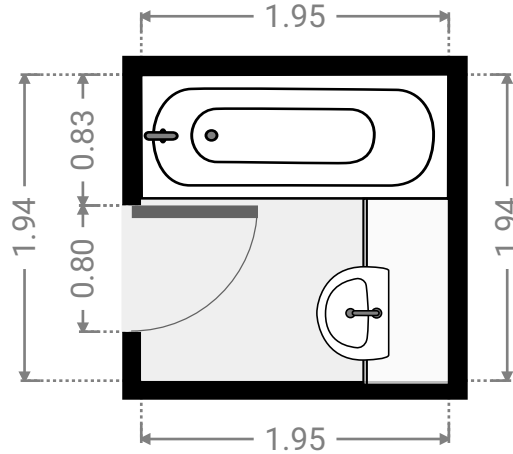
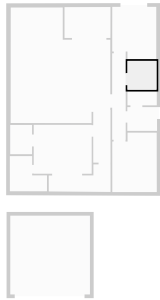

▼ **Bedroom**  
Ground Floor

WIDTH: 3.90 m • LENGTH: 3.29 m  
AREA: 12.83 m<sup>2</sup> • PERIMETER: 14.38 m

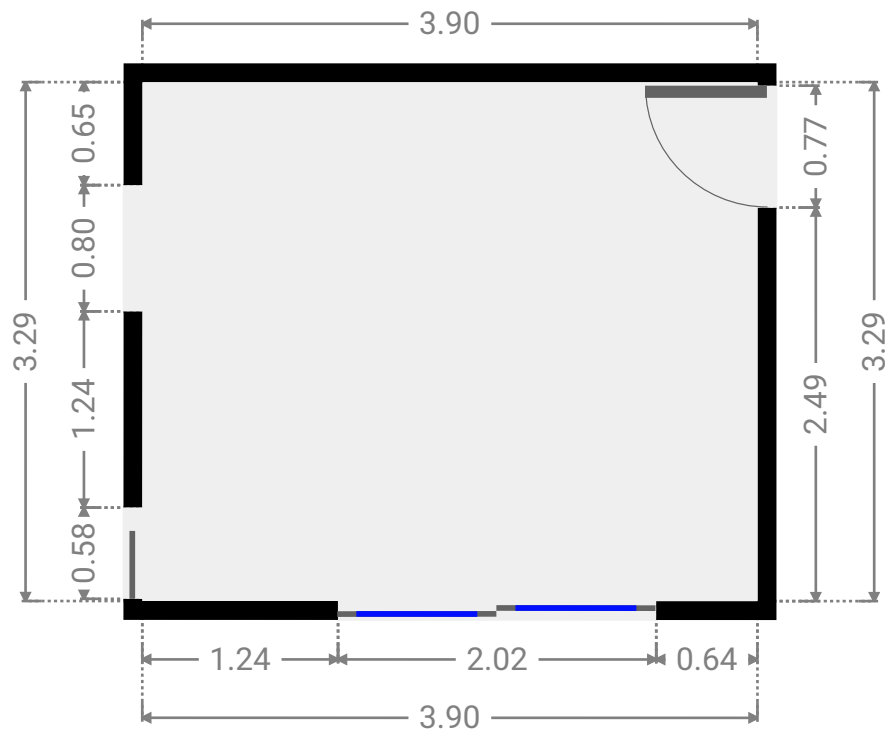
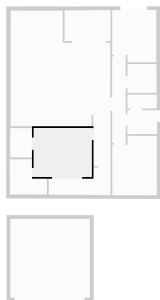

FLOORS: 1

▼ Closet  
Ground Floor

WIDTH: 1.47 m • LENGTH: 1.97 m  
AREA: 2.90 m<sup>2</sup> • PERIMETER: 6.88 m

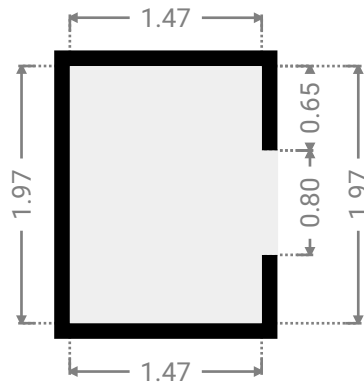
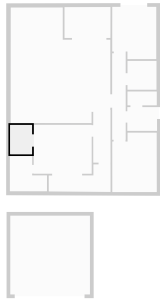

▼ Bedroom  
Ground Floor

WIDTH: 2.99 m • LENGTH: 4.00 m  
AREA: 11.35 m<sup>2</sup> • PERIMETER: 13.98 m

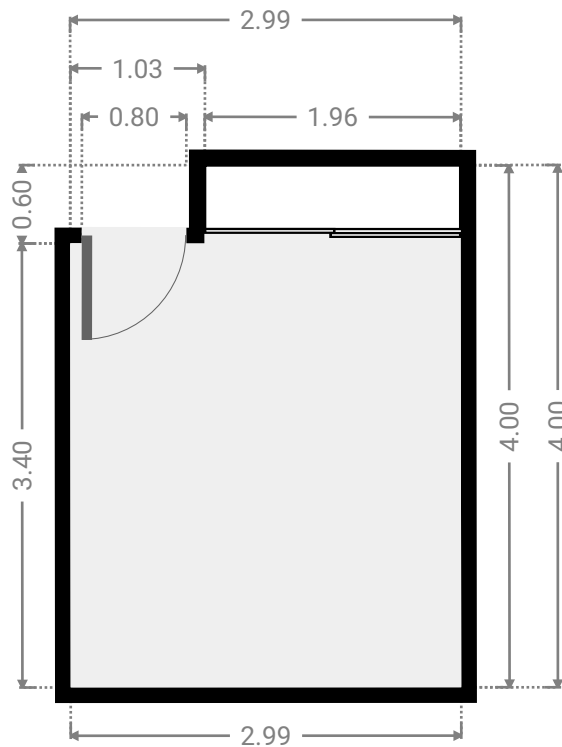
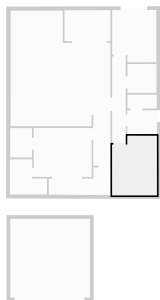

FLOORS: 1

▼ **Bedroom**  
Ground Floor

WIDTH: 2.96 m • LENGTH: 3.52 m  
AREA: 9.89 m<sup>2</sup> • PERIMETER: 12.95 m

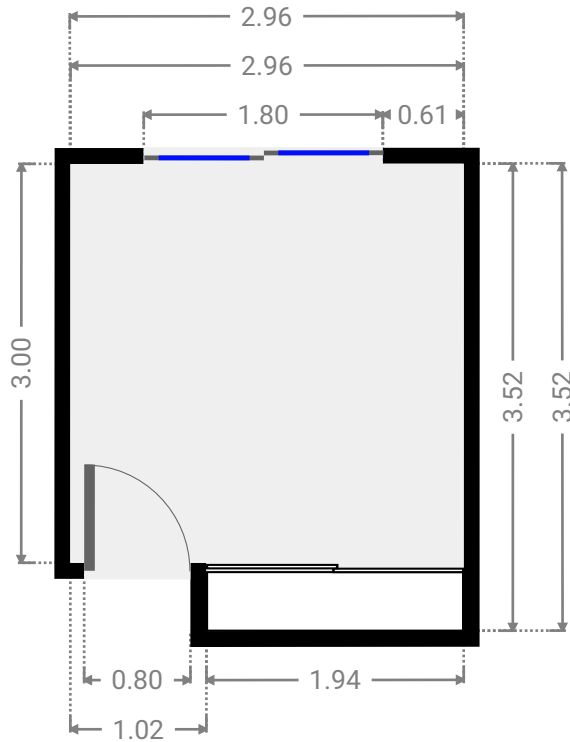
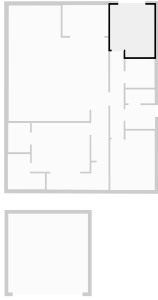

▼ **Ensuite**  
Ground Floor

WIDTH: 2.50 m • LENGTH: 2.37 m  
AREA: 4.61 m<sup>2</sup> • PERIMETER: 9.73 m

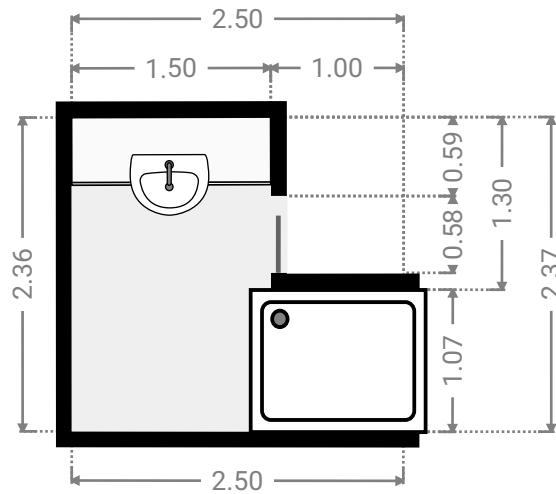
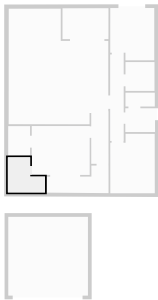

FLOORS: 1

▼ **Garage**  
Ground Floor

WIDTH: 5.36 m • LENGTH: 5.30 m  
AREA: 28.41 m<sup>2</sup> • PERIMETER: 21.32 m

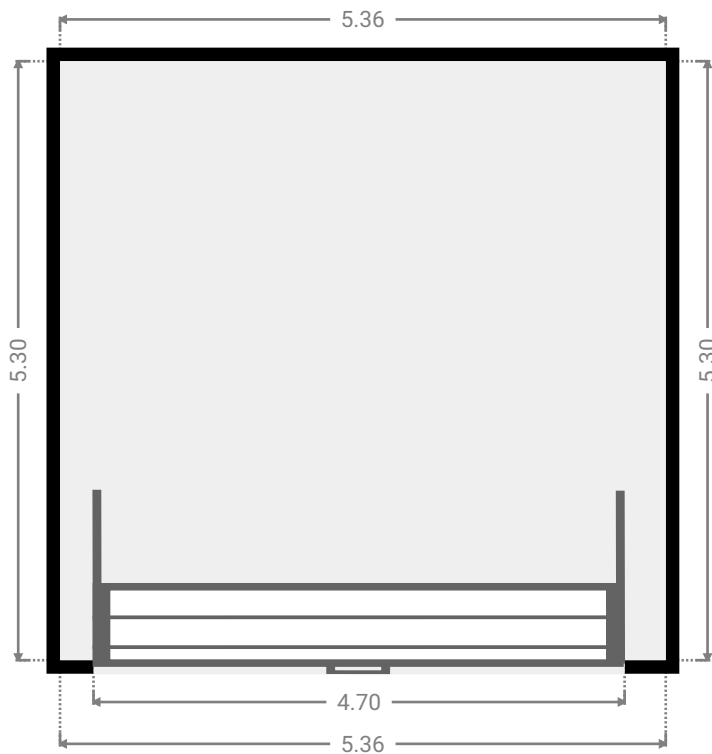
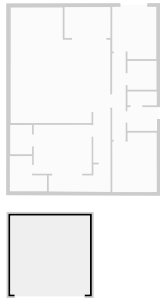

▼ **Hall**  
Ground Floor

WIDTH: 1.16 m • LENGTH: 3.42 m  
AREA: 3.97 m<sup>2</sup> • PERIMETER: 9.16 m

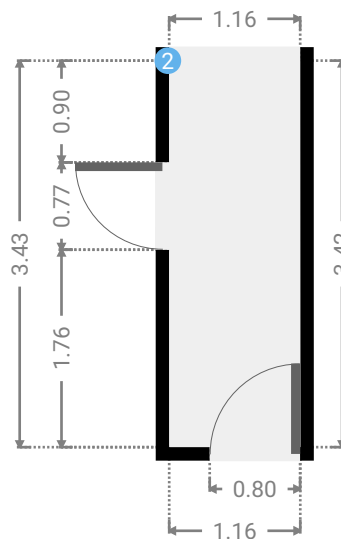
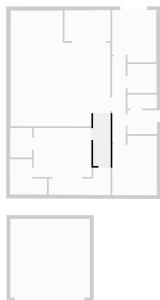

## ▼ Hall/Ground Floor

---

### 2 OPENING

Height  
0.00 m



FLOORS: 1

▼ **Hall**  
Ground Floor

WIDTH: 0.91 m • LENGTH: 5.82 m  
AREA: 5.30 m<sup>2</sup> • PERIMETER: 13.46 m

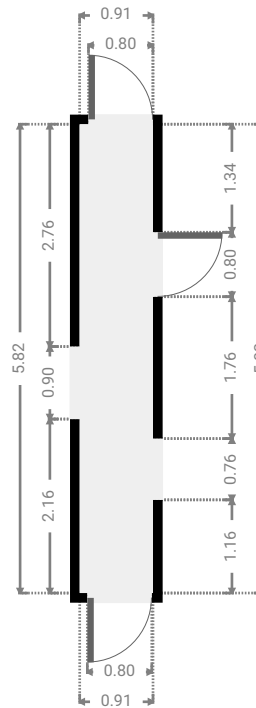
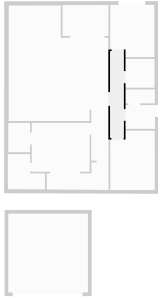

▼ **Kitchen**  
Ground Floor

WIDTH: 6.71 m • LENGTH: 7.78 m  
AREA: 44.07 m<sup>2</sup> • PERIMETER: 28.96 m

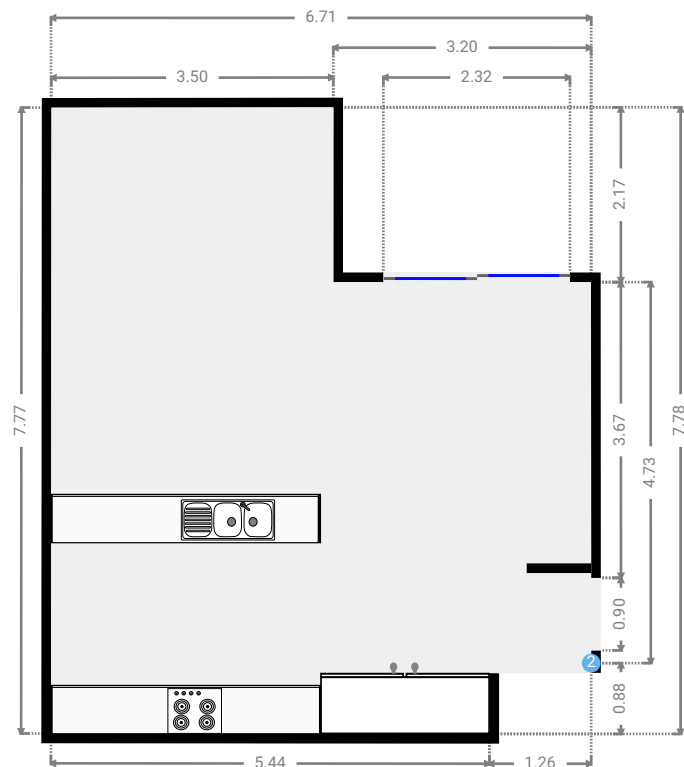
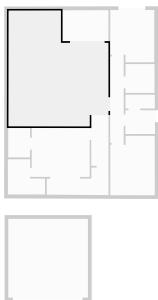



FLOORS: 1

▼ Laundry Room  
Ground Floor

WIDTH: 2.00 m • LENGTH: 1.60 m  
AREA: 3.20 m<sup>2</sup> • PERIMETER: 7.20 m

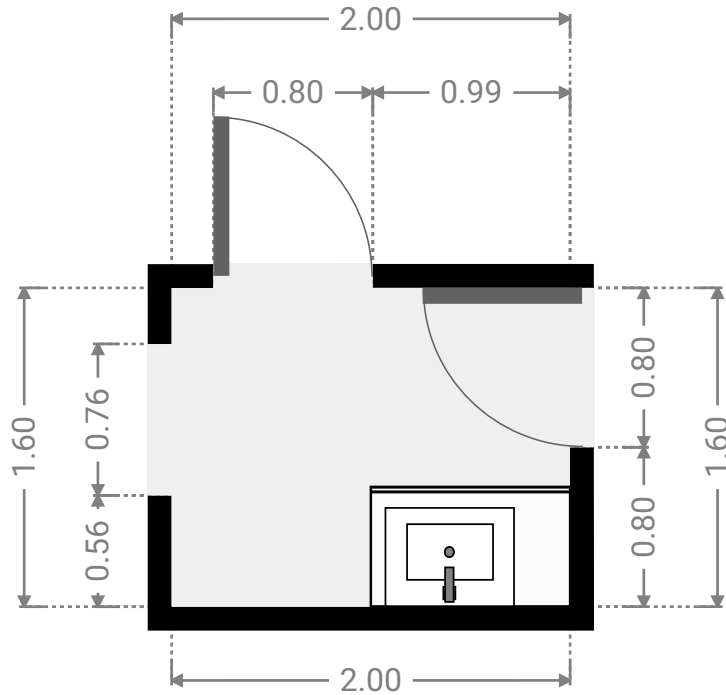
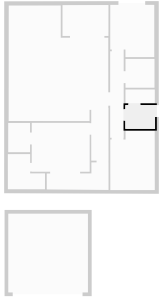

▼ Other  
Ground Floor

WIDTH: 3.09 m • LENGTH: 2.08 m  
AREA: 6.42 m<sup>2</sup> • PERIMETER: 10.34 m

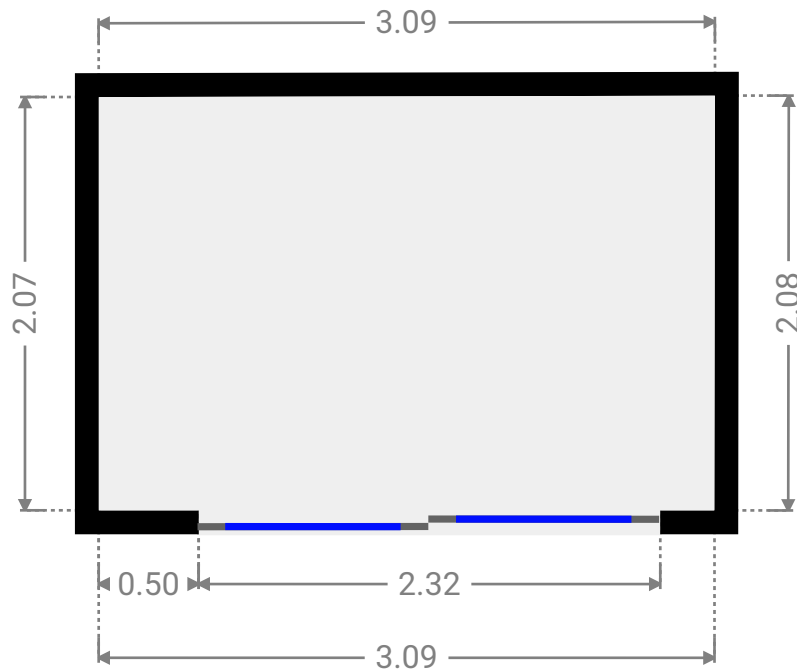
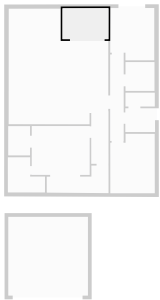

FLOORS: 1

▼ Other  
Ground Floor

WIDTH: 4.17 m • LENGTH: 1.86 m  
AREA: 5.40 m<sup>2</sup> • PERIMETER: 11.98 m

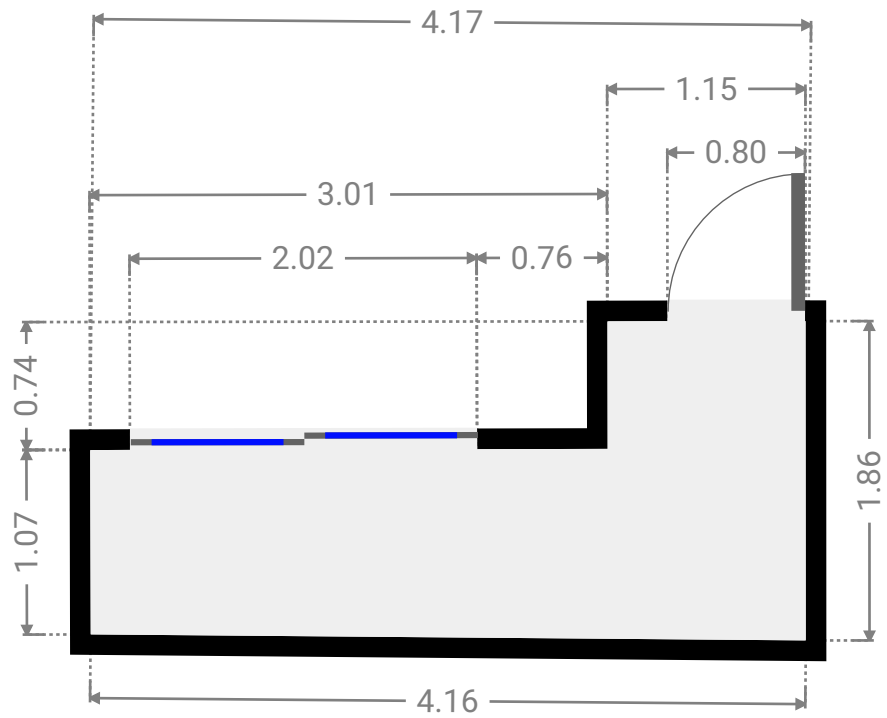
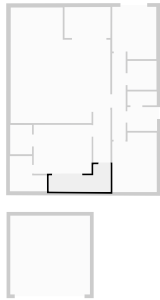

▼ Toilet  
Ground Floor

WIDTH: 1.97 m • LENGTH: 0.93 m  
AREA: 1.83 m<sup>2</sup> • PERIMETER: 5.80 m

