

# Unit 4/15 Parkside Place

Created on  
2021-06-16

Floors  
2

▼ Ground Floor

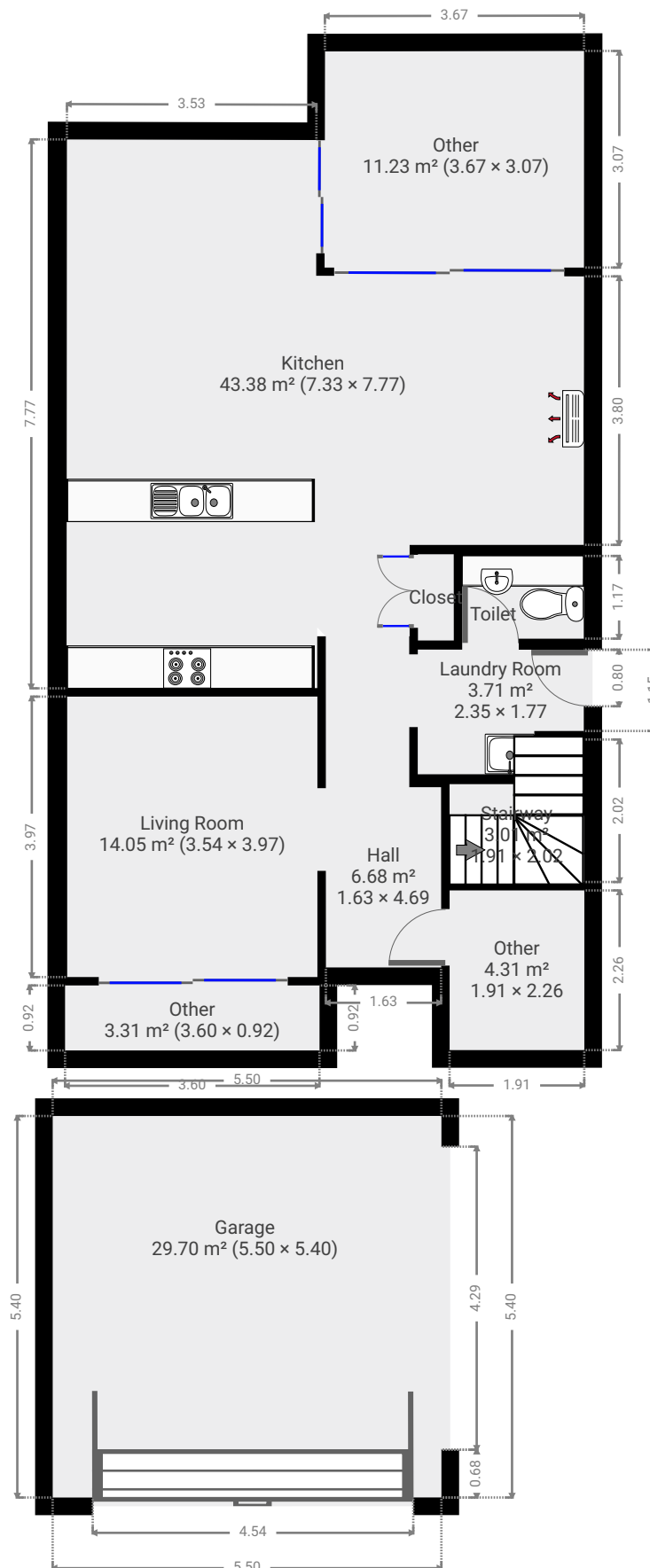

▼ **Hall**  
Ground Floor

WIDTH: 1.63 m • LENGTH: 4.69 m  
AREA: 6.68 m<sup>2</sup> • PERIMETER: 12.64 m

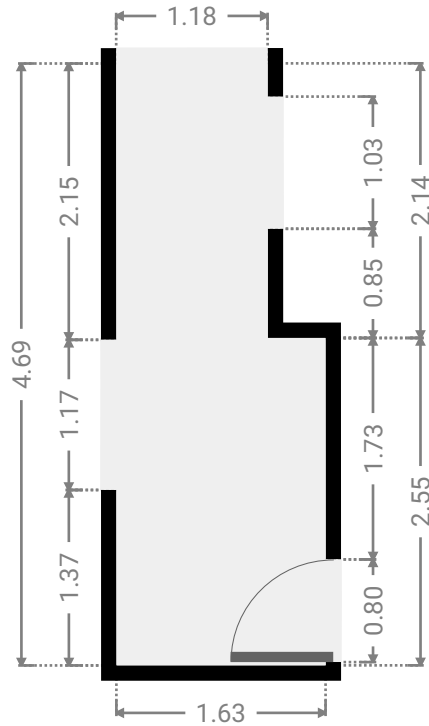
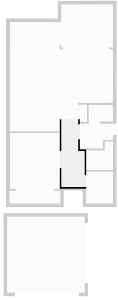

▼ **Laundry Room**  
Ground Floor

WIDTH: 2.35 m • LENGTH: 1.77 m  
AREA: 3.71 m<sup>2</sup> • PERIMETER: 8.23 m

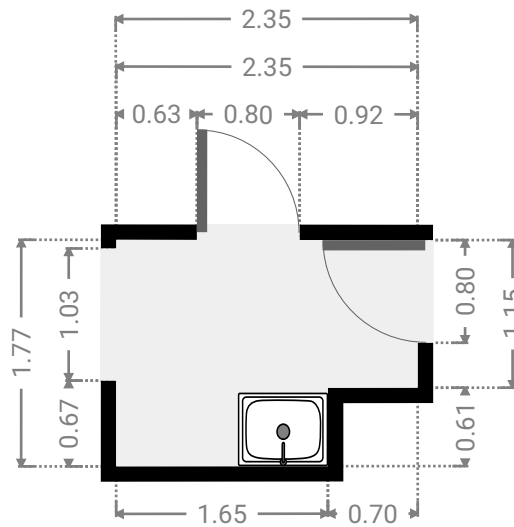
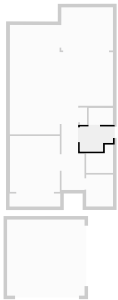

▼ **Toilet**  
Ground Floor

WIDTH: 1.72 m • LENGTH: 1.17 m  
AREA: 2.01 m<sup>2</sup> • PERIMETER: 5.78 m

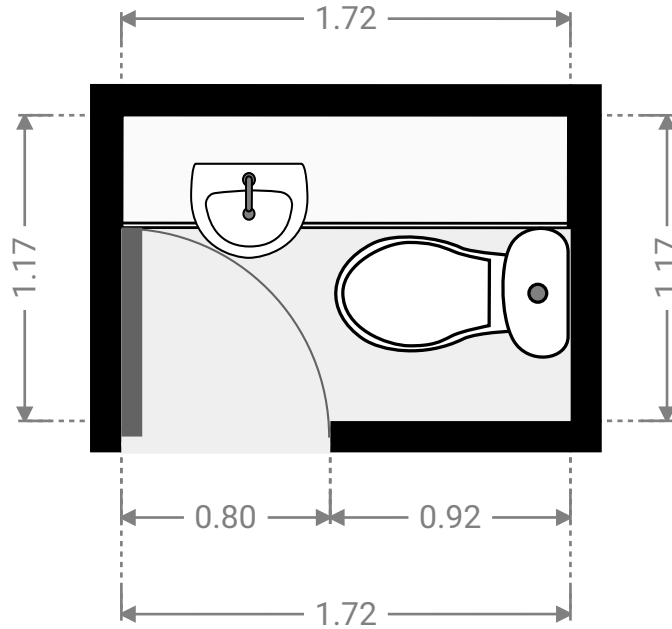
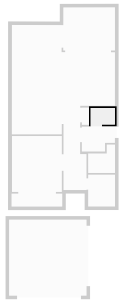

▼ **Closet**  
Ground Floor

WIDTH: 0.51 m • LENGTH: 1.22 m  
AREA: 0.62 m<sup>2</sup> • PERIMETER: 3.45 m

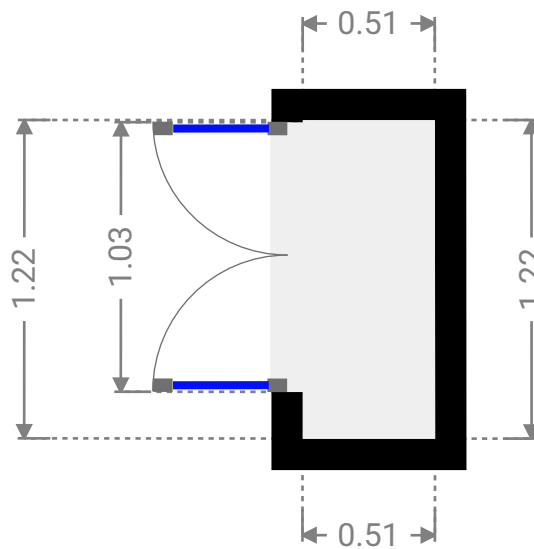
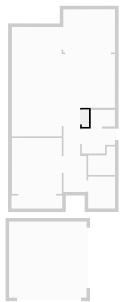

▼ Living Room  
Ground Floor

WIDTH: 3.54 m • LENGTH: 3.97 m  
AREA: 14.05 m<sup>2</sup> • PERIMETER: 15.02 m

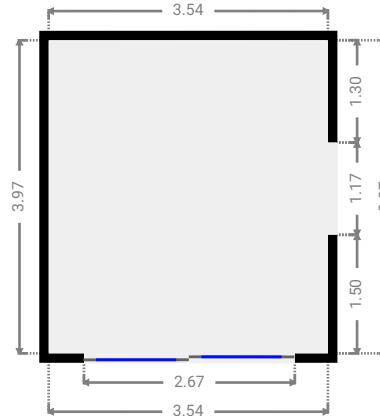
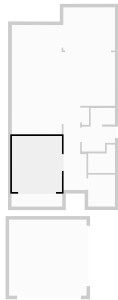

▼ Kitchen  
Ground Floor

WIDTH: 7.33 m • LENGTH: 7.77 m  
AREA: 43.38 m<sup>2</sup> • PERIMETER: 30.16 m

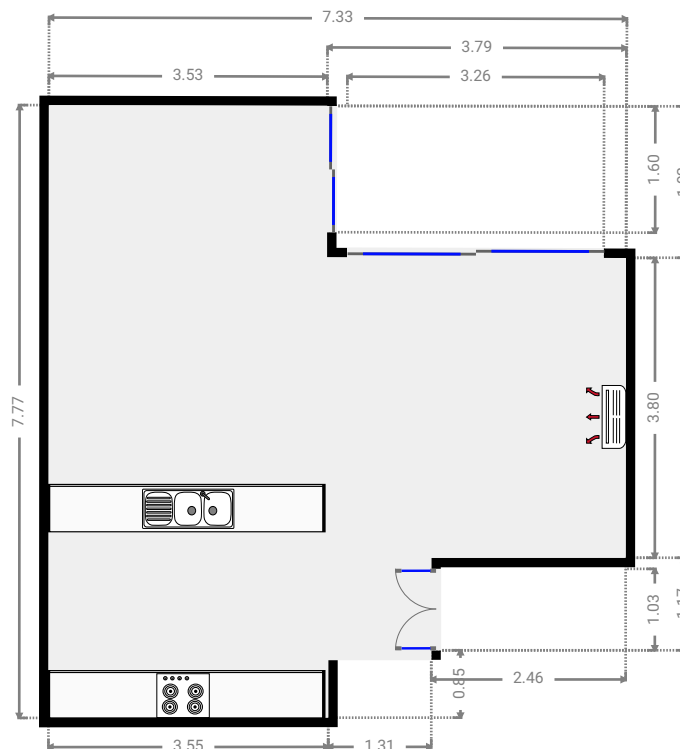
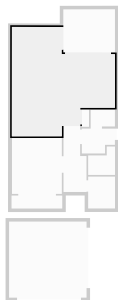

▼ Other  
Ground Floor

WIDTH: 3.67 m • LENGTH: 3.07 m  
AREA: 11.23 m<sup>2</sup> • PERIMETER: 13.46 m

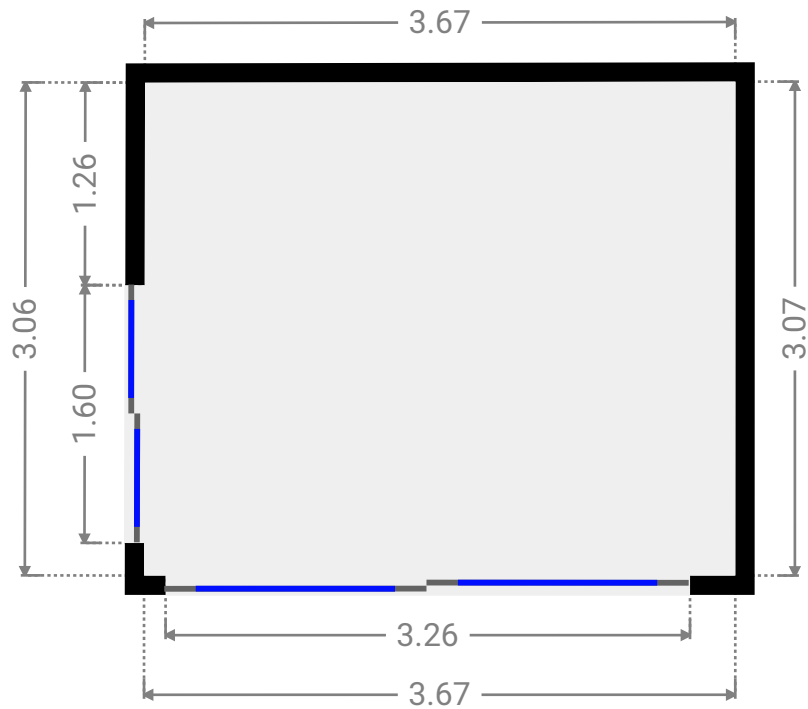

▼ Stairway  
Ground Floor

WIDTH: 1.91 m • LENGTH: 2.02 m  
AREA: 3.01 m<sup>2</sup> • PERIMETER: 7.84 m

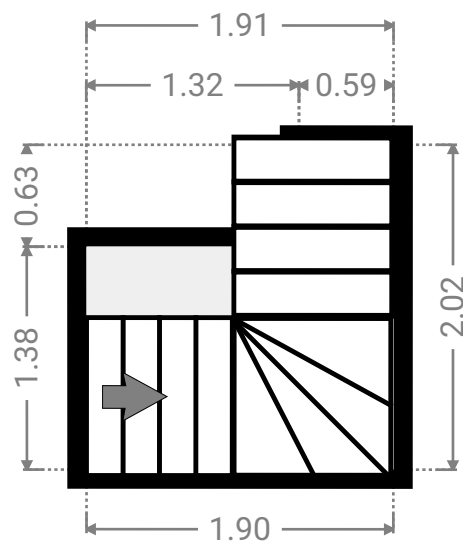
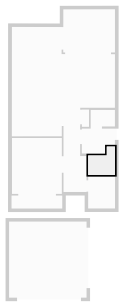

▼ Other  
Ground Floor

WIDTH: 1.91 m • LENGTH: 2.26 m  
AREA: 4.31 m<sup>2</sup> • PERIMETER: 8.33 m

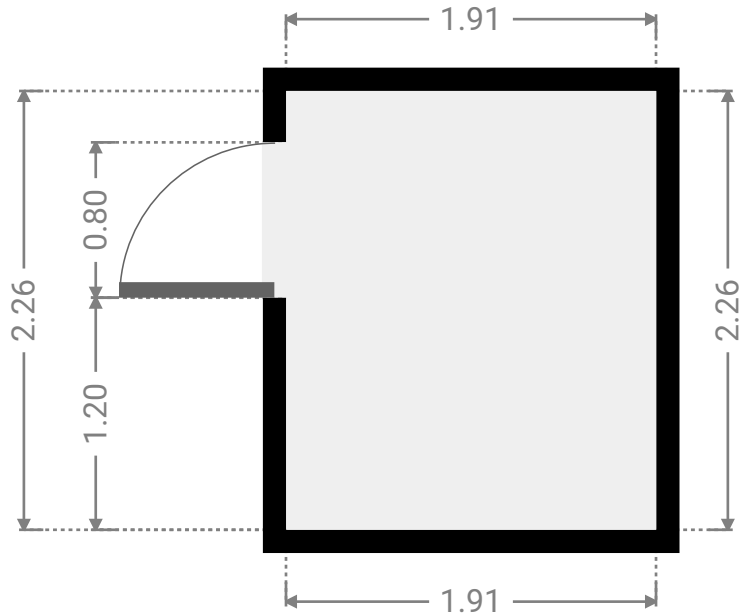
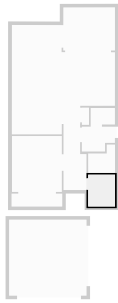

▼ Other  
Ground Floor

WIDTH: 3.60 m • LENGTH: 0.92 m  
AREA: 3.31 m<sup>2</sup> • PERIMETER: 9.04 m

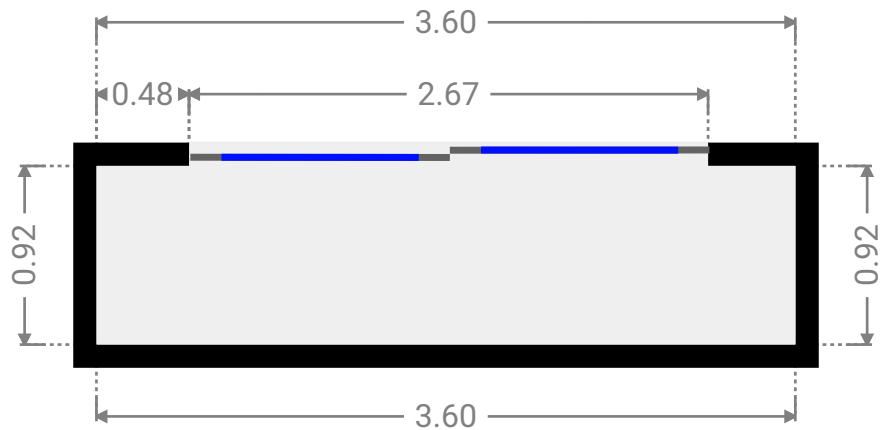
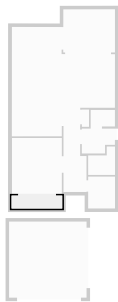

▼ **Garage**  
Ground Floor

WIDTH: 5.50 m • LENGTH: 5.40 m  
AREA: 29.70 m<sup>2</sup> • PERIMETER: 21.80 m

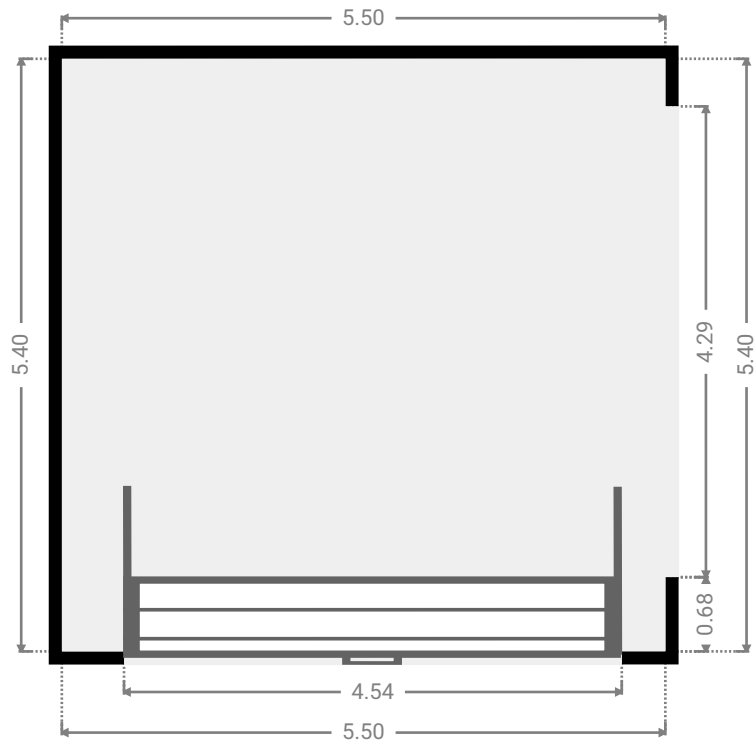



▼ 1st Floor

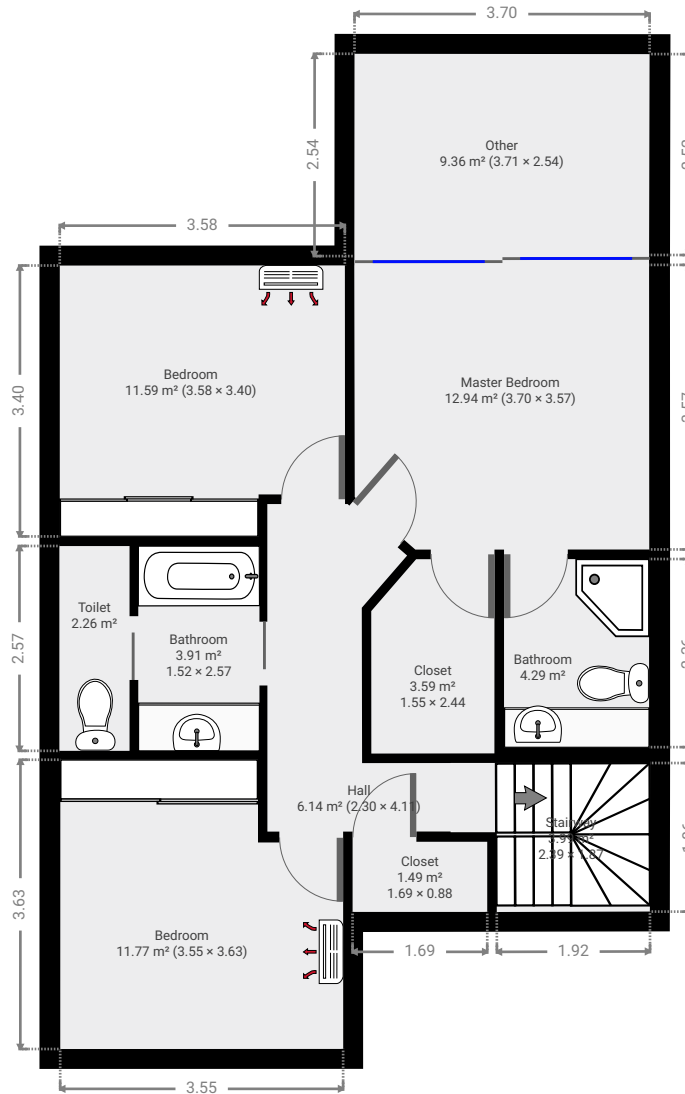

▼ **Hall**  
1st Floor

WIDTH: 2.30 m • LENGTH: 4.11 m  
AREA: 6.14 m<sup>2</sup> • PERIMETER: 13.19 m

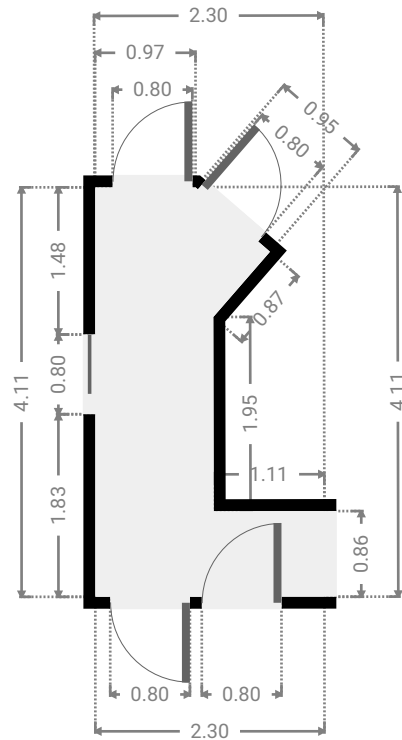
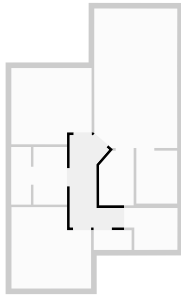

▼ **Bedroom**  
1st Floor

WIDTH: 3.55 m • LENGTH: 3.63 m  
AREA: 11.77 m<sup>2</sup> • PERIMETER: 14.36 m

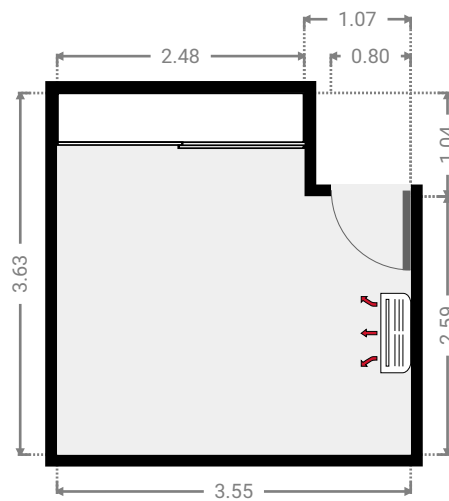
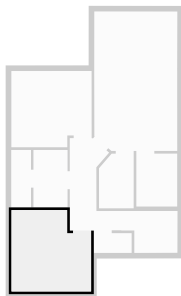

▼ **Closet**  
1st Floor

WIDTH: 1.69 m • LENGTH: 0.88 m  
AREA: 1.49 m<sup>2</sup> • PERIMETER: 5.14 m

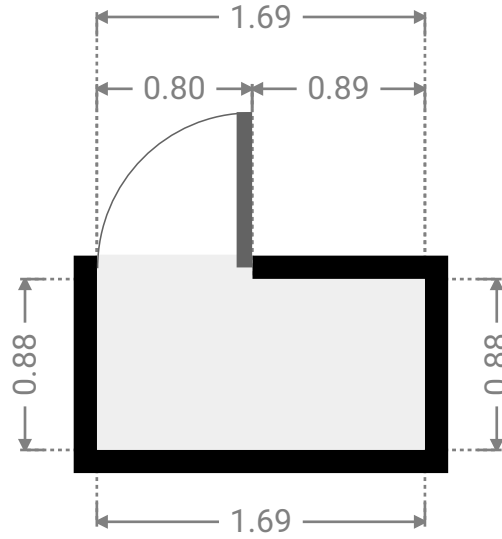
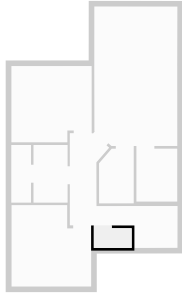

▼ **Bathroom**  
1st Floor

WIDTH: 1.52 m • LENGTH: 2.57 m  
AREA: 3.91 m<sup>2</sup> • PERIMETER: 8.18 m

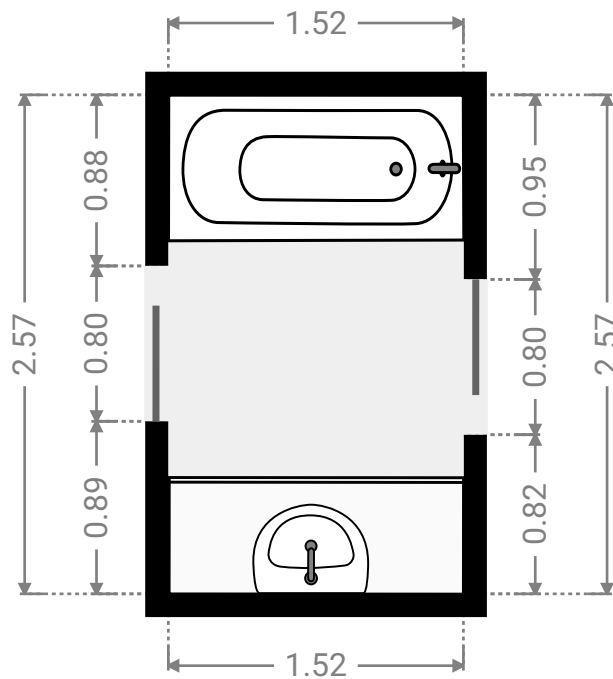
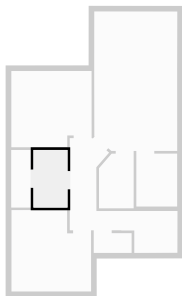

▼ Toilet  
1st Floor

WIDTH: 0.88 m • LENGTH: 2.57 m  
AREA: 2.26 m<sup>2</sup> • PERIMETER: 6.90 m

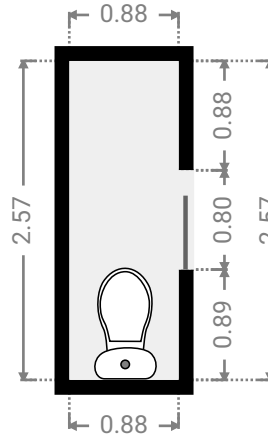
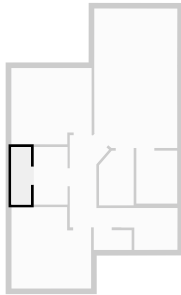

▼ Master Bedroom  
1st Floor

WIDTH: 3.70 m • LENGTH: 3.57 m  
AREA: 12.94 m<sup>2</sup> • PERIMETER: 14.12 m

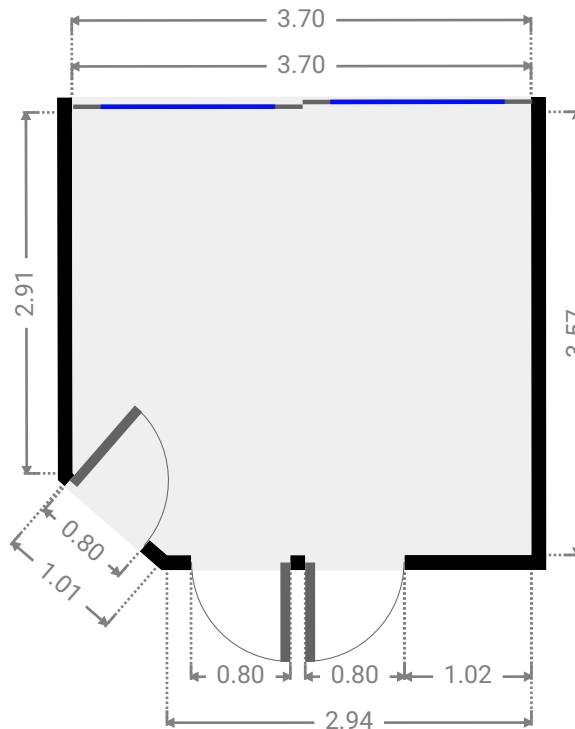
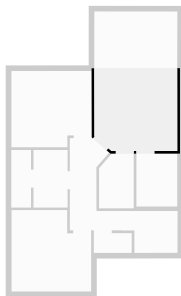

▼ Bathroom  
1st Floor

WIDTH: 1.82 m • LENGTH: 2.36 m  
AREA: 4.29 m<sup>2</sup> • PERIMETER: 8.36 m

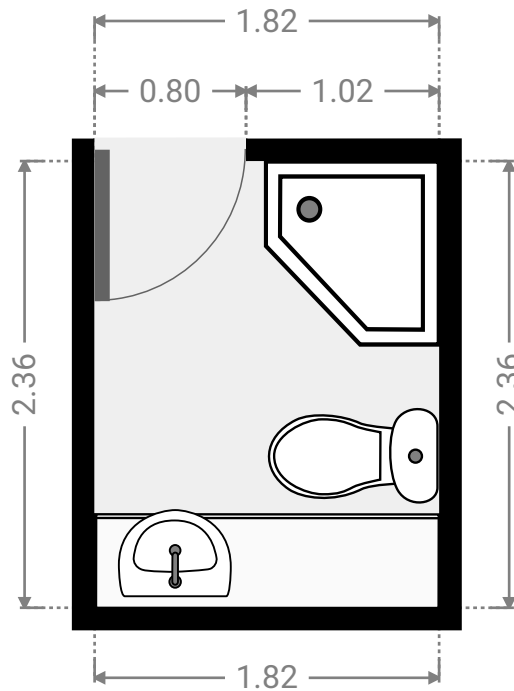
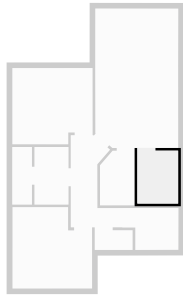

▼ Stairway  
1st Floor

WIDTH: 2.39 m • LENGTH: 1.87 m  
AREA: 3.99 m<sup>2</sup> • PERIMETER: 8.50 m

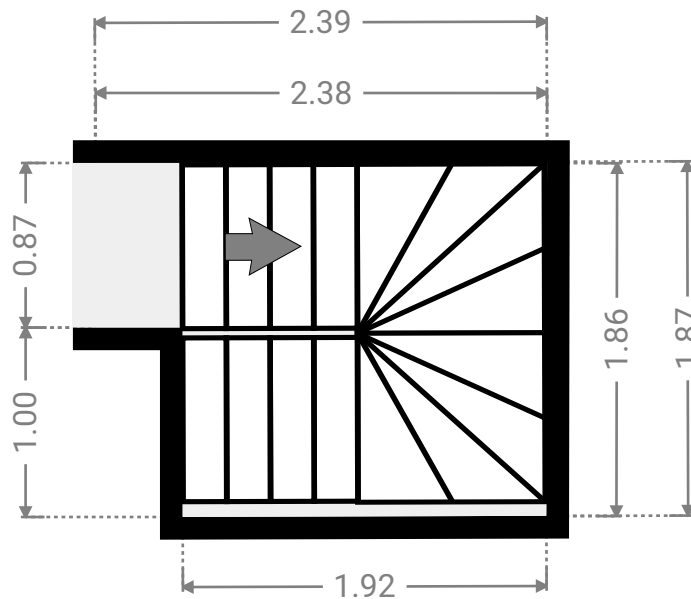
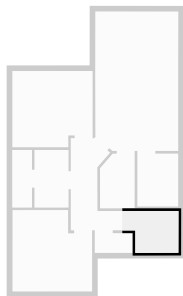

▼ **Closet**  
1st Floor

WIDTH: 1.55 m • LENGTH: 2.44 m  
AREA: 3.59 m<sup>2</sup> • PERIMETER: 7.62 m

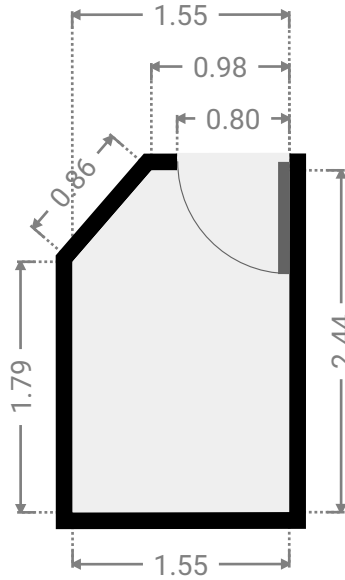
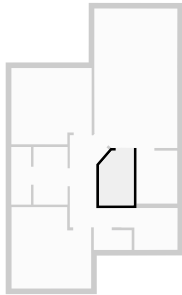

▼ **Bedroom**  
1st Floor

WIDTH: 3.58 m • LENGTH: 3.40 m  
AREA: 11.59 m<sup>2</sup> • PERIMETER: 13.96 m

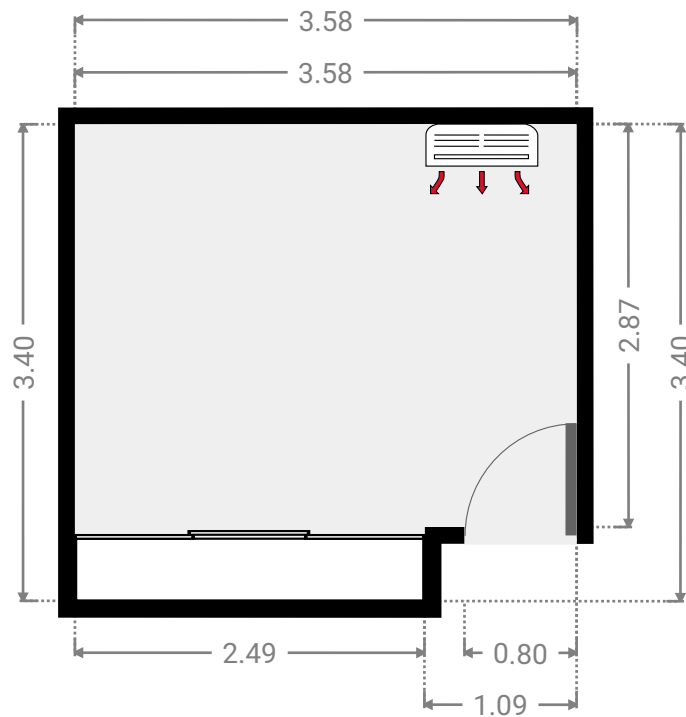
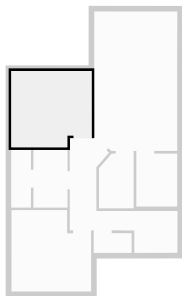

▼ Other  
1st Floor

WIDTH: 3.71 m • LENGTH: 2.54 m  
AREA: 9.36 m<sup>2</sup> • PERIMETER: 12.46 m

