

# 212A,B Empire

**SUBMITTED BY**  
Ray White Rockhampton

---

**CREATED ON**  
2022-11-07

---

**Floors**  
1

---

▼ 2nd Floor



▼ **Bathroom**  
2nd Floor

WIDTH: 1.50 m • LENGTH: 2.79 m  
AREA: 4.19 m<sup>2</sup> • PERIMETER: 8.59 m

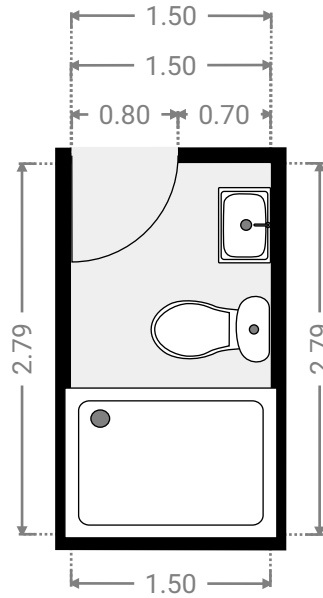
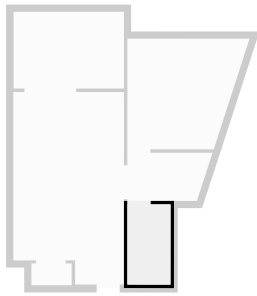

▼ **Bedroom**  
2nd Floor

WIDTH: 4.25 m • LENGTH: 3.85 m  
AREA: 13.96 m<sup>2</sup> • PERIMETER: 15.15 m

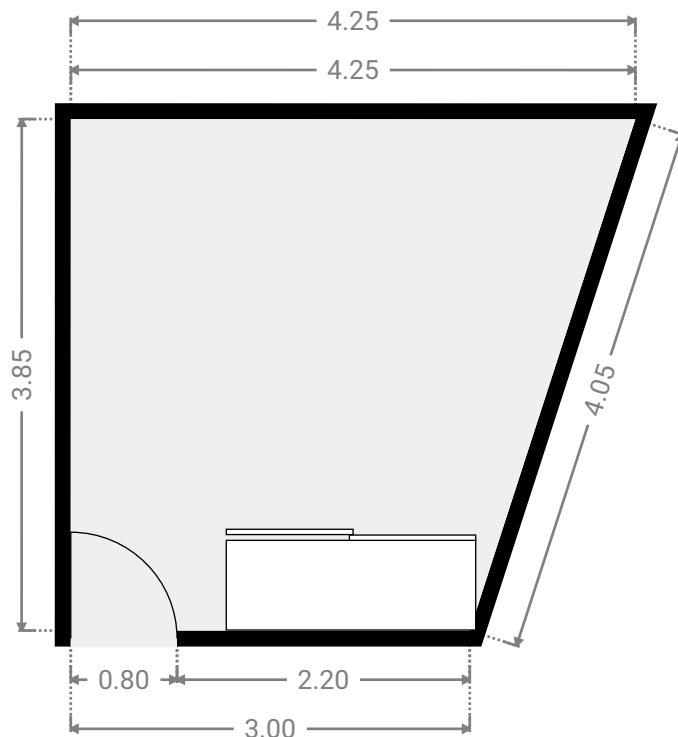
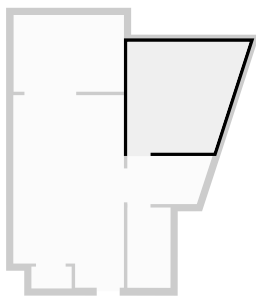

▼ **Hall**  
2nd Floor

WIDTH: 3.85 m • LENGTH: 6.70 m  
AREA: 23.99 m<sup>2</sup> • PERIMETER: 21.10 m

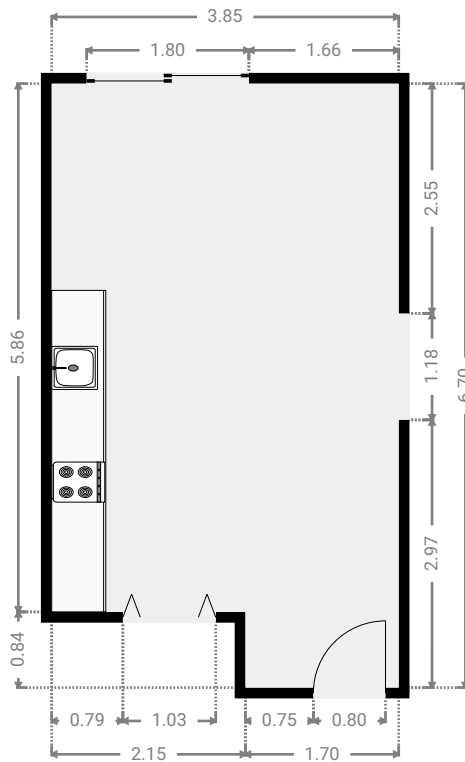
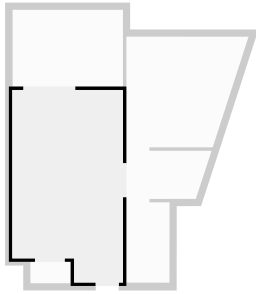

▼ **Hall**  
2nd Floor

WIDTH: 2.97 m • LENGTH: 1.68 m  
AREA: 4.51 m<sup>2</sup> • PERIMETER: 8.82 m

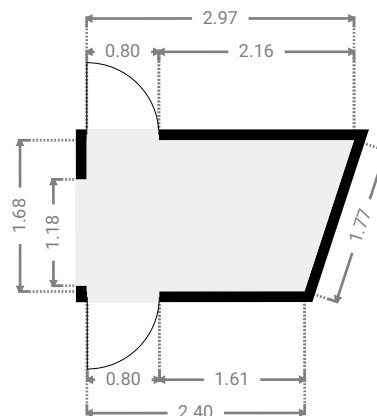
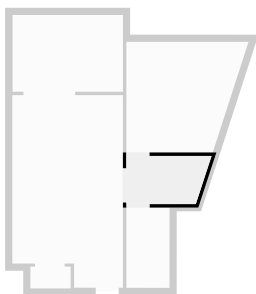

▼ **Music Room**  
2nd Floor

WIDTH: 1.40 m • LENGTH: 0.76 m  
AREA: 1.06 m<sup>2</sup> • PERIMETER: 4.32 m

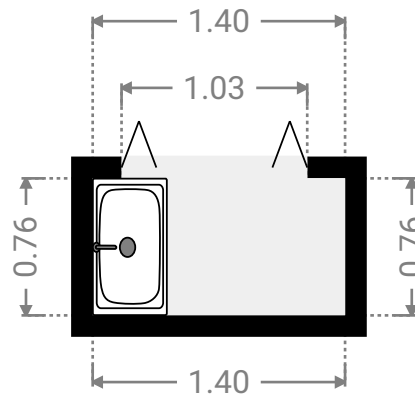
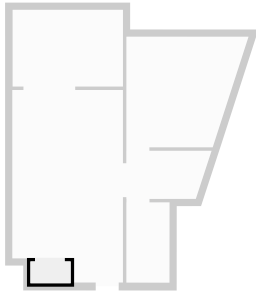

▼ **Other**  
2nd Floor

WIDTH: 3.84 m • LENGTH: 2.67 m  
AREA: 10.26 m<sup>2</sup> • PERIMETER: 13.02 m

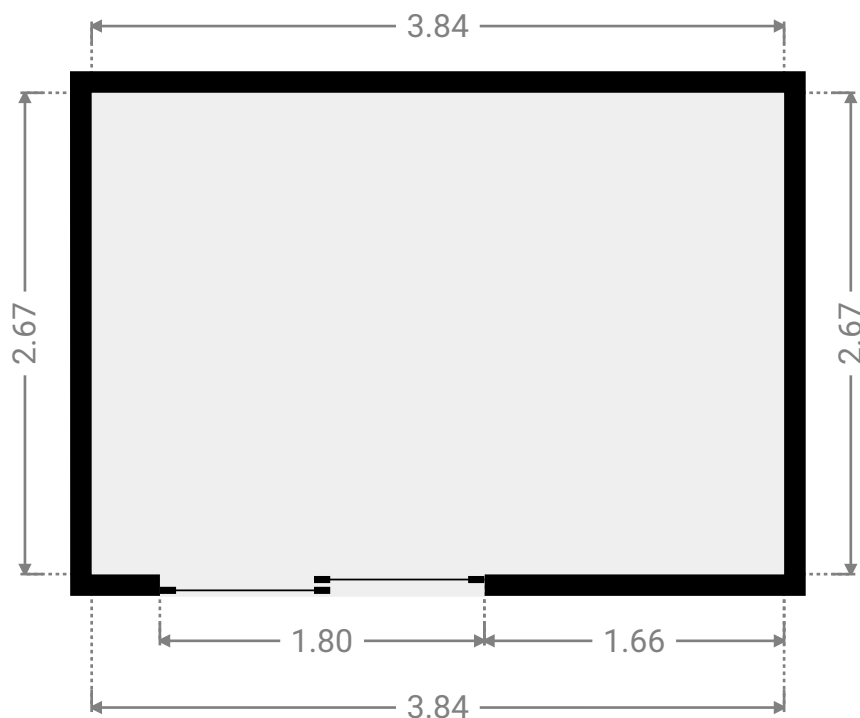
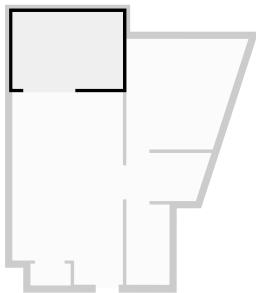

# 212 B The Empire

**SUBMITTED BY**

Ray White Rockhampton Casey  
stockers@cqoz.com

---

**CREATED ON**

2022-11-07

---

**Floors**

1

---

▼ 2nd Floor

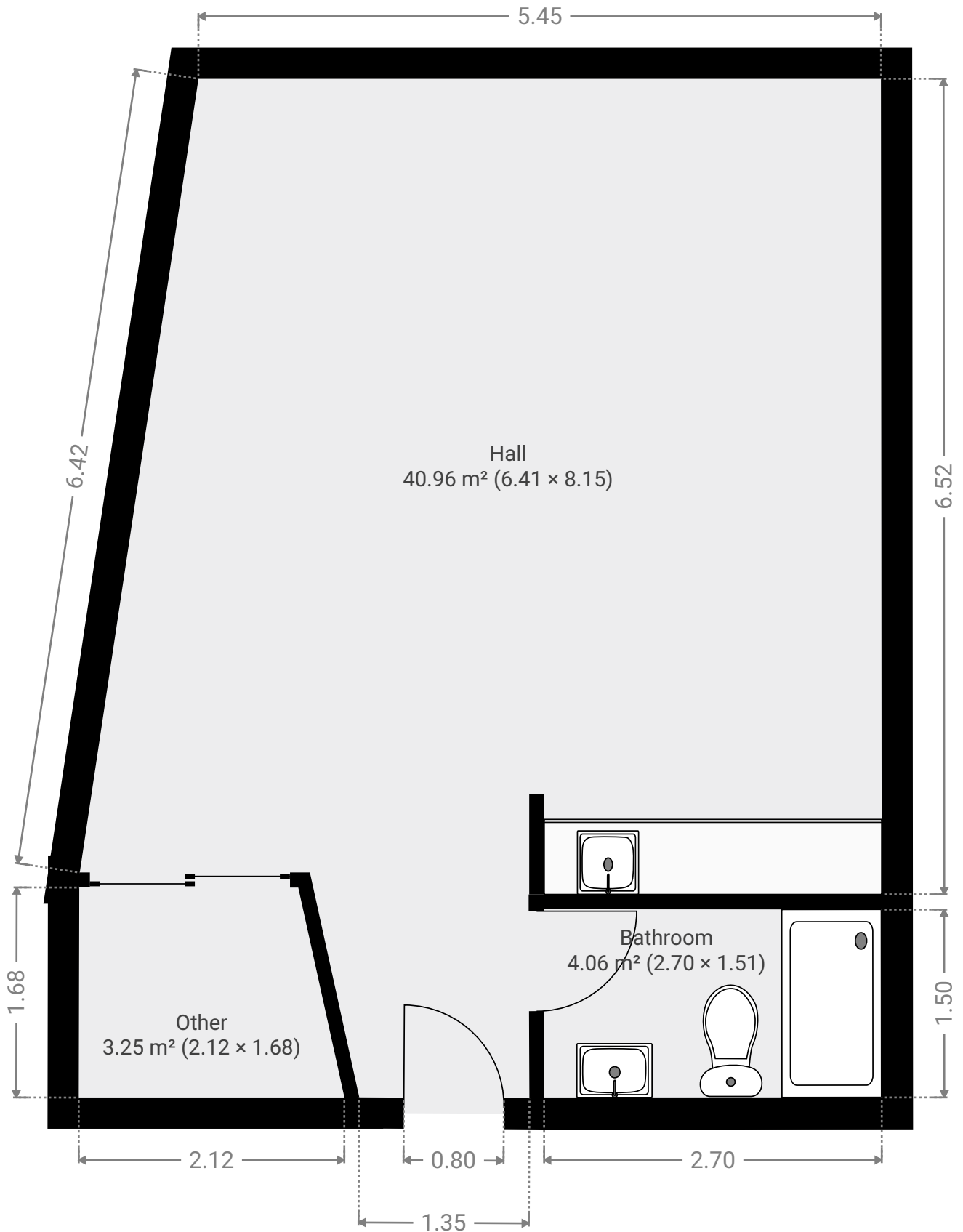

FLOORS: 1

▼ Bathroom  
2nd Floor

WIDTH: 2.70 m • LENGTH: 1.51 m  
AREA: 4.06 m<sup>2</sup> • PERIMETER: 8.41 m

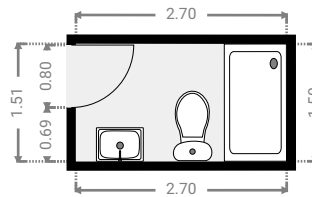
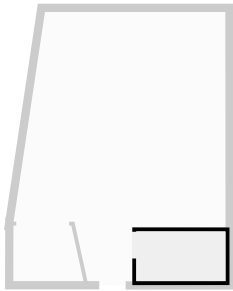

▼ Hall  
2nd Floor

WIDTH: 6.41 m • LENGTH: 8.15 m  
AREA: 40.96 m<sup>2</sup> • PERIMETER: 27.89 m

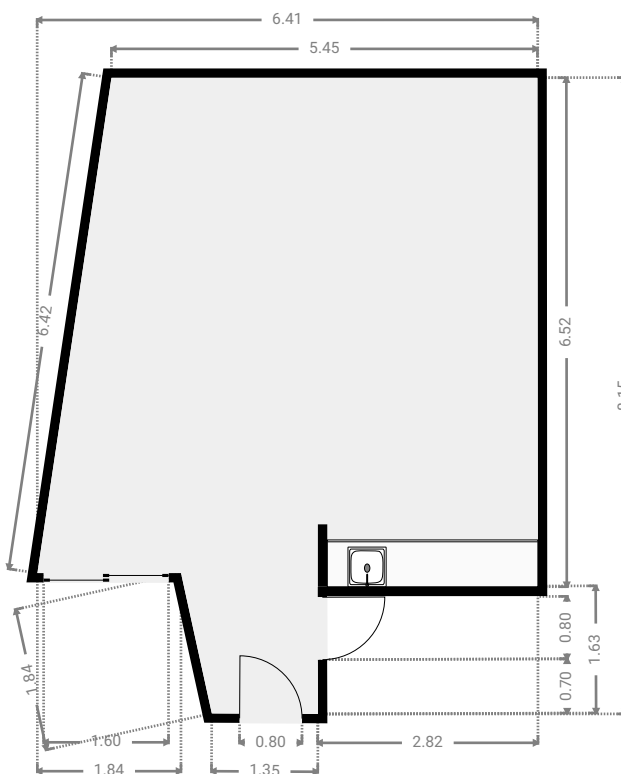
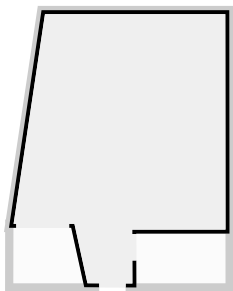



▼ Other  
2nd Floor

WIDTH: 2.12 m • LENGTH: 1.68 m  
AREA: 3.25 m<sup>2</sup> • PERIMETER: 7.27 m

