

Unit 1/222 Ford Street

SUBMITTED BY
Ray White Rockhampton Casey
stockers@cqoz.com

CREATED ON
2018-01-09

Floors 1

▼ Ground Floor

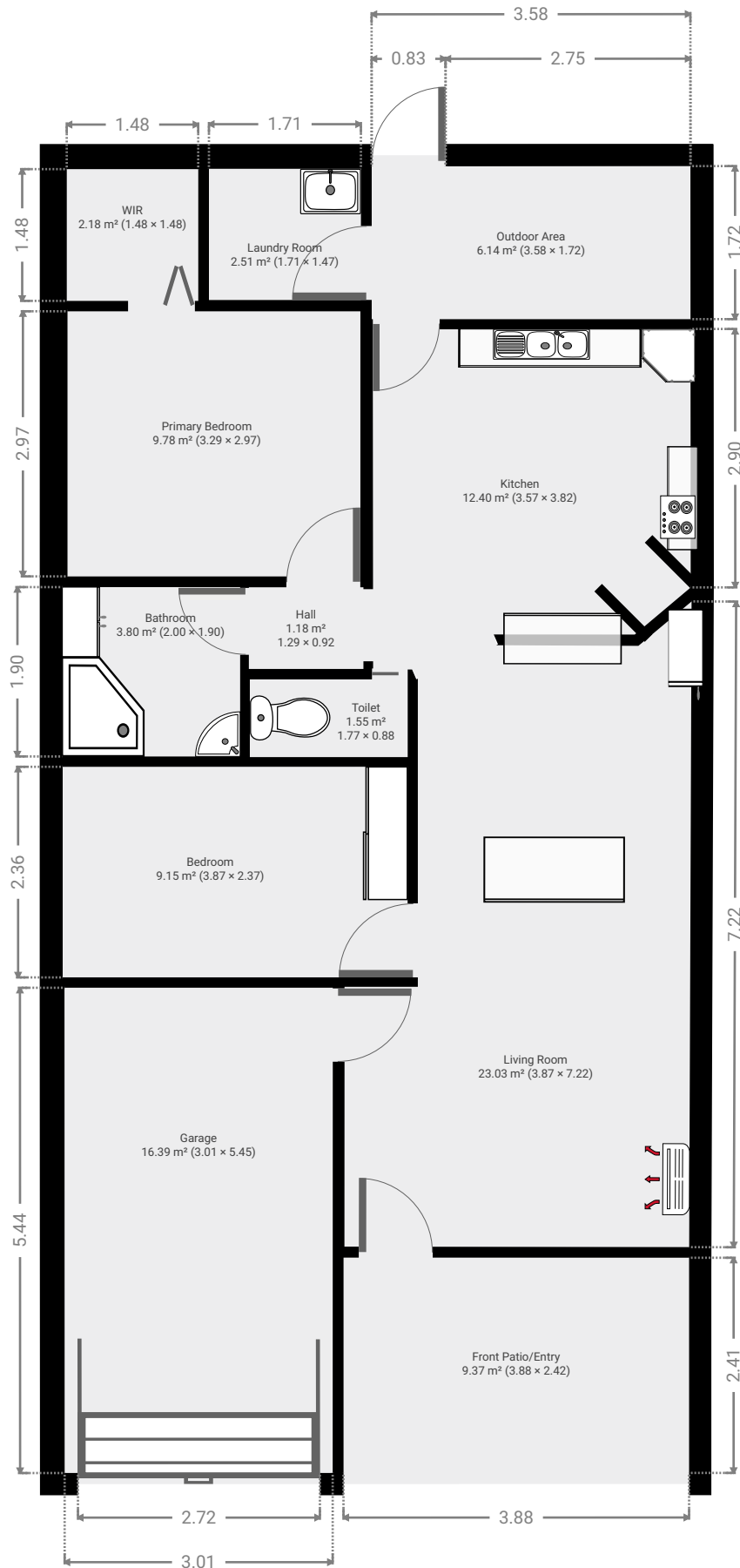

FLOORS: 1

▼ Living Room
Ground Floor

WIDTH: 3.87 m • LENGTH: 7.22 m
AREA: 23.03 m² • PERIMETER: 21.64 m

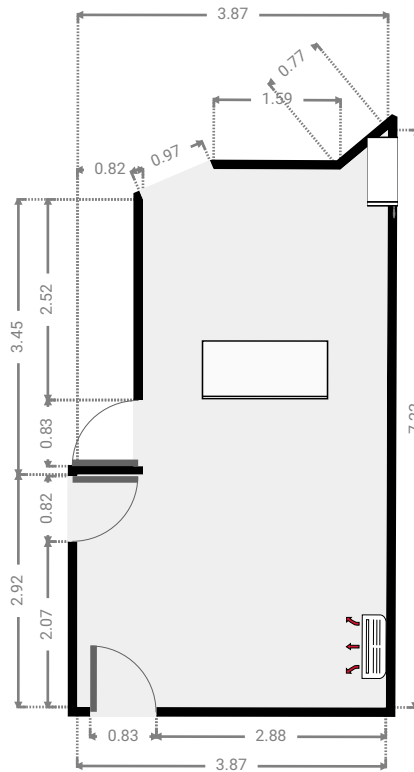
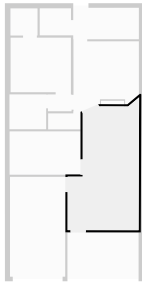

▼ Garage
Ground Floor

WIDTH: 3.01 m • LENGTH: 5.45 m
AREA: 16.39 m² • PERIMETER: 16.91 m

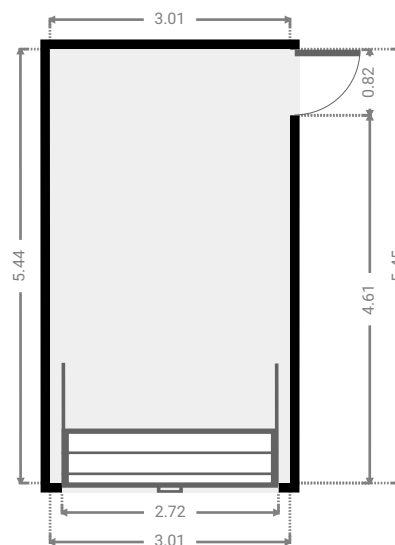
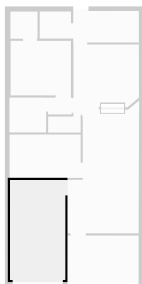

FLOORS: 1

▼ **Kitchen**
Ground Floor

WIDTH: 3.57 m • LENGTH: 3.82 m
AREA: 12.40 m² • PERIMETER: 14.12 m

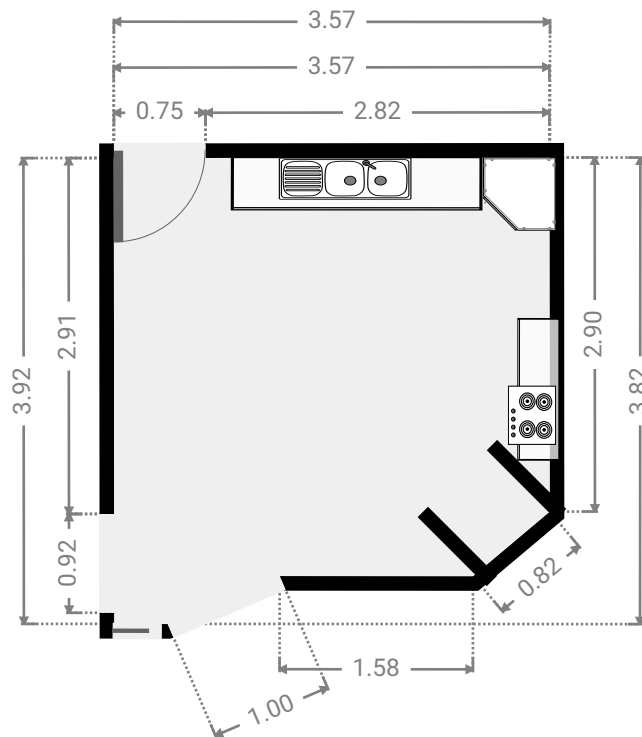
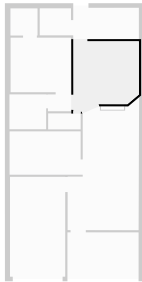

▼ **Hall**
Ground Floor

WIDTH: 1.29 m • LENGTH: 0.92 m
AREA: 1.18 m² • PERIMETER: 4.40 m

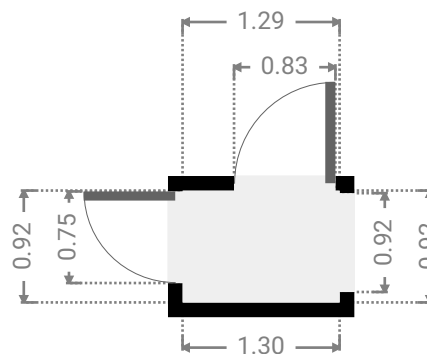
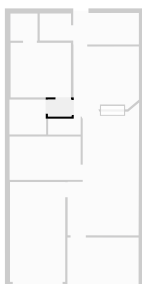

FLOORS: 1

▼ **Primary Bedroom**
Ground Floor

WIDTH: 3.29 m • LENGTH: 2.97 m
AREA: 9.78 m² • PERIMETER: 12.52 m

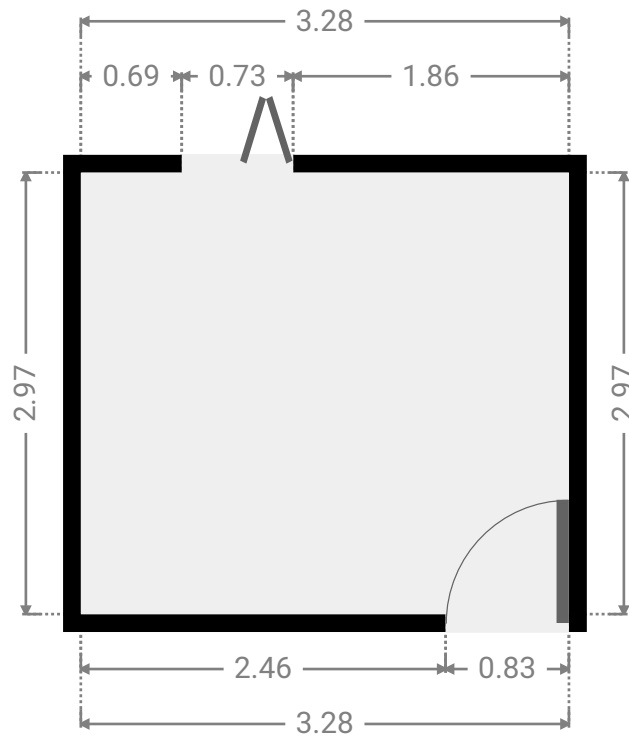
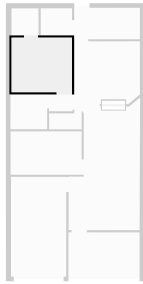

▼ **Bathroom**
Ground Floor

WIDTH: 2.00 m • LENGTH: 1.90 m
AREA: 3.80 m² • PERIMETER: 7.80 m

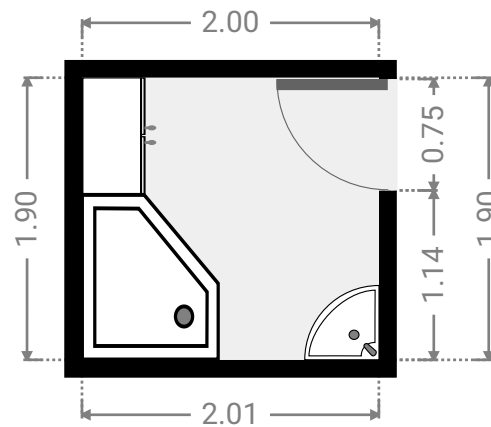
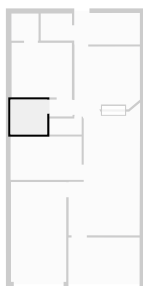

FLOORS: 1

▼ **Toilet**
Ground Floor

WIDTH: 1.77 m • LENGTH: 0.88 m
AREA: 1.55 m² • PERIMETER: 5.29 m

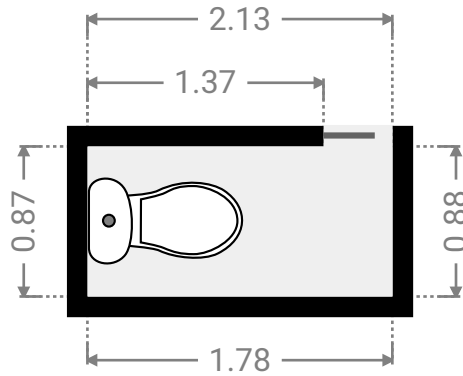
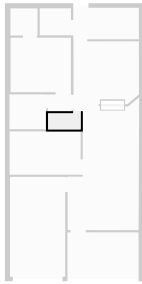

▼ **Bedroom**
Ground Floor

WIDTH: 3.87 m • LENGTH: 2.37 m
AREA: 9.15 m² • PERIMETER: 12.47 m

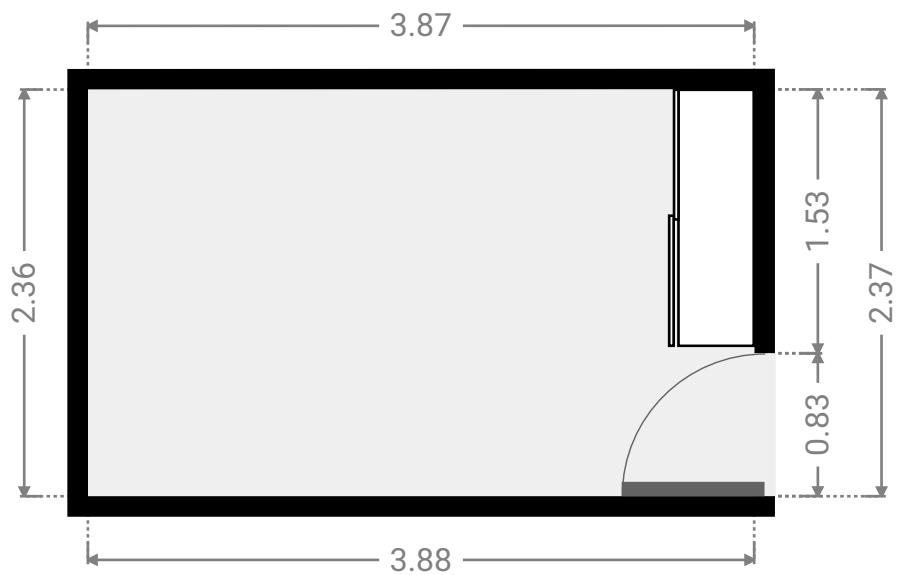
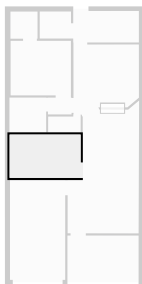

FLOORS: 1

▼ **Outdoor Area**
Ground Floor

WIDTH: 3.58 m • LENGTH: 1.72 m
AREA: 6.14 m² • PERIMETER: 10.59 m

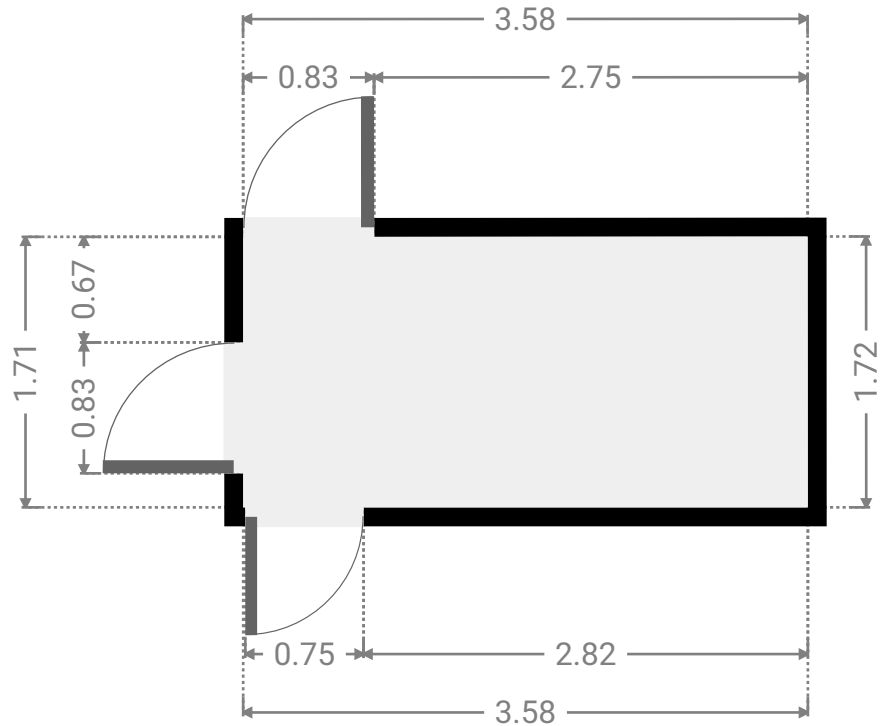

▼ **Laundry Room**
Ground Floor

WIDTH: 1.71 m • LENGTH: 1.47 m
AREA: 2.51 m² • PERIMETER: 6.36 m

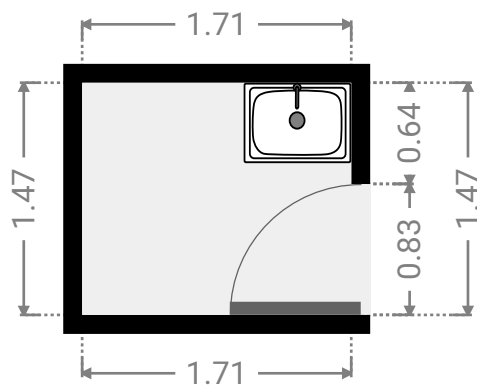
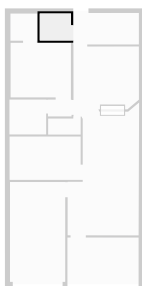

FLOORS: 1

▼ **WIR**
Ground Floor

WIDTH: 1.48 m • LENGTH: 1.48 m
AREA: 2.18 m² • PERIMETER: 5.91 m

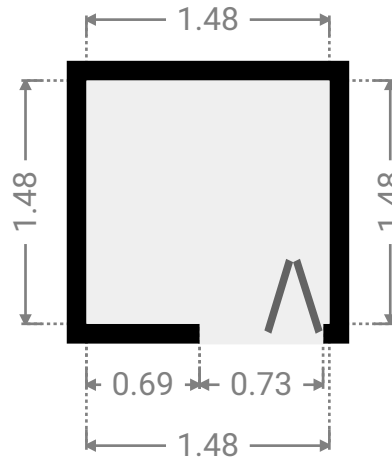
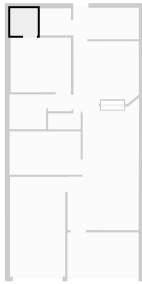

▼ **Front Patio/Entry**
Ground Floor

WIDTH: 3.88 m • LENGTH: 2.42 m
AREA: 9.37 m² • PERIMETER: 12.59 m

