

# Unit 1/15 Parkside Place

Created on  
2017-08-08

Floors  
1



## ▼ Ground Floor

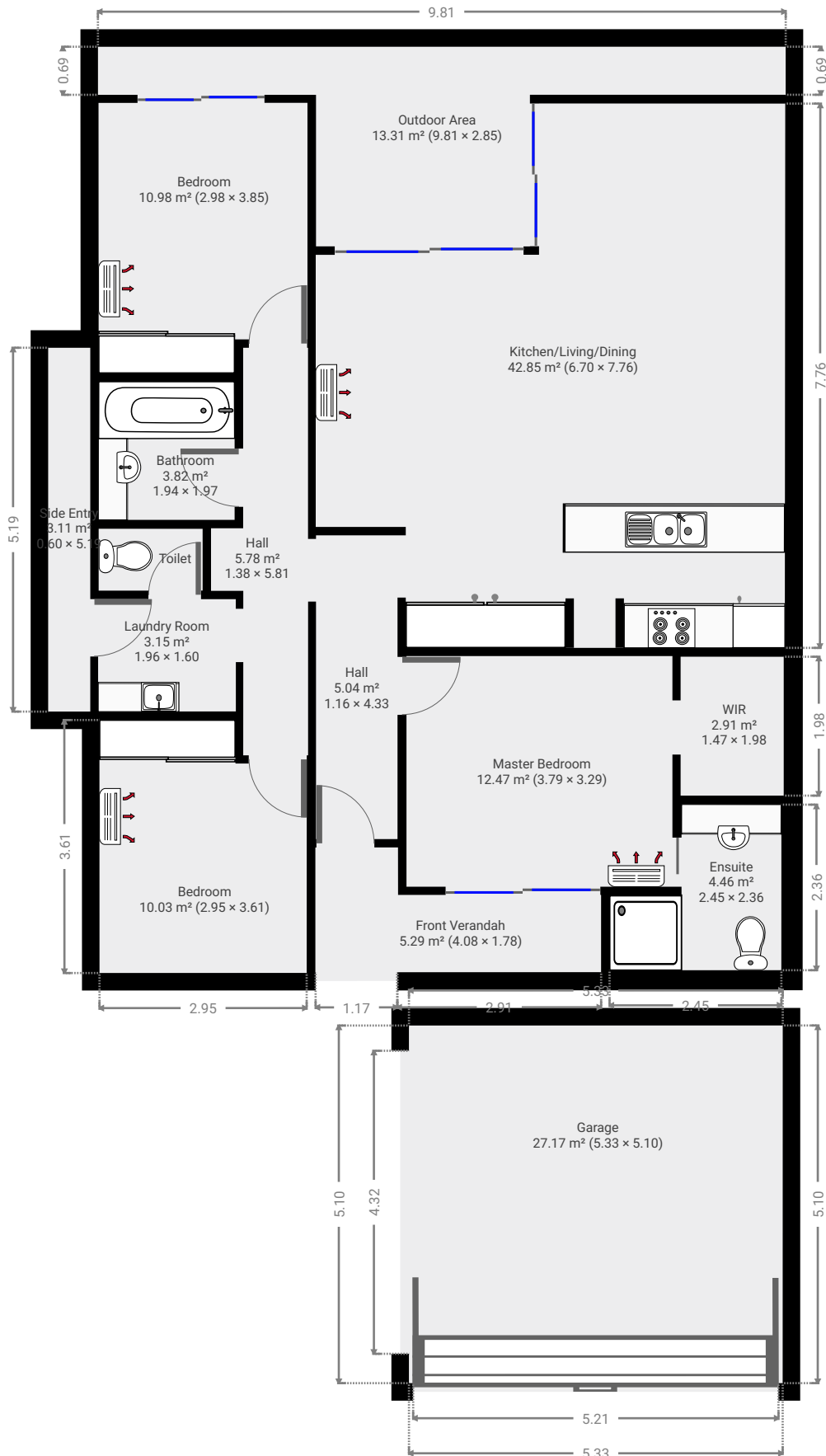

▼ Hall  
Ground Floor

WIDTH: 1.16 m • LENGTH: 4.33 m  
AREA: 5.04 m<sup>2</sup> • PERIMETER: 10.99 m

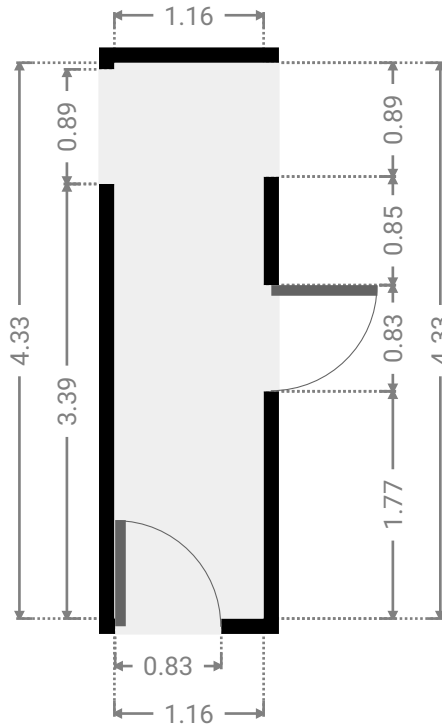
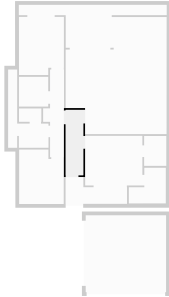

▼ Master Bedroom  
Ground Floor

WIDTH: 3.79 m • LENGTH: 3.29 m  
AREA: 12.47 m<sup>2</sup> • PERIMETER: 14.16 m

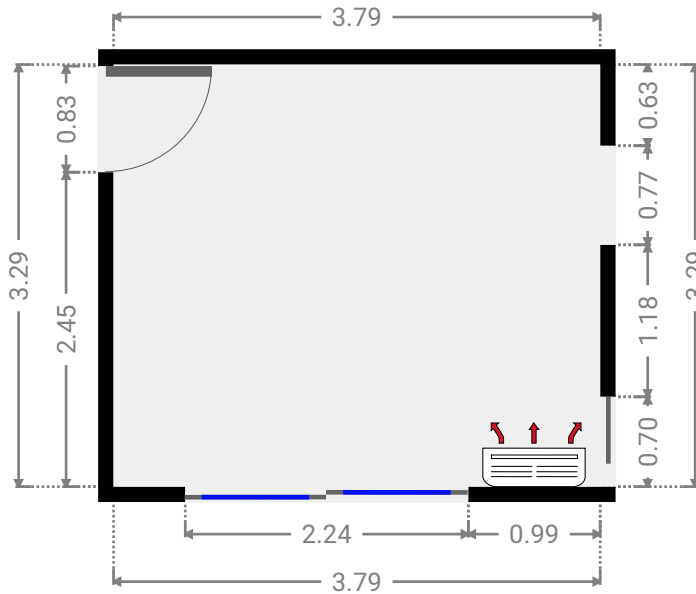
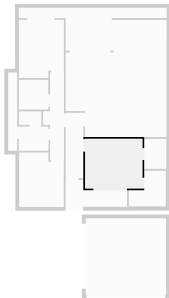

▼ **Ensuite**  
Ground Floor

WIDTH: 2.45 m • LENGTH: 2.36 m  
AREA: 4.46 m<sup>2</sup> • PERIMETER: 9.62 m

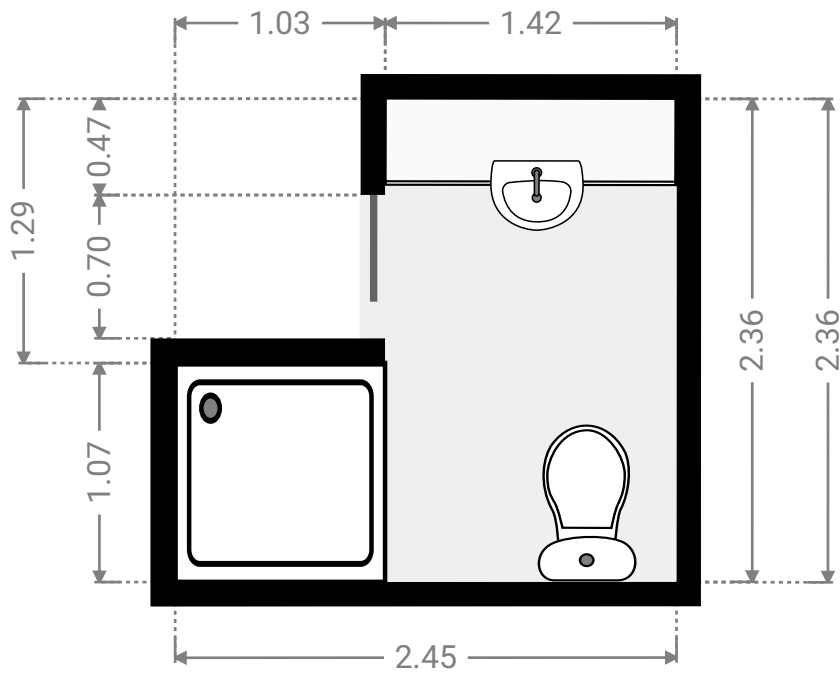
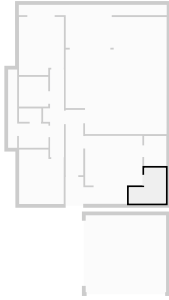

▼ **WIR**  
Ground Floor

WIDTH: 1.47 m • LENGTH: 1.98 m  
AREA: 2.91 m<sup>2</sup> • PERIMETER: 6.90 m

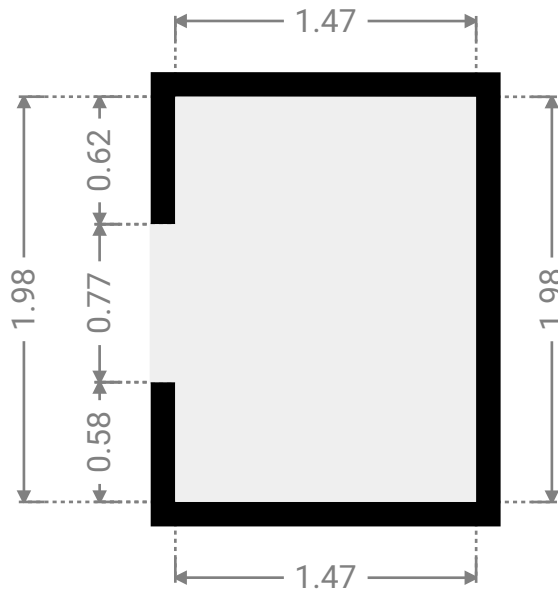
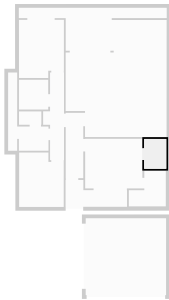

▼ Kitchen/Living/Dining  
Ground Floor

WIDTH: 6.70 m • LENGTH: 7.76 m  
AREA: 42.85 m<sup>2</sup> • PERIMETER: 28.90 m

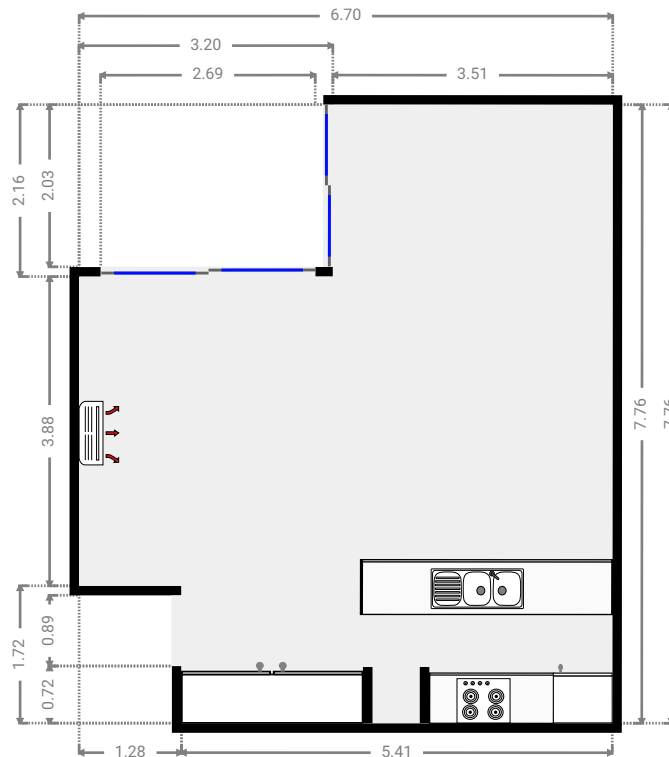
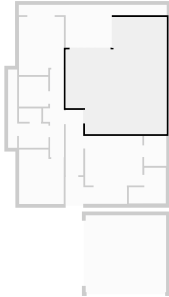

▼ Hall  
Ground Floor

WIDTH: 1.38 m • LENGTH: 5.81 m  
AREA: 5.78 m<sup>2</sup> • PERIMETER: 14.39 m

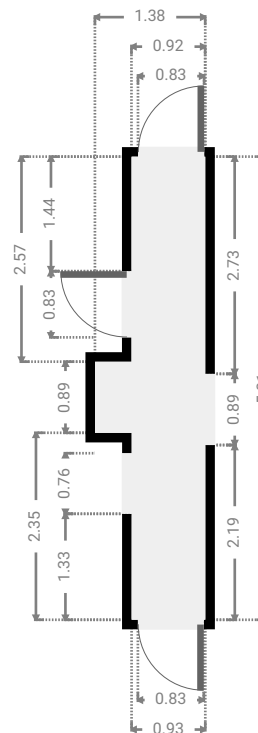
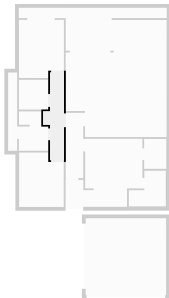

FLOORS: 1

▼ **Bedroom**  
Ground Floor

WIDTH: 2.95 m • LENGTH: 3.61 m  
AREA: 10.03 m<sup>2</sup> • PERIMETER: 13.12 m

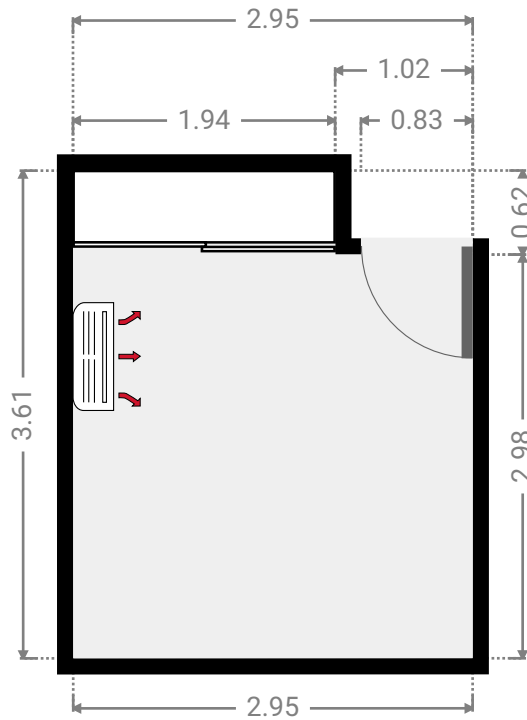
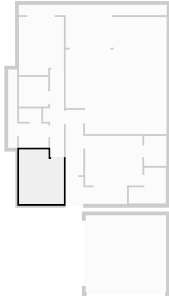

▼ **Laundry Room**  
Ground Floor

WIDTH: 1.96 m • LENGTH: 1.60 m  
AREA: 3.15 m<sup>2</sup> • PERIMETER: 7.13 m

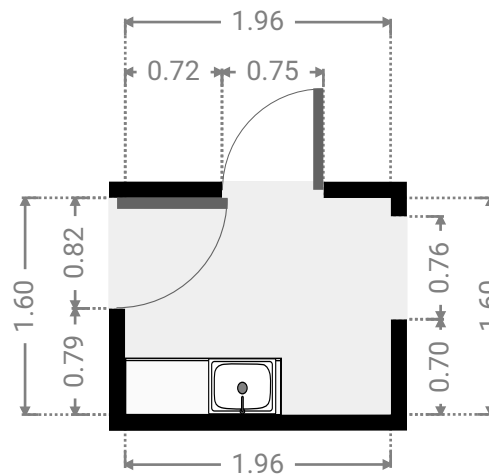
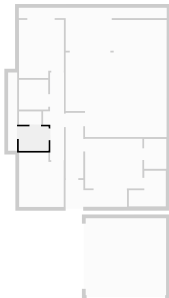

▼ **Toilet**  
Ground Floor

WIDTH: 1.48 m • LENGTH: 0.88 m  
AREA: 1.31 m<sup>2</sup> • PERIMETER: 4.73 m

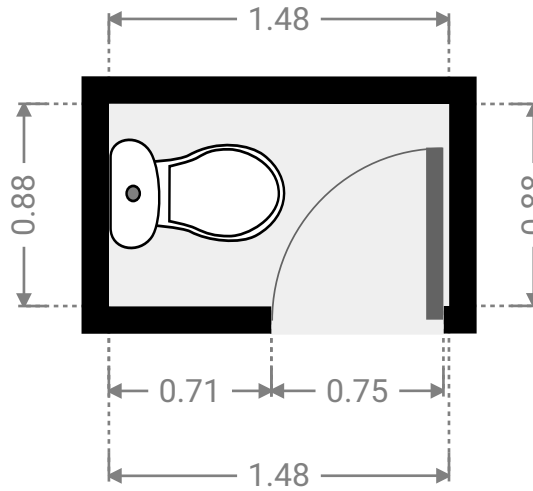
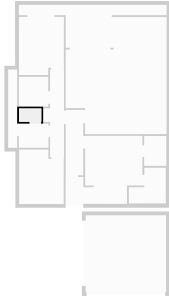

▼ **Bathroom**  
Ground Floor

WIDTH: 1.94 m • LENGTH: 1.97 m  
AREA: 3.82 m<sup>2</sup> • PERIMETER: 7.82 m

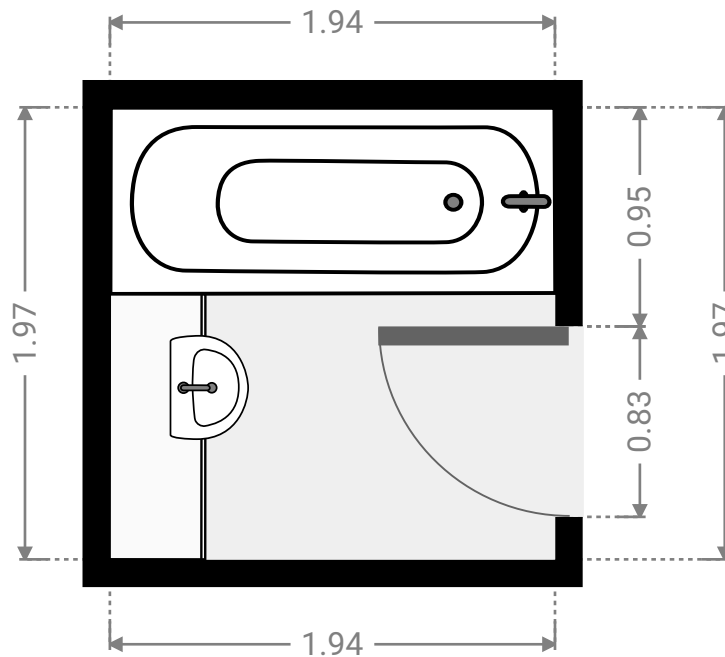
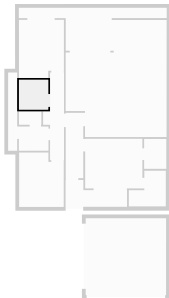

## ▼ Bedroom Ground Floor

WIDTH: 2.98 m • LENGTH: 3.85 m  
AREA: 10.98 m<sup>2</sup> • PERIMETER: 13.66 m

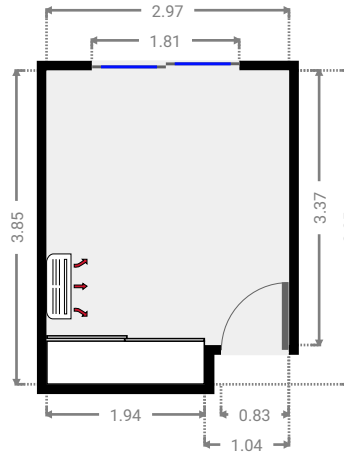
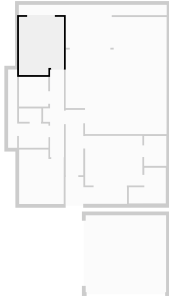

## ▼ Outdoor Area Ground Floor

WIDTH: 9.81 m • LENGTH: 2.85 m  
AREA: 13.31 m<sup>2</sup> • PERIMETER: 25.31 m

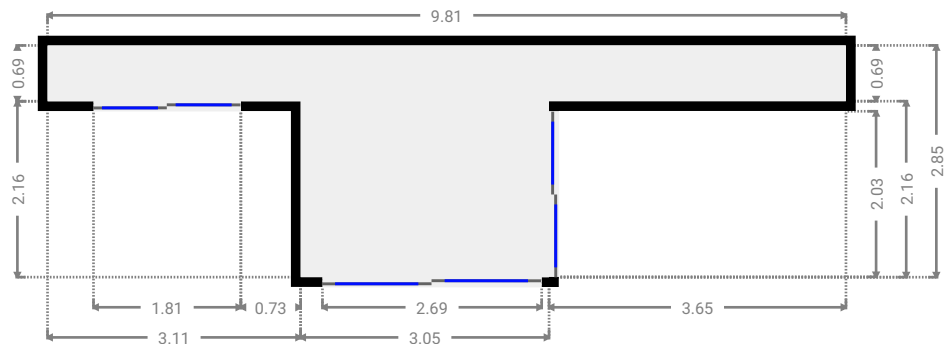



FLOORS: 1

▼ Front Verandah  
Ground Floor

WIDTH: 4.08 m • LENGTH: 1.78 m  
AREA: 5.29 m<sup>2</sup> • PERIMETER: 11.71 m

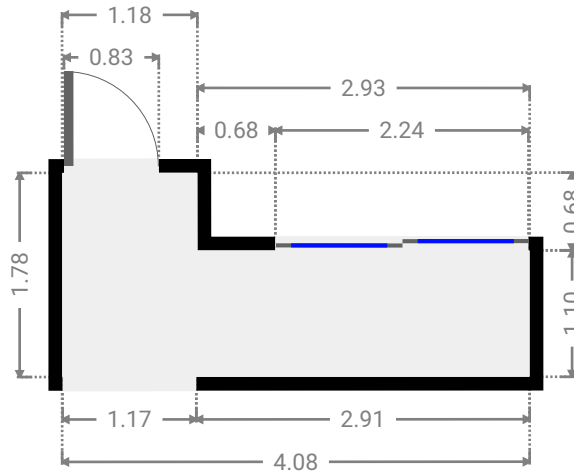
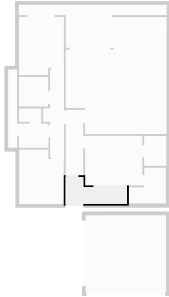

▼ Garage  
Ground Floor

WIDTH: 5.33 m • LENGTH: 5.10 m  
AREA: 27.17 m<sup>2</sup> • PERIMETER: 20.86 m

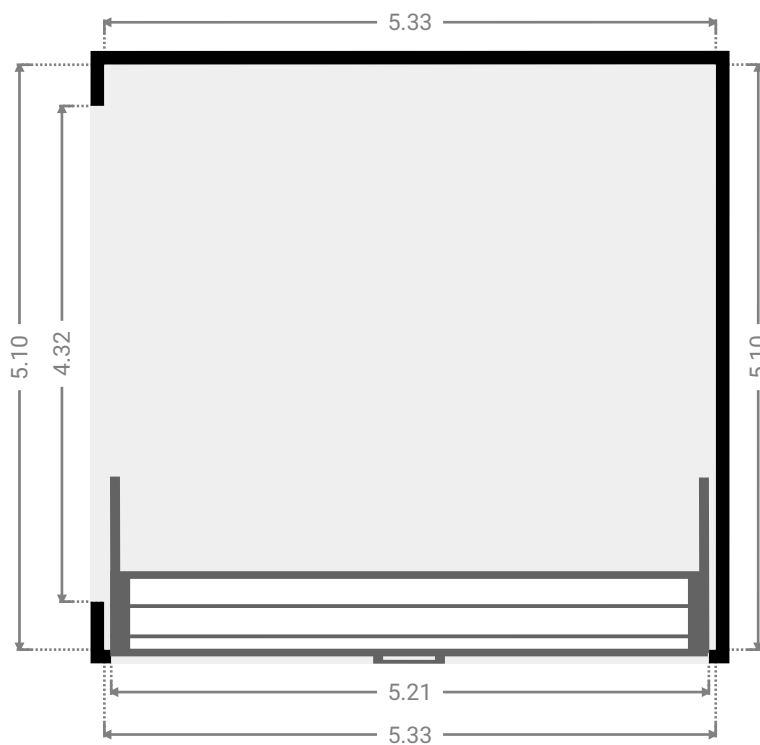
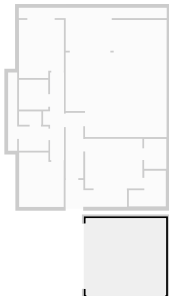

▼ **Side Entry**  
Ground Floor

WIDTH: 0.60 m • LENGTH: 5.19 m  
AREA: 3.11 m<sup>2</sup> • PERIMETER: 11.57 m

