

99 Constance Avenue

SUBMITTED BY

Ray White Rockhampton Casey
stockers@cqoz.com

CREATED ON

2022-11-14

Floors

1

▼ Ground Floor

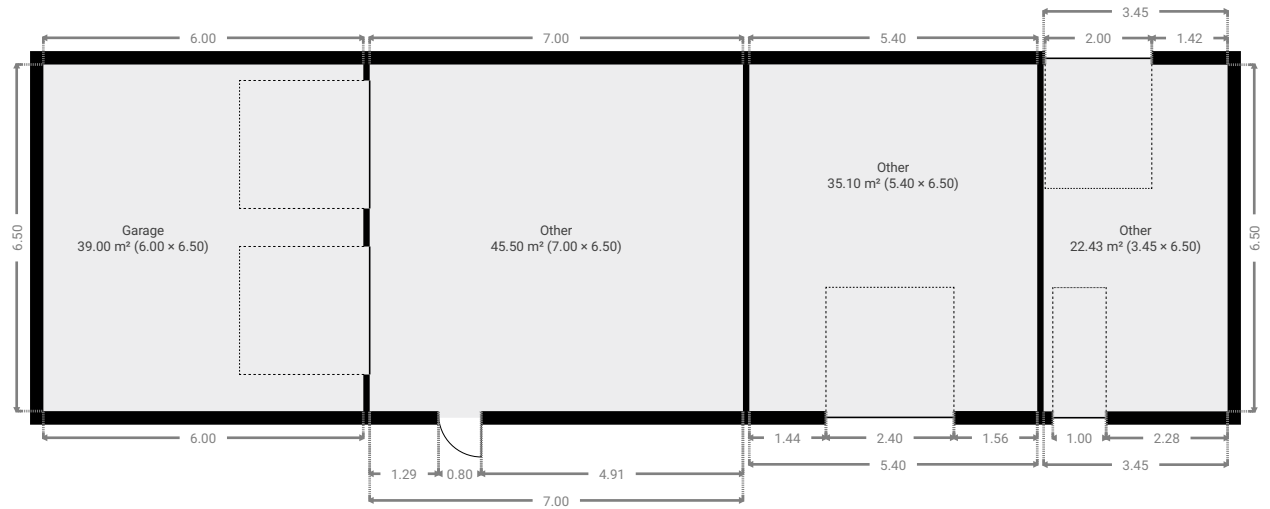

FLOORS: 1

▼ **Bathroom**
Ground Floor

WIDTH: 1.95 m • LENGTH: 2.38 m
AREA: 4.64 m² • PERIMETER: 8.66 m

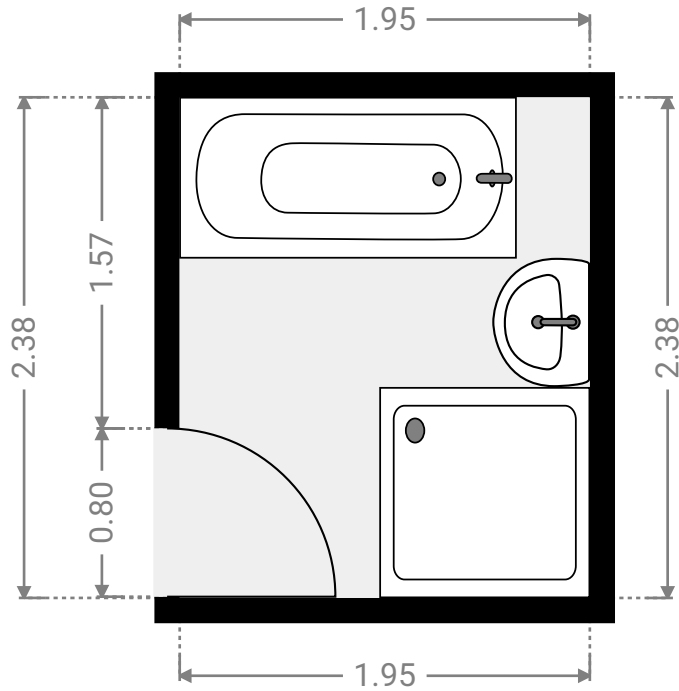

▼ **Bathroom**
Ground Floor

WIDTH: 2.21 m • LENGTH: 1.73 m
AREA: 3.81 m² • PERIMETER: 7.86 m

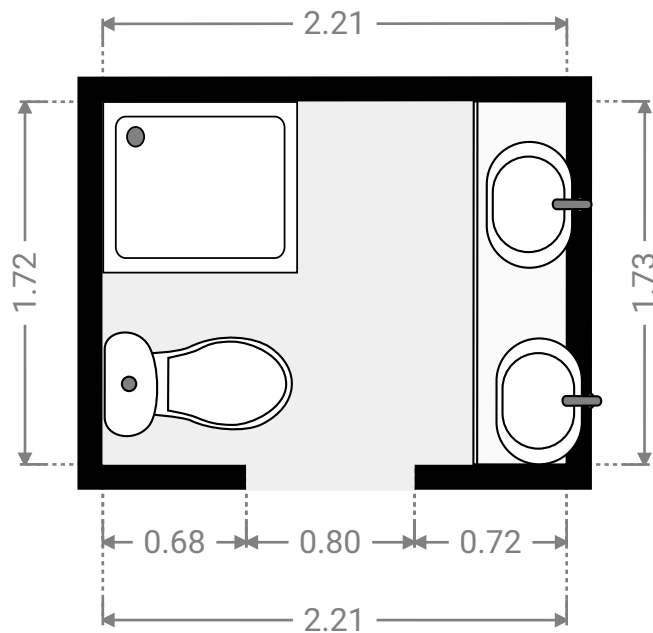

FLOORS: 1

▼ **Bedroom**
Ground Floor

WIDTH: 4.12 m • LENGTH: 2.99 m
AREA: 11.46 m² • PERIMETER: 14.21 m

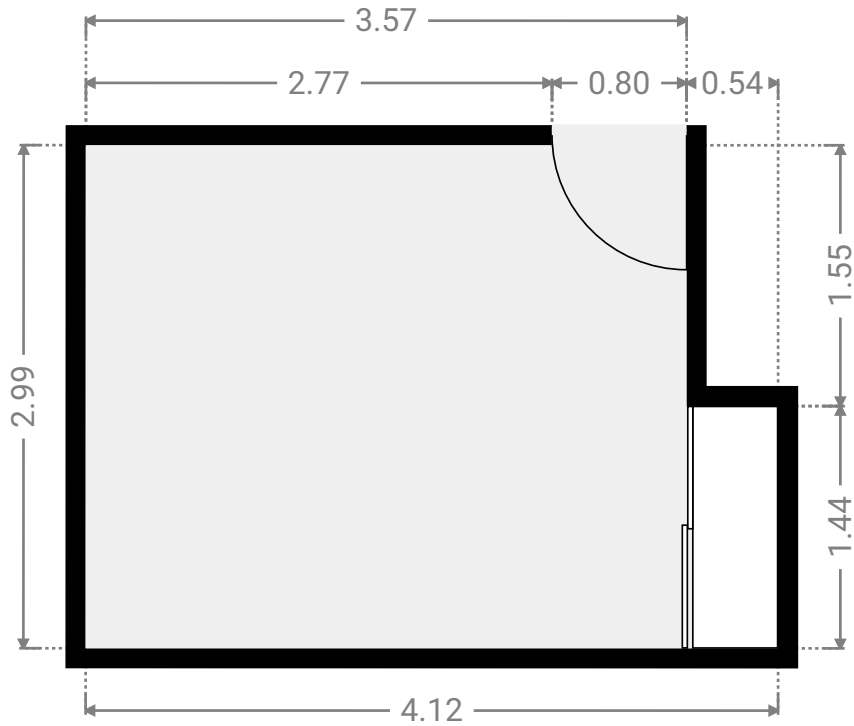

▼ **Bedroom**
Ground Floor

WIDTH: 2.96 m • LENGTH: 2.98 m
AREA: 8.82 m² • PERIMETER: 11.88 m

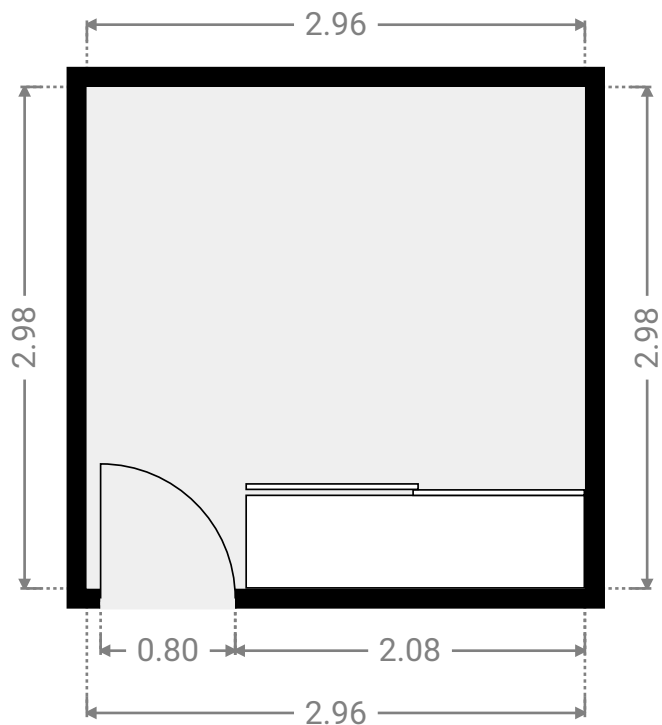
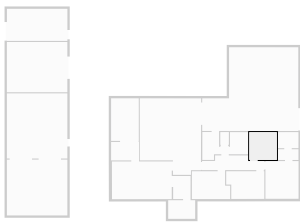

FLOORS: 1

▼ **Bedroom**
Ground Floor

WIDTH: 3.56 m • LENGTH: 4.05 m
AREA: 14.42 m² • PERIMETER: 15.22 m

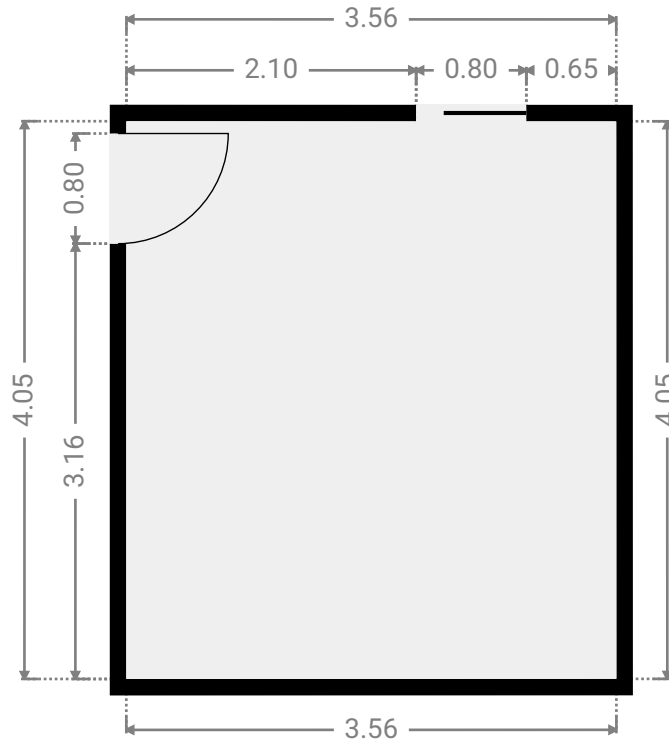

▼ **Bedroom**
Ground Floor

WIDTH: 4.09 m • LENGTH: 2.98 m
AREA: 11.34 m² • PERIMETER: 14.14 m

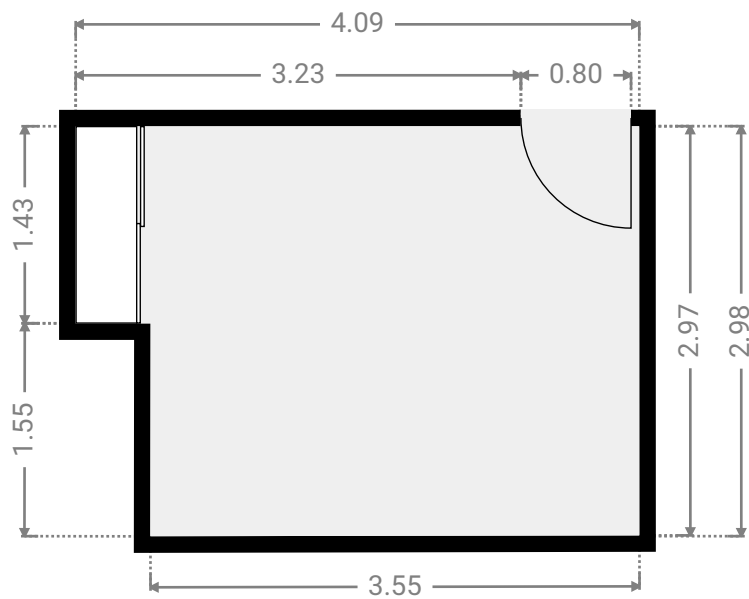
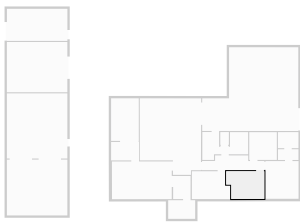

FLOORS: 1

▼ **Closet**
Ground Floor

WIDTH: 2.20 m • LENGTH: 1.15 m
AREA: 2.53 m² • PERIMETER: 6.70 m

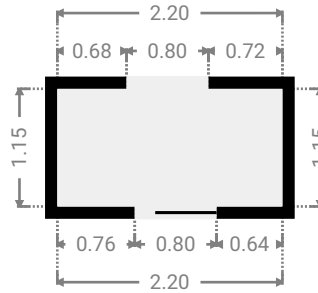

▼ **Garage**
Ground Floor

WIDTH: 6.50 m • LENGTH: 6.00 m
AREA: 39.00 m² • PERIMETER: 25.00 m

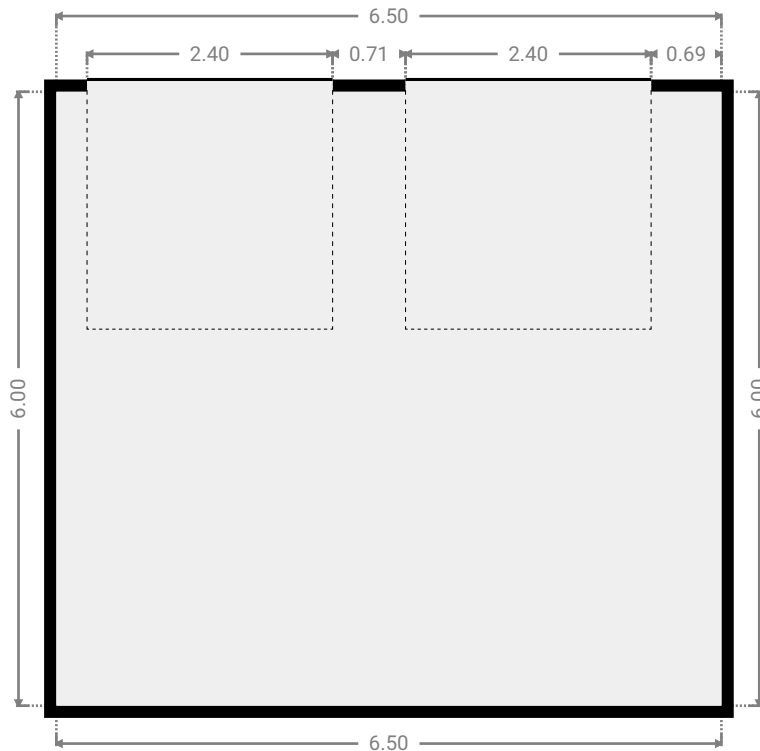

FLOORS: 1

▼ **Hall**
Ground Floor

WIDTH: 1.87 m • LENGTH: 2.48 m
AREA: 4.64 m² • PERIMETER: 8.70 m

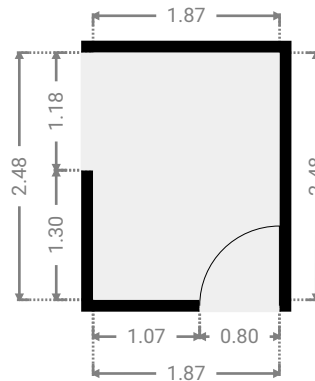

▼ **Hall**
Ground Floor

WIDTH: 6.70 m • LENGTH: 1.58 m
AREA: 8.70 m² • PERIMETER: 16.56 m

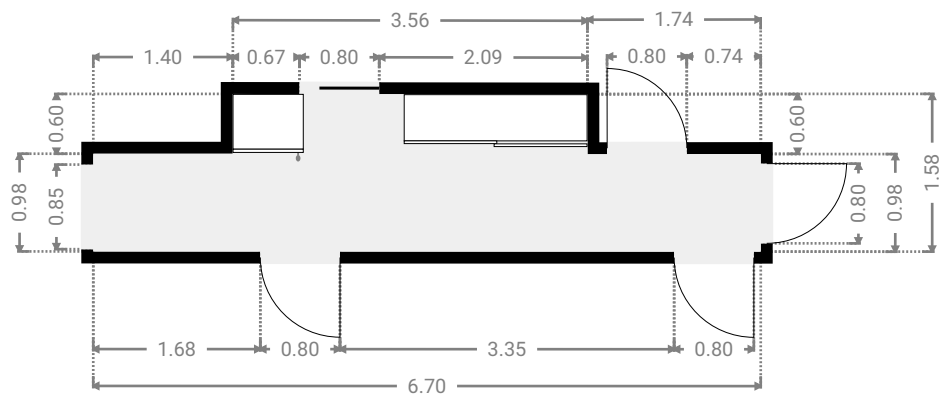

FLOORS: 1

▼ **Hall**
Ground Floor

WIDTH: 0.90 m • LENGTH: 0.90 m
AREA: 0.81 m² • PERIMETER: 3.60 m

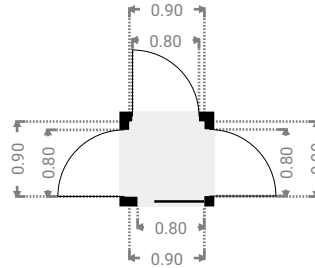

▼ **Kitchen**
Ground Floor

WIDTH: 6.60 m • LENGTH: 8.22 m
AREA: 48.04 m² • PERIMETER: 29.61 m

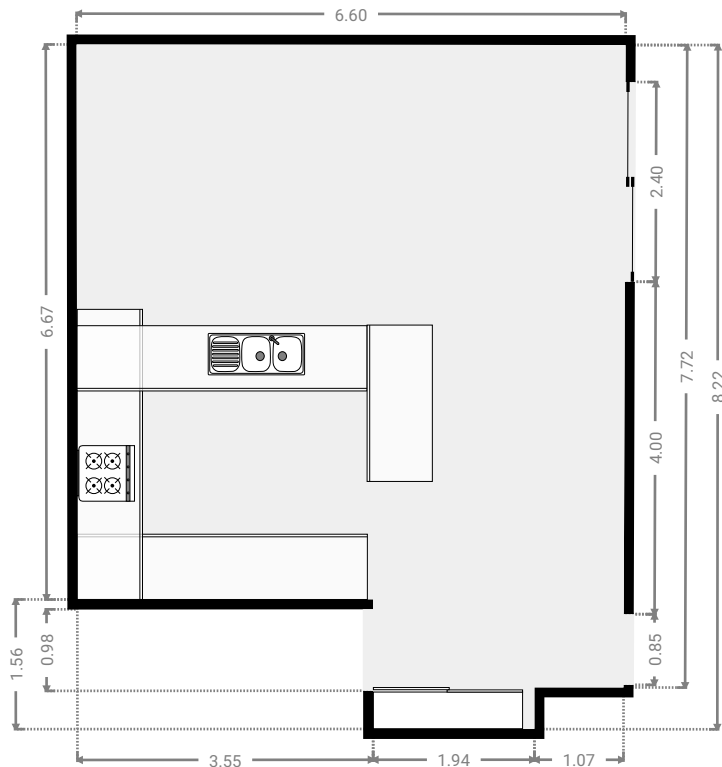
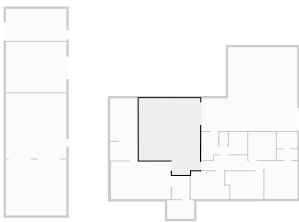

THIS FLOORPLAN IS PROVIDED WITHOUT WARRANTY OF ANY KIND. SENSOPIA DISCLAIMS ANY WARRANTY INCLUDING, WITHOUT LIMITATION, SATISFACTORY QUALITY OR ACCURACY OF DIMENSIONS.

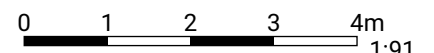

FLOORS: 1

▼ **Laundry Room**
Ground Floor

WIDTH: 1.81 m • LENGTH: 3.00 m
AREA: 5.07 m² • PERIMETER: 9.60 m

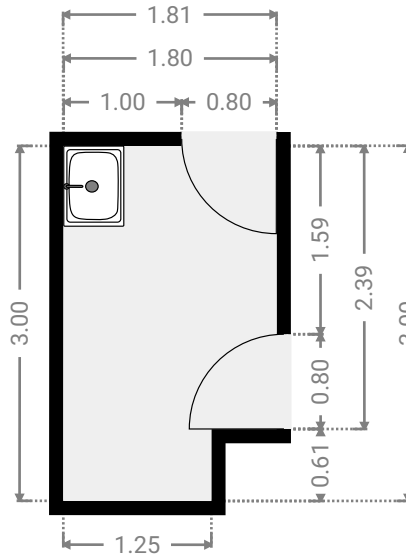
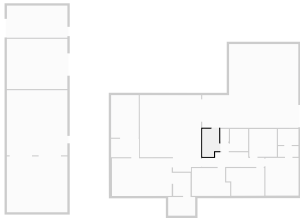

▼ **Living Room**
Ground Floor

WIDTH: 6.43 m • LENGTH: 4.05 m
AREA: 26.03 m² • PERIMETER: 20.95 m

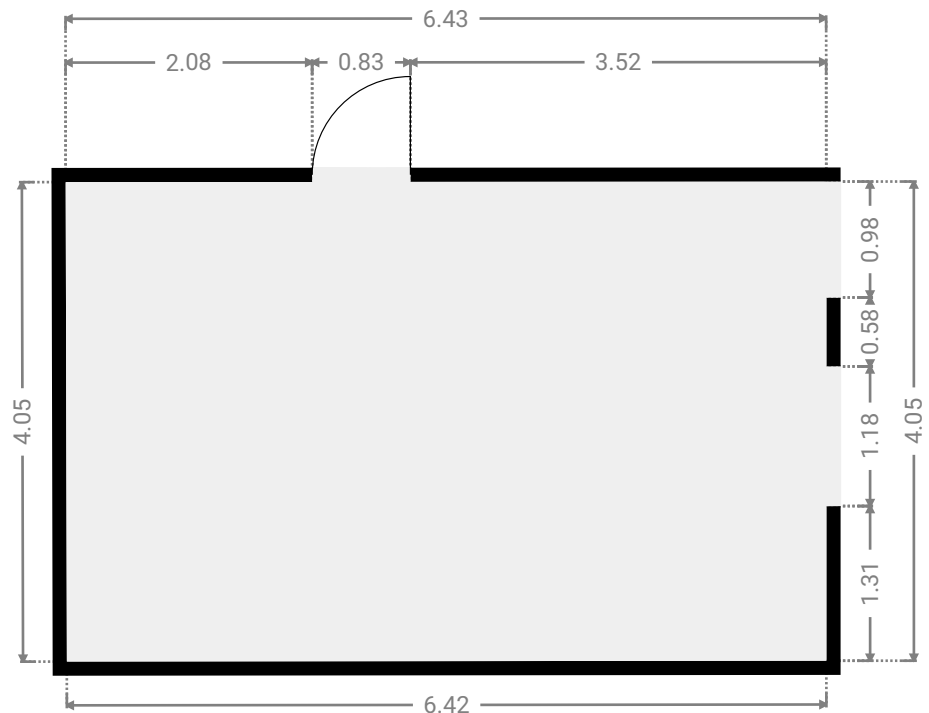

FLOORS: 1

▼ **Living Room**
Ground Floor

WIDTH: 2.98 m • LENGTH: 4.58 m
AREA: 13.61 m² • PERIMETER: 15.10 m

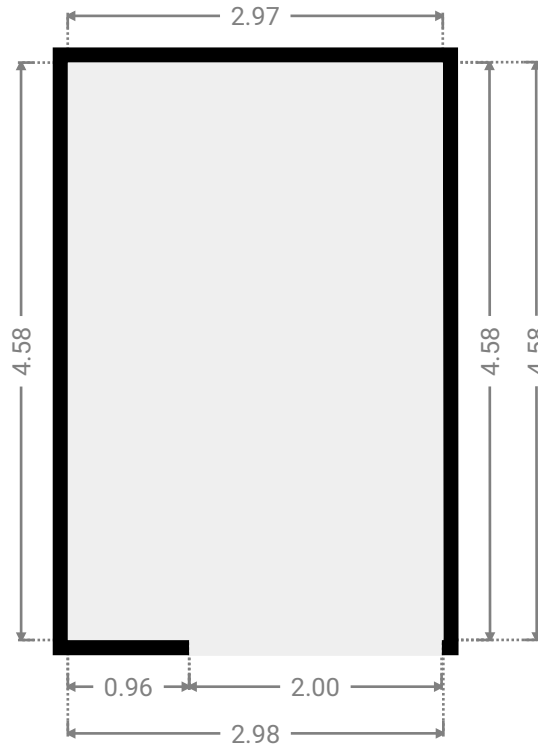
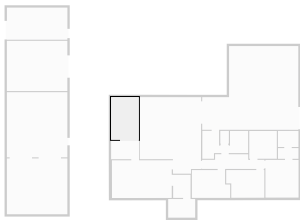

▼ **Other**
Ground Floor

WIDTH: 2.90 m • LENGTH: 2.00 m
AREA: 5.80 m² • PERIMETER: 9.80 m

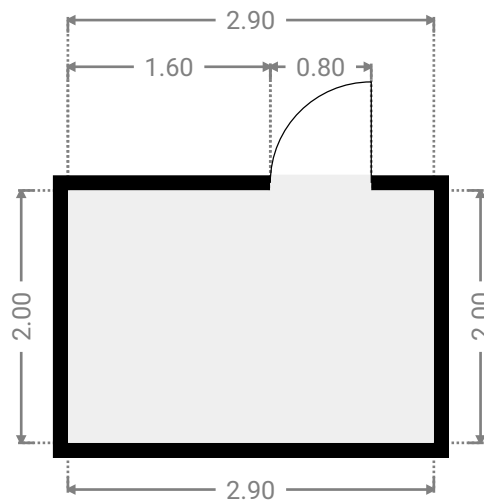
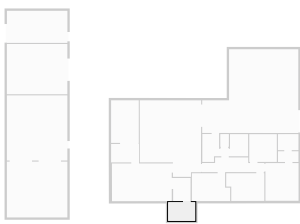

FLOORS: 1

▼ Other
Ground Floor

WIDTH: 6.50 m • LENGTH: 7.00 m
AREA: 45.50 m² • PERIMETER: 27.00 m

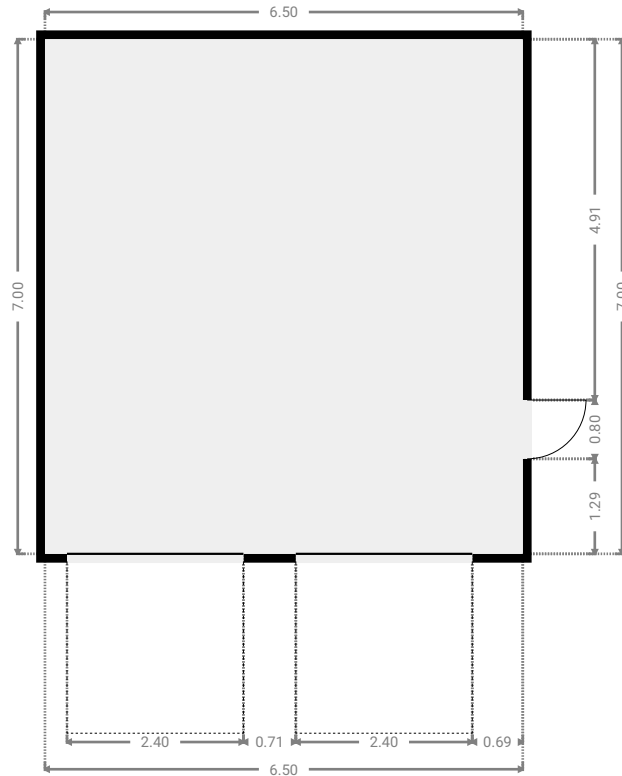
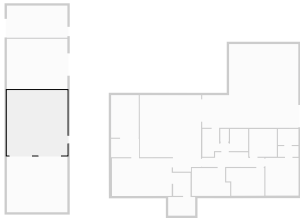

▼ Other
Ground Floor

WIDTH: 6.50 m • LENGTH: 5.40 m
AREA: 35.10 m² • PERIMETER: 23.80 m

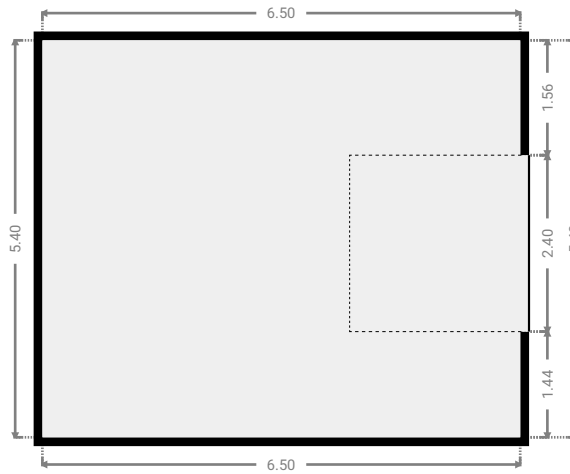

FLOORS: 1

▼ Other
Ground Floor

WIDTH: 6.50 m • LENGTH: 3.45 m
AREA: 22.43 m² • PERIMETER: 19.90 m

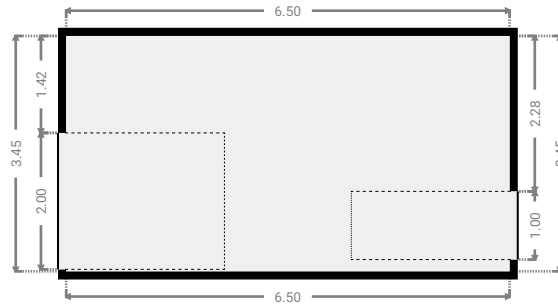

▼ Other
Ground Floor

WIDTH: 10.33 m • LENGTH: 9.00 m
AREA: 77.06 m² • PERIMETER: 38.64 m

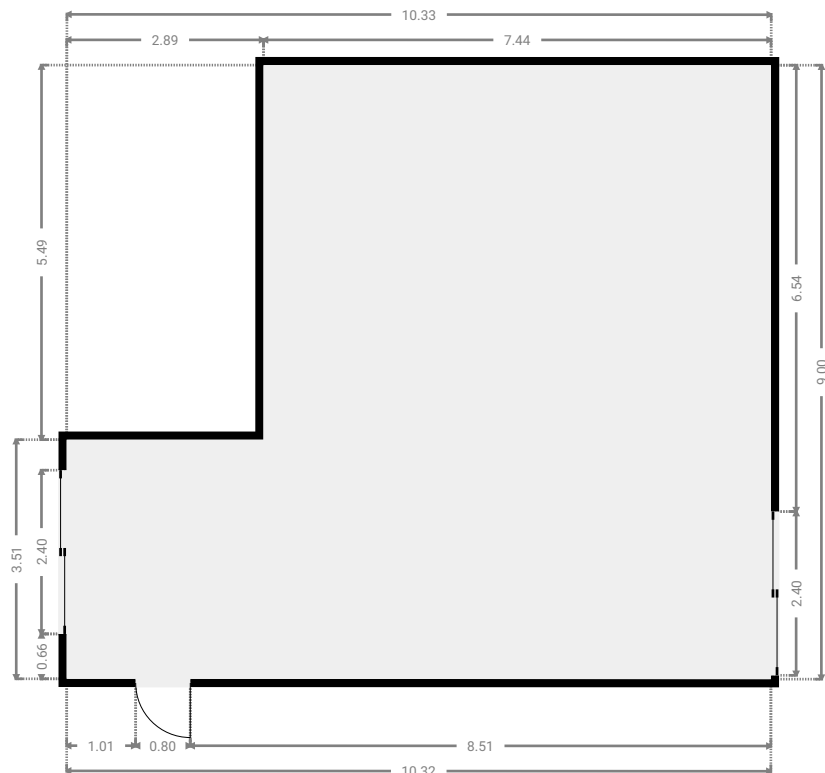
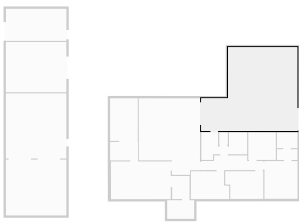

FLOORS: 1

▼ **Study**
Ground Floor

WIDTH: 3.00 m • LENGTH: 1.98 m
AREA: 5.94 m² • PERIMETER: 9.96 m

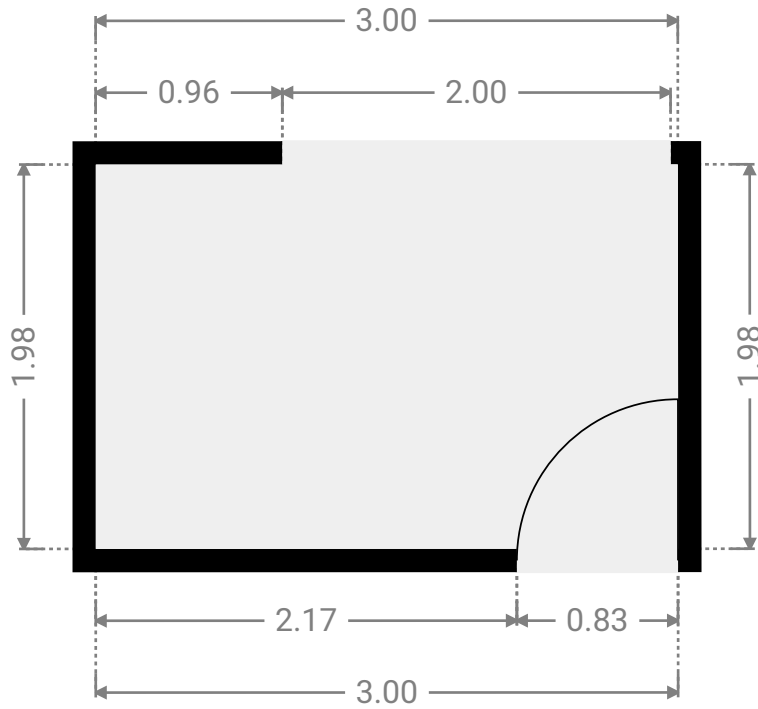
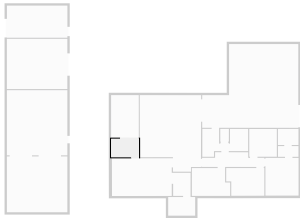

▼ **Toilet**
Ground Floor

WIDTH: 0.92 m • LENGTH: 1.37 m
AREA: 1.26 m² • PERIMETER: 4.57 m

