

96 North Street

SUBMITTED BY
Ray White Rockhampton Casey
stockers@cqoz.com

CREATED ON
2022-04-19

Floors
2

▼ Ground Floor

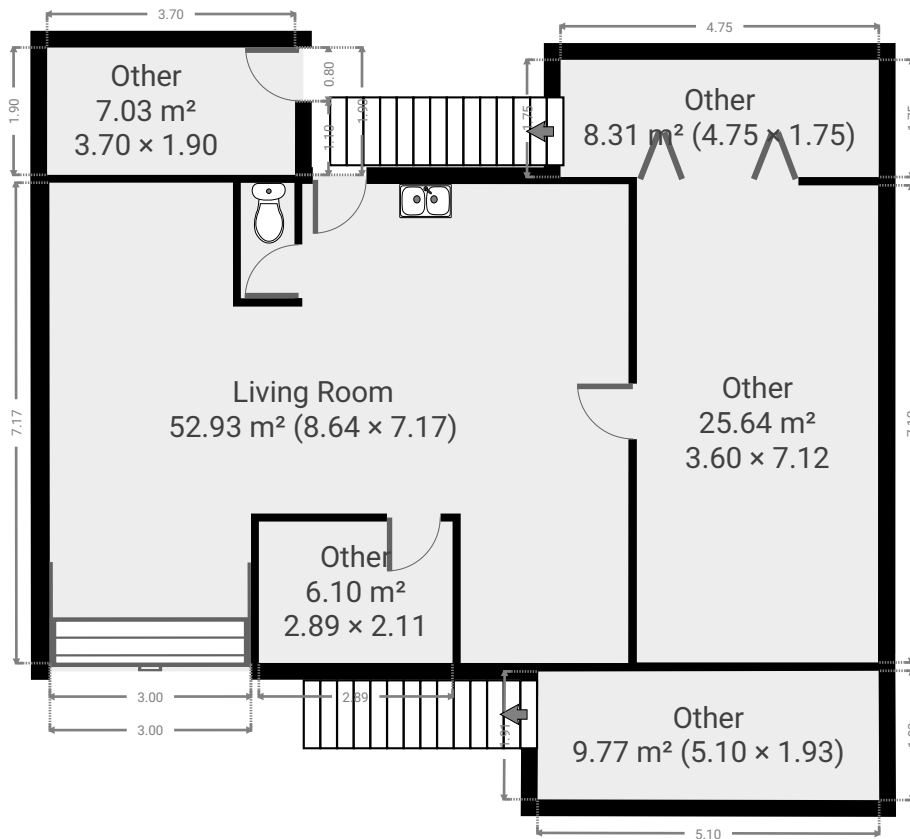
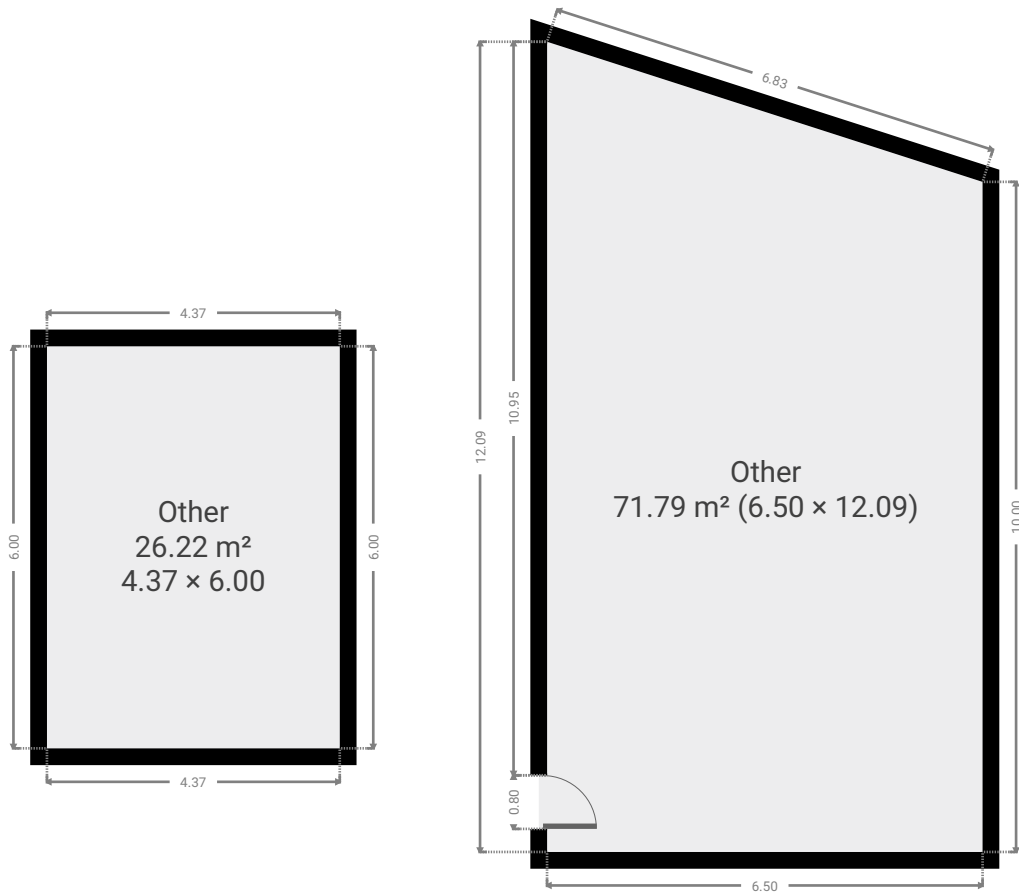

▼ Other
Ground Floor

WIDTH: 3.60 m • LENGTH: 7.12 m
AREA: 25.64 m² • PERIMETER: 21.44 m

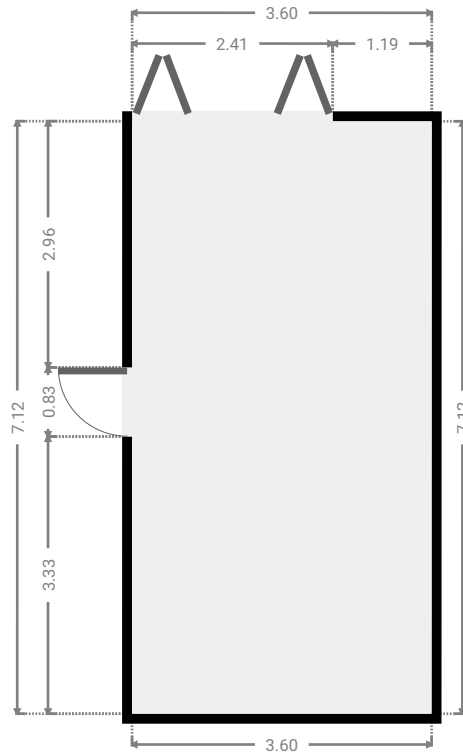
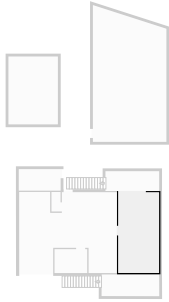

▼ Living Room
Ground Floor

WIDTH: 8.63 m • LENGTH: 7.17 m
AREA: 52.93 m² • PERIMETER: 39.73 m

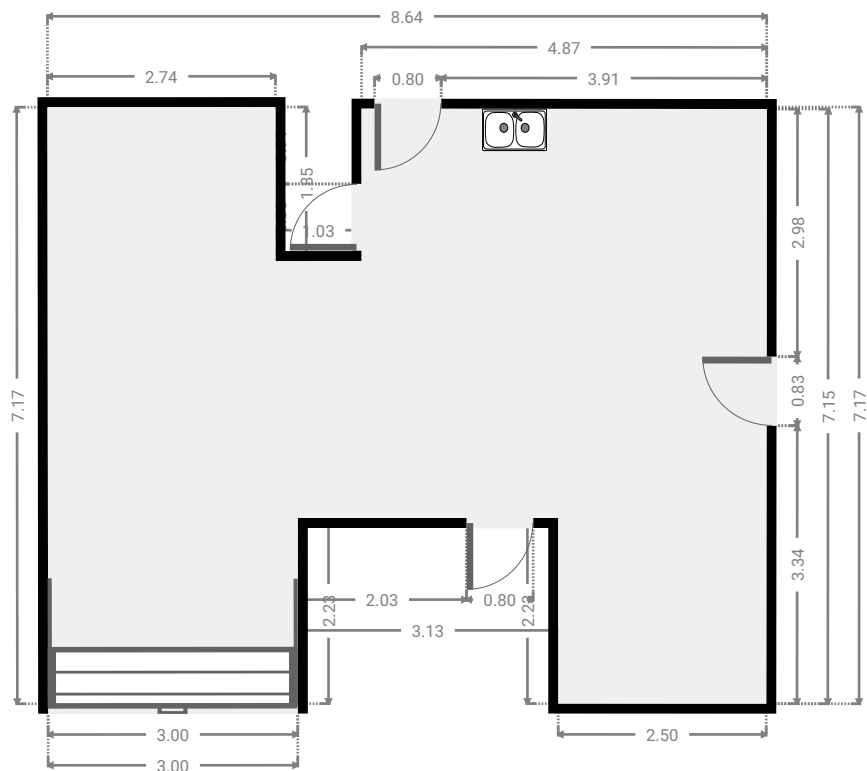
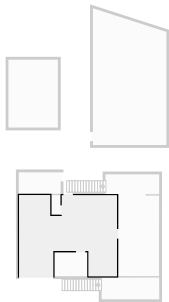

▼ **Other**
Ground Floor

WIDTH: 2.89 m • LENGTH: 2.11 m
AREA: 6.10 m² • PERIMETER: 10.00 m

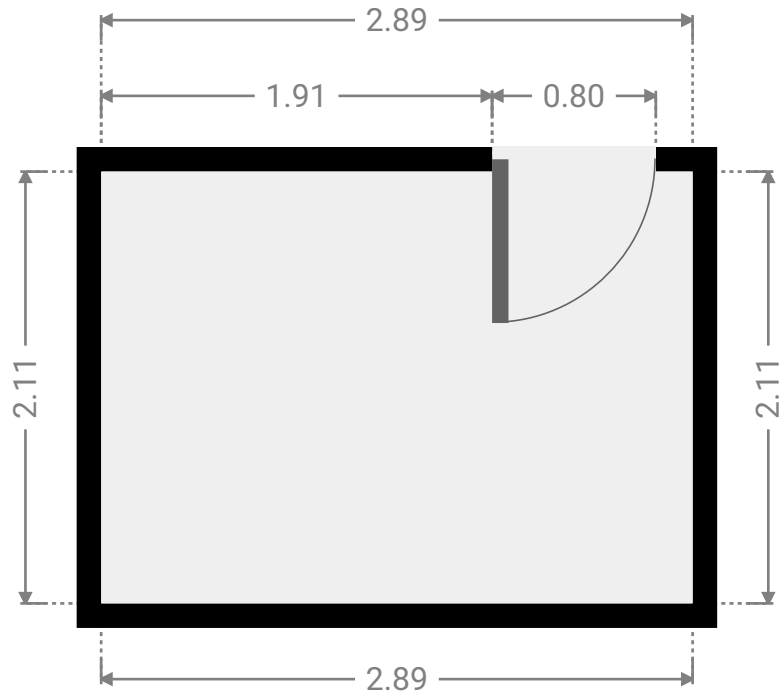
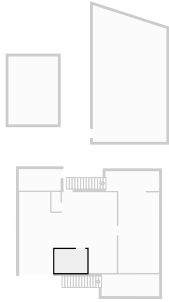

▼ **Vestibule**
Ground Floor

WIDTH: 0.78 m • LENGTH: 1.71 m
AREA: 1.38 m² • PERIMETER: 5.04 m

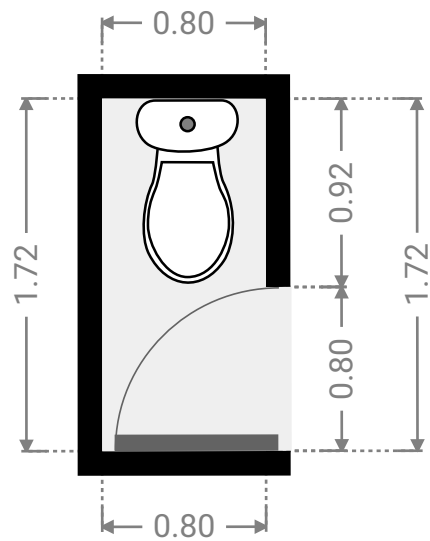
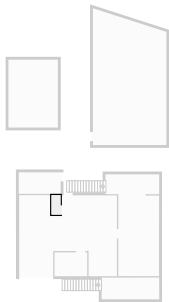

▼ Other
Ground Floor

WIDTH: 4.75 m • LENGTH: 1.75 m
AREA: 8.31 m² • PERIMETER: 13.00 m

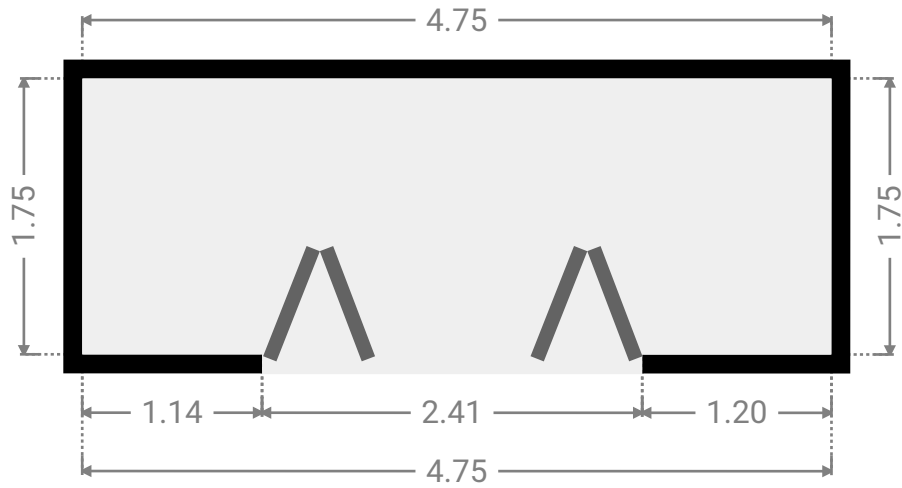
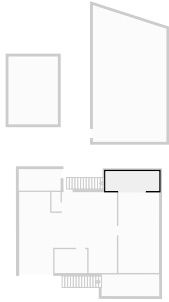

▼ Other
Ground Floor

WIDTH: 3.70 m • LENGTH: 1.90 m
AREA: 7.03 m² • PERIMETER: 11.20 m

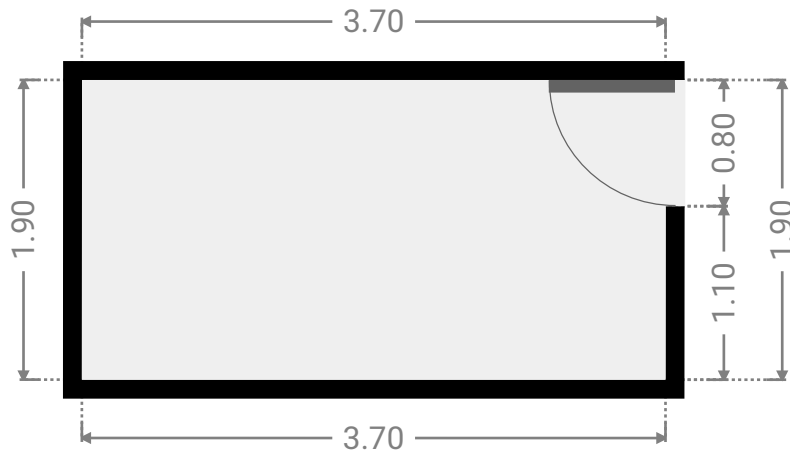
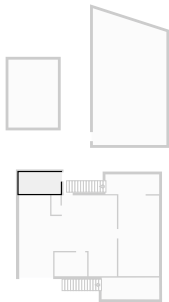

▼ Other
Ground Floor

WIDTH: 4.37 m • LENGTH: 6.00 m
AREA: 26.22 m² • PERIMETER: 20.74 m

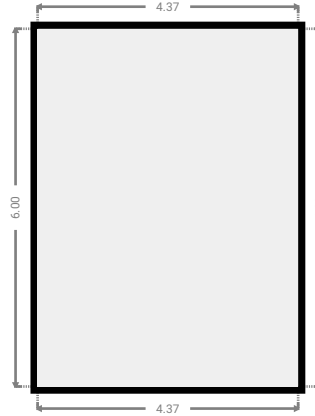
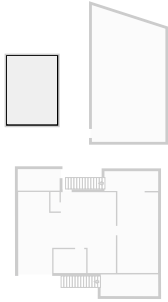

▼ Other
Ground Floor

WIDTH: 6.50 m • LENGTH: 12.09 m
AREA: 71.79 m² • PERIMETER: 35.42 m

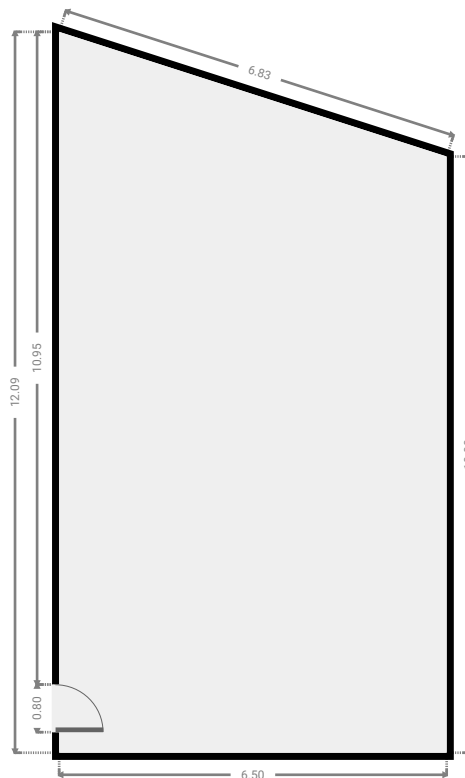
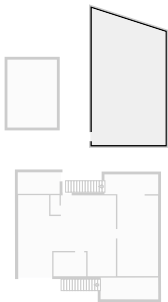

▼ Other
Ground Floor

WIDTH: 5.10 m • LENGTH: 1.93 m
AREA: 9.77 m² • PERIMETER: 14.02 m

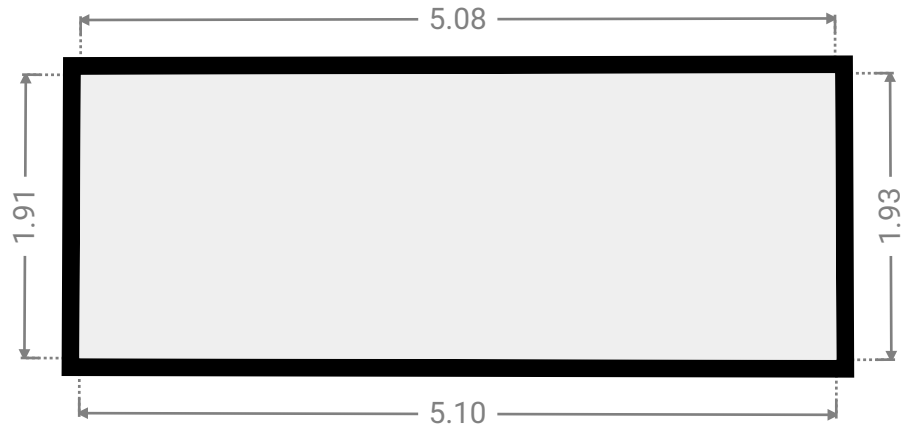
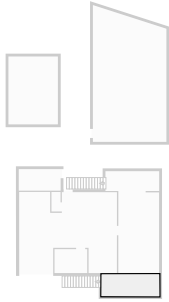

▼ 1st Floor

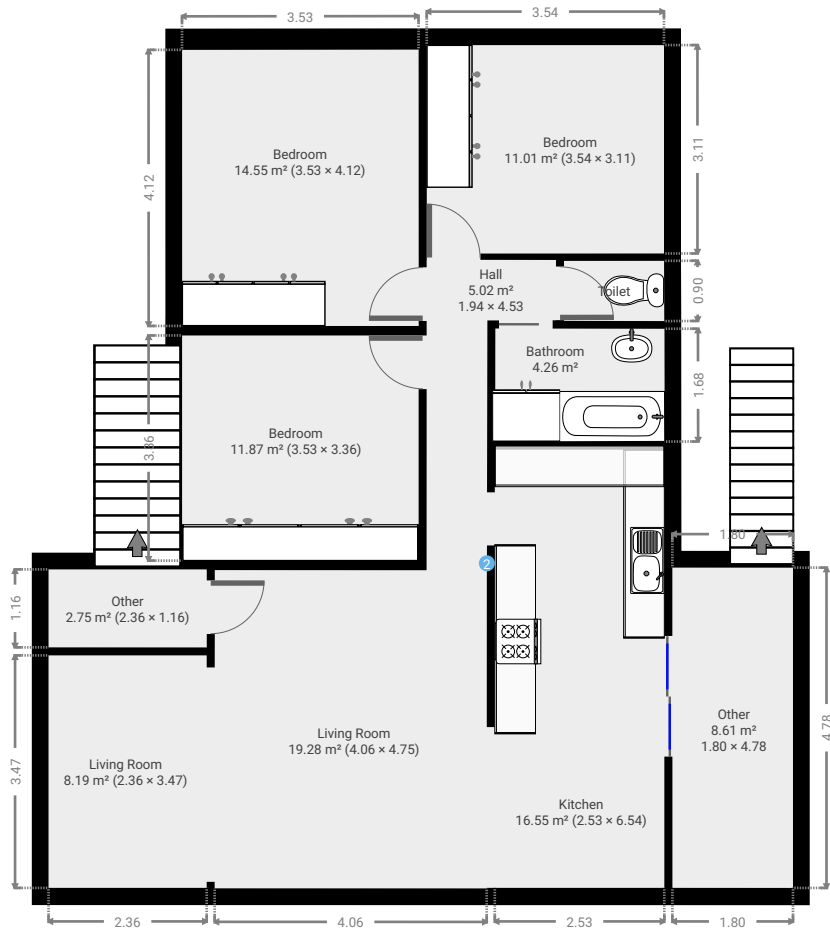

▼ Living Room
1st Floor

WIDTH: 3.47 m • LENGTH: 2.36 m
AREA: 8.19 m² • PERIMETER: 11.66 m

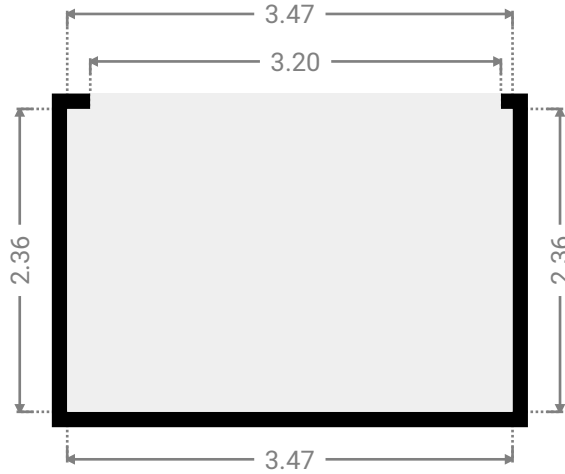
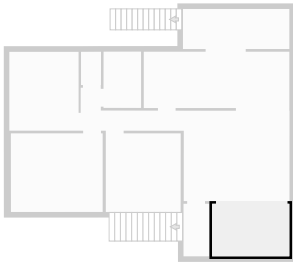

▼ Living Room
1st Floor

WIDTH: 4.75 m • LENGTH: 4.06 m
AREA: 19.28 m² • PERIMETER: 17.62 m

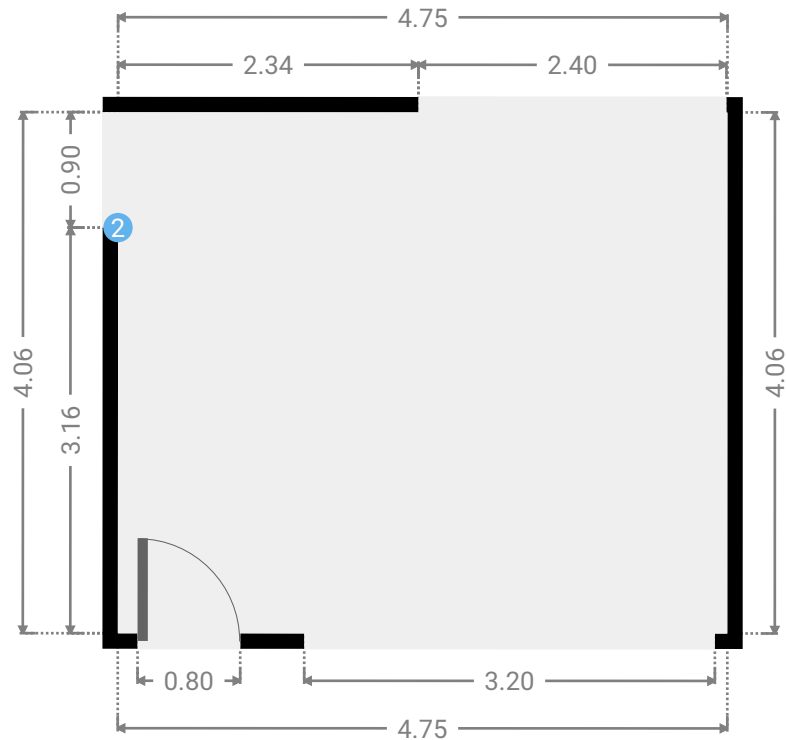
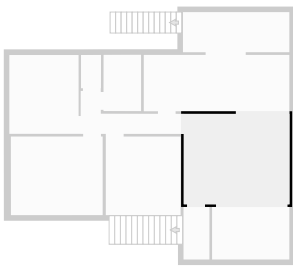

▼ **Kitchen**
1st Floor

WIDTH: 6.54 m • LENGTH: 2.53 m
AREA: 16.55 m² • PERIMETER: 18.14 m

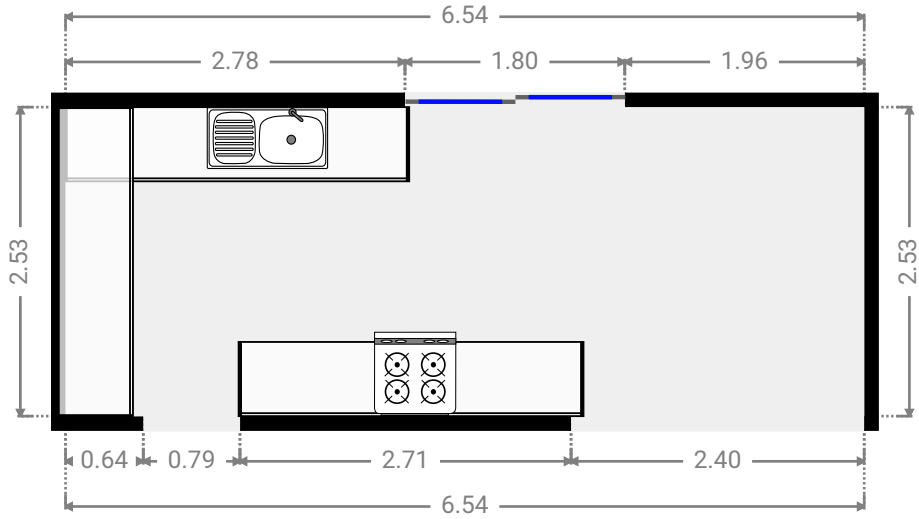
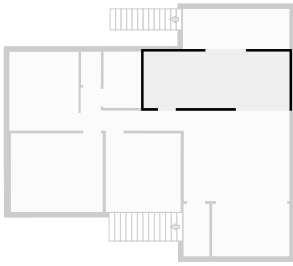

▼ **Other**
1st Floor

WIDTH: 4.78 m • LENGTH: 1.80 m
AREA: 8.61 m² • PERIMETER: 13.16 m

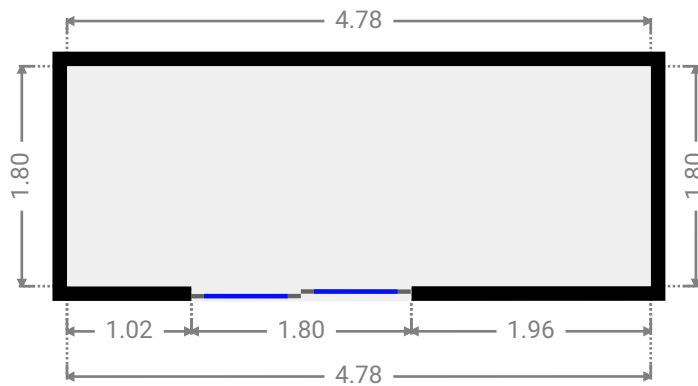
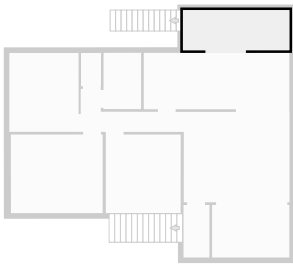

▼ **Hall**
1st Floor

WIDTH: 4.53 m • LENGTH: 1.94 m
AREA: 5.02 m² • PERIMETER: 12.91 m

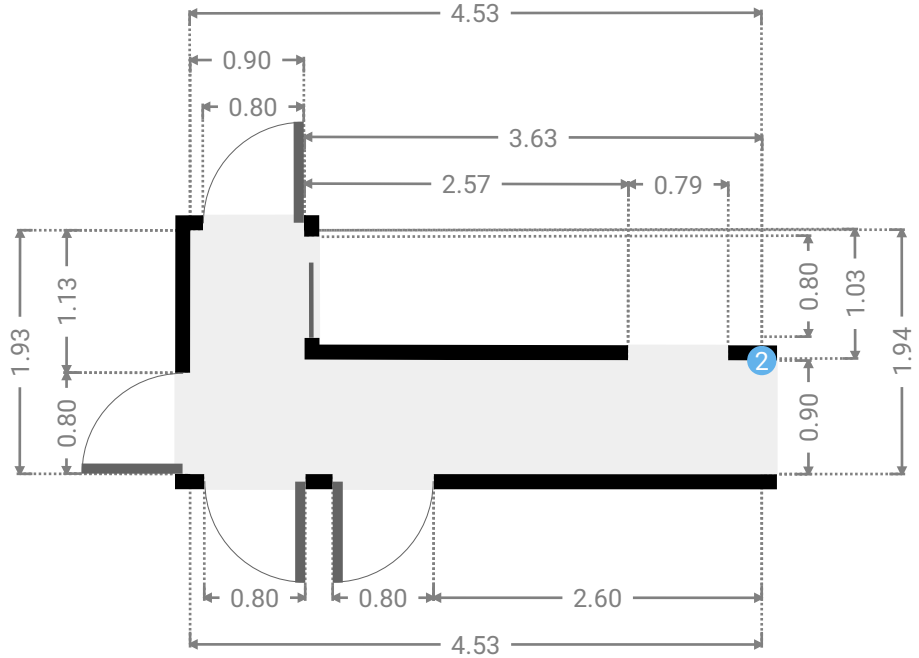
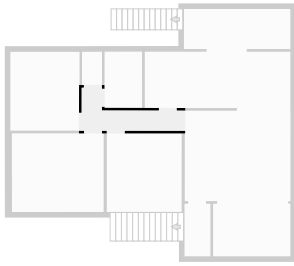

▼ **Hall/1st Floor**

2 OPENING

Height
0.00 m



▼ **Bedroom**
1st Floor

WIDTH: 3.36 m • LENGTH: 3.53 m
AREA: 11.87 m² • PERIMETER: 13.78 m

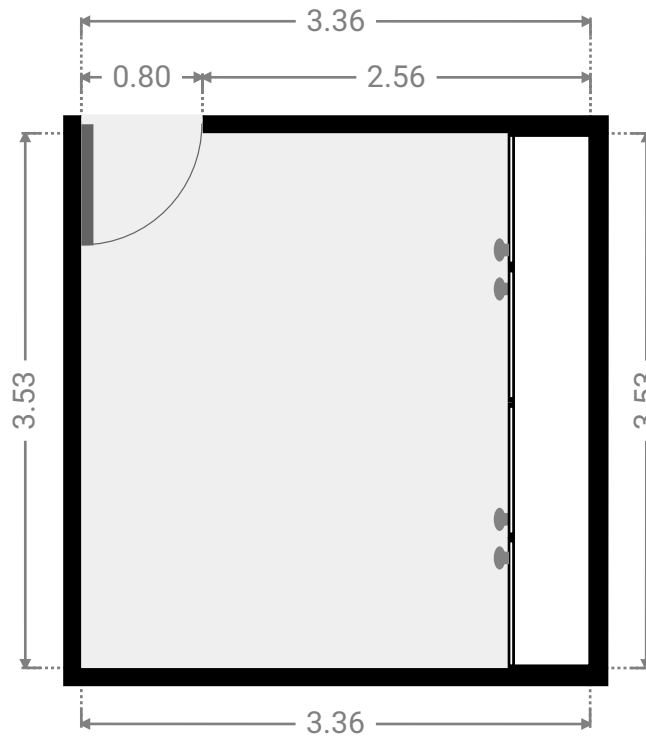
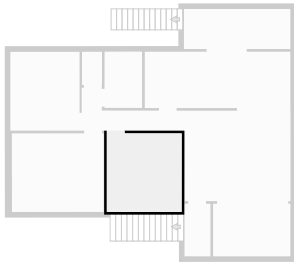

▼ **Bedroom**
1st Floor

WIDTH: 4.12 m • LENGTH: 3.53 m
AREA: 14.55 m² • PERIMETER: 15.30 m

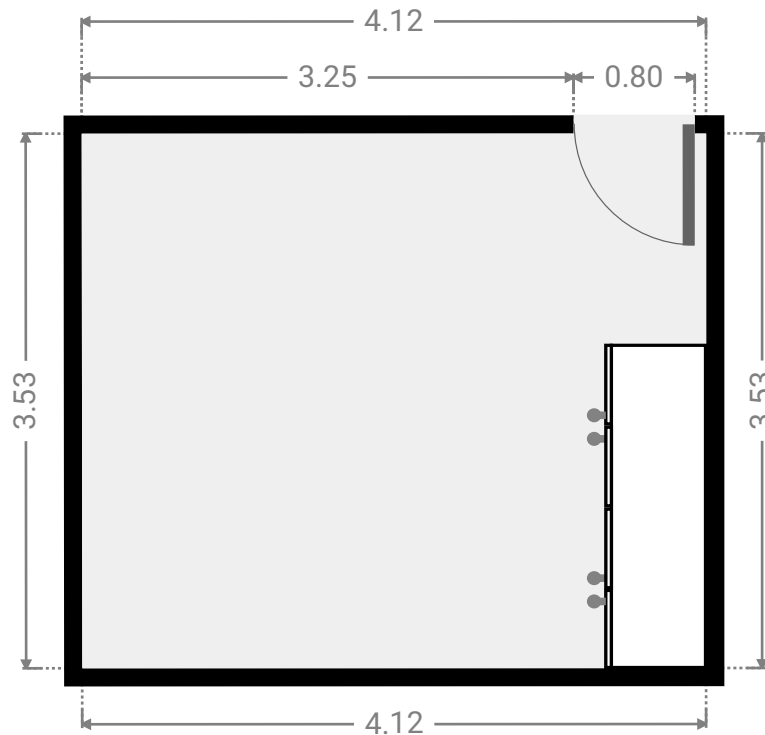
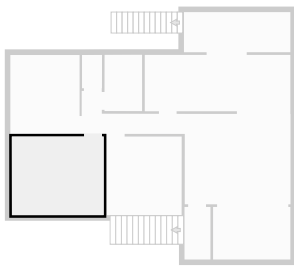

▼ **Bedroom**
1st Floor

WIDTH: 3.11 m • LENGTH: 3.54 m
AREA: 11.01 m² • PERIMETER: 13.30 m

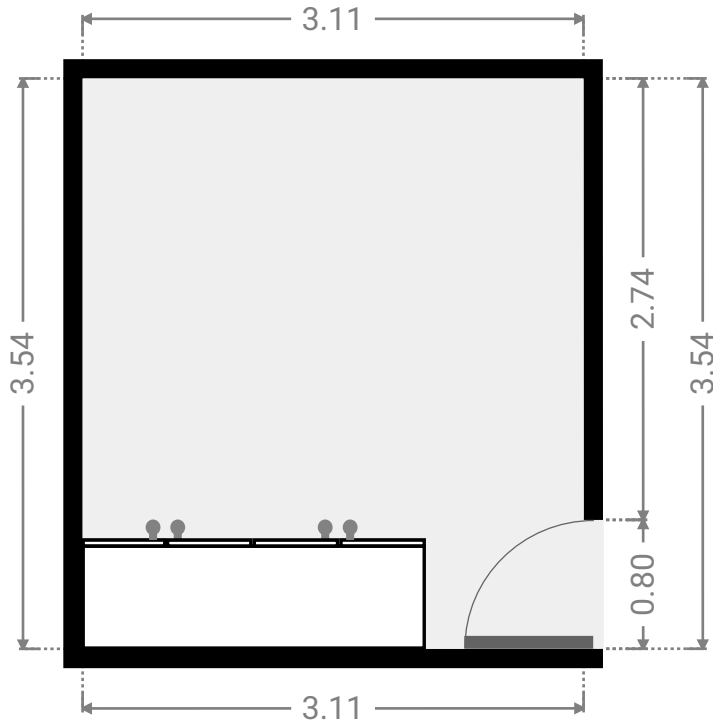
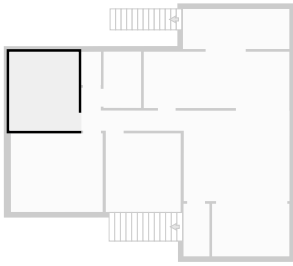

▼ **Toilet**
1st Floor

WIDTH: 0.90 m • LENGTH: 1.49 m
AREA: 1.34 m² • PERIMETER: 4.78 m

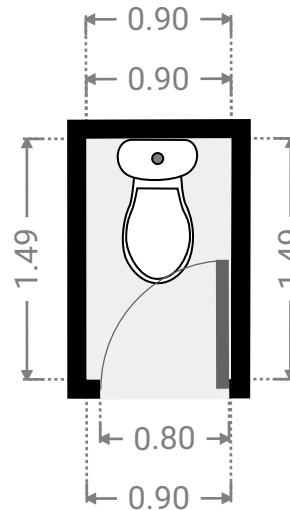
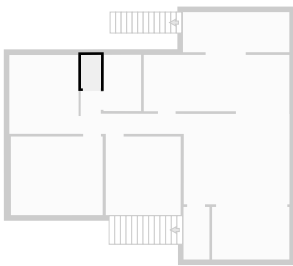

▼ **Bathroom**
1st Floor

WIDTH: 1.69 m • LENGTH: 2.53 m
AREA: 4.26 m² • PERIMETER: 8.43 m

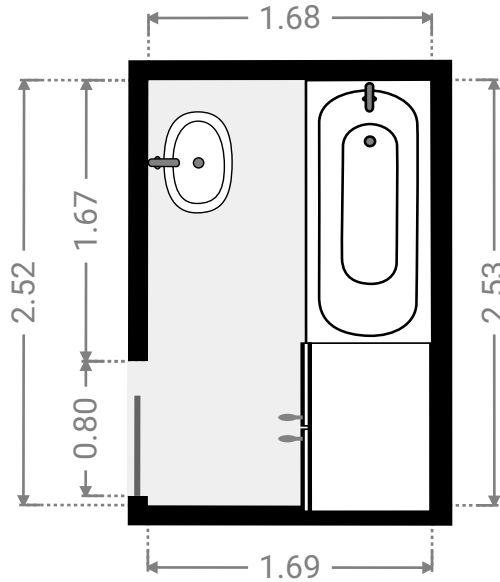
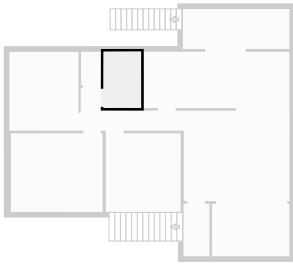

▼ **Other**
1st Floor

WIDTH: 1.16 m • LENGTH: 2.36 m
AREA: 2.75 m² • PERIMETER: 7.05 m

