

91 Curran Street

SUBMITTED BY
Ray White Rockhampton Casey
stockers@cqoz.com

CREATED ON
2022-02-07

Floors
2

▼ Ground Floor

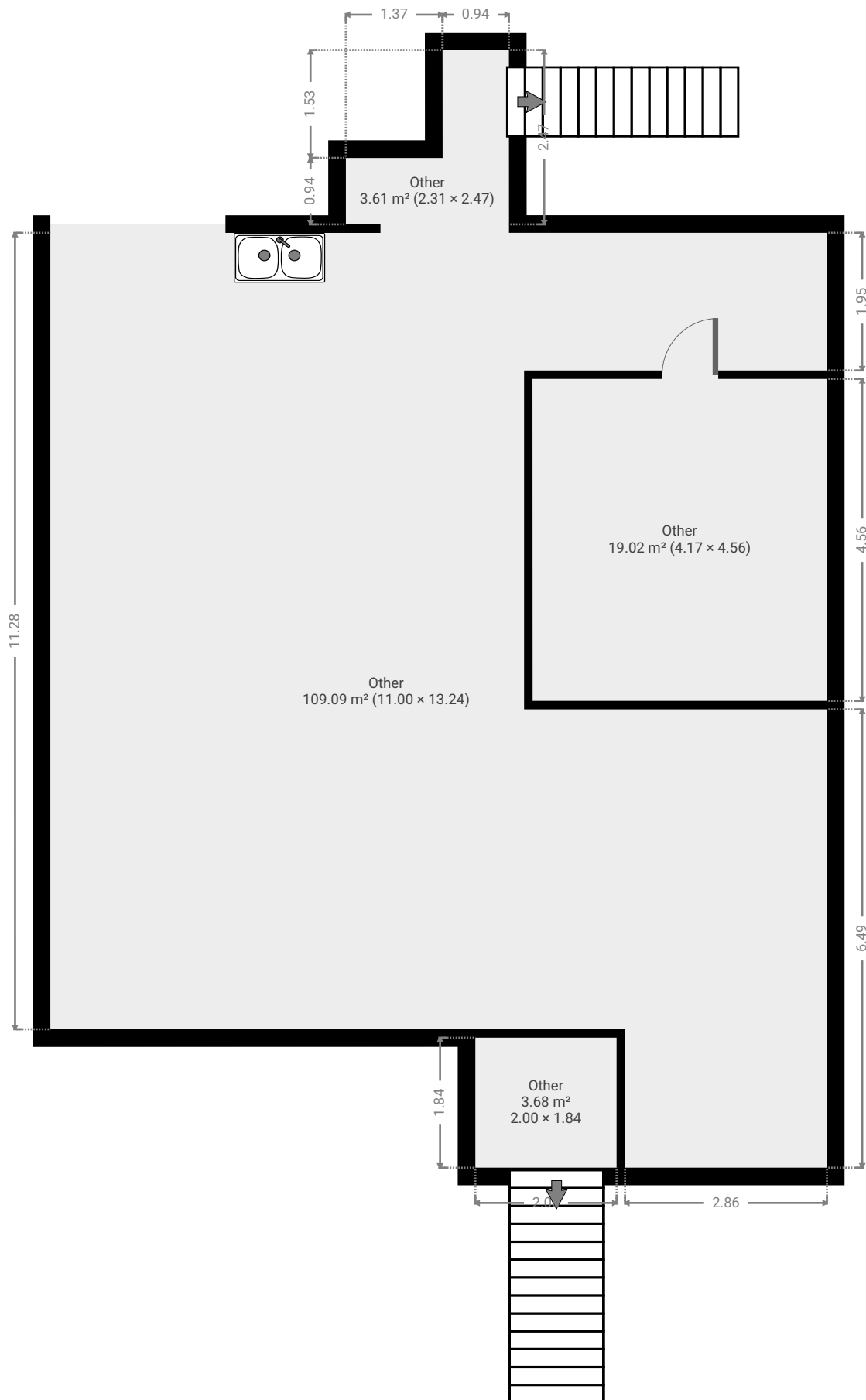

▼ Other
Ground Floor

WIDTH: 11.00 m • LENGTH: 13.24 m
AREA: 109.09 m² • PERIMETER: 57.06 m

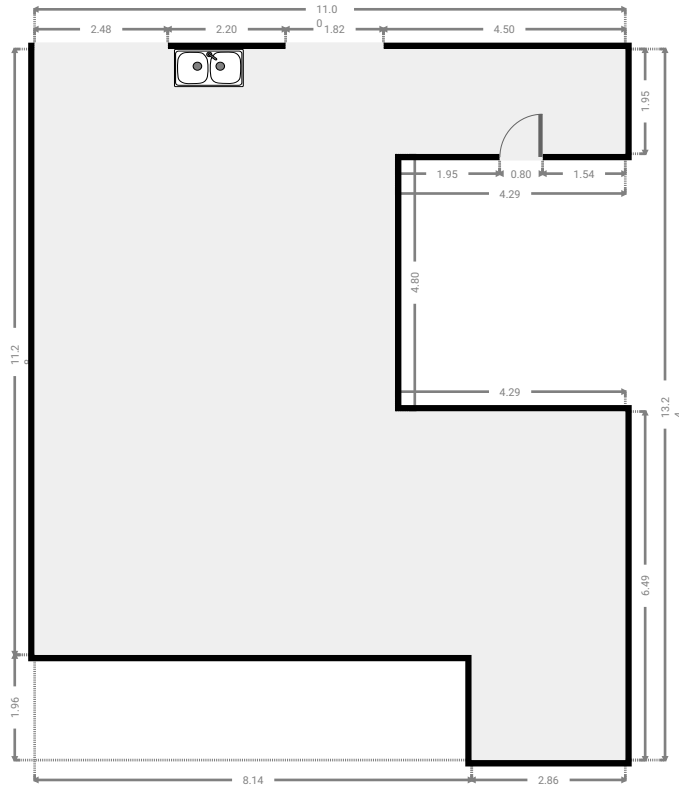
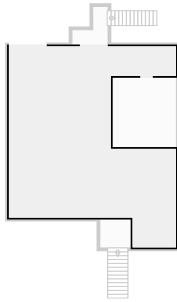

▼ Other
Ground Floor

WIDTH: 4.17 m • LENGTH: 4.56 m
AREA: 19.02 m² • PERIMETER: 17.46 m

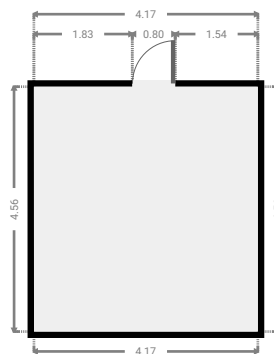
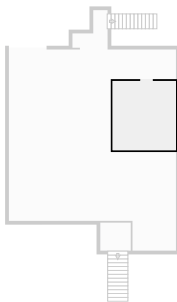

▼ Other
Ground Floor

WIDTH: 2.31 m • LENGTH: 2.47 m
AREA: 3.61 m² • PERIMETER: 9.56 m

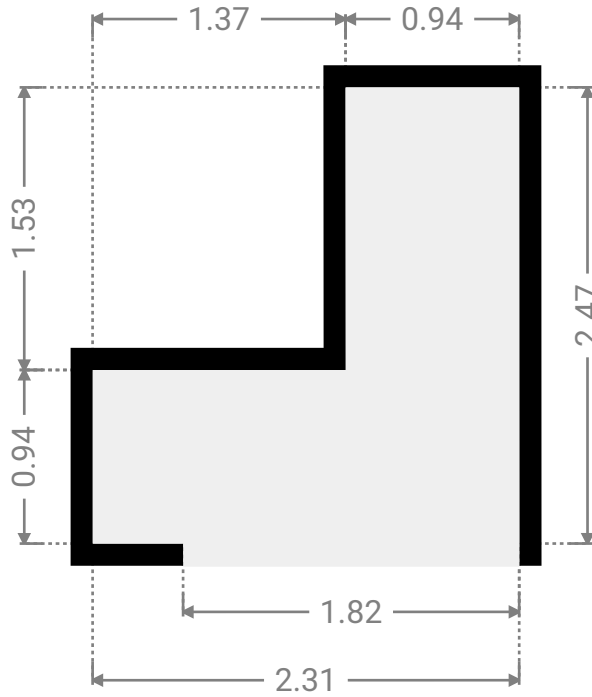
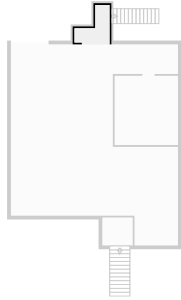

▼ Other
Ground Floor

WIDTH: 2.00 m • LENGTH: 1.84 m
AREA: 3.68 m² • PERIMETER: 7.68 m

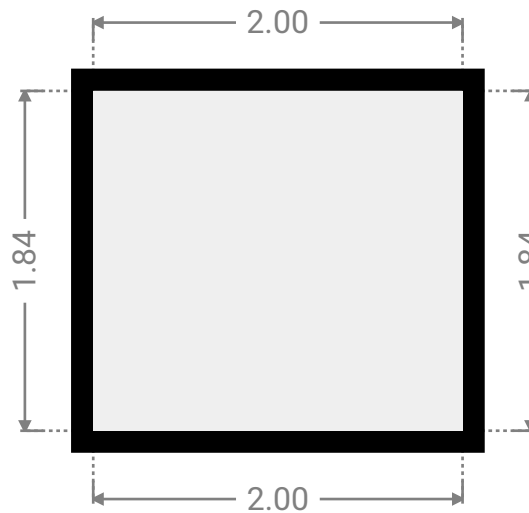
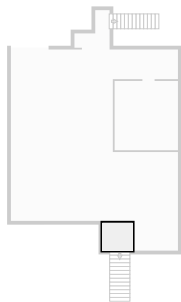

▼ 1st Floor

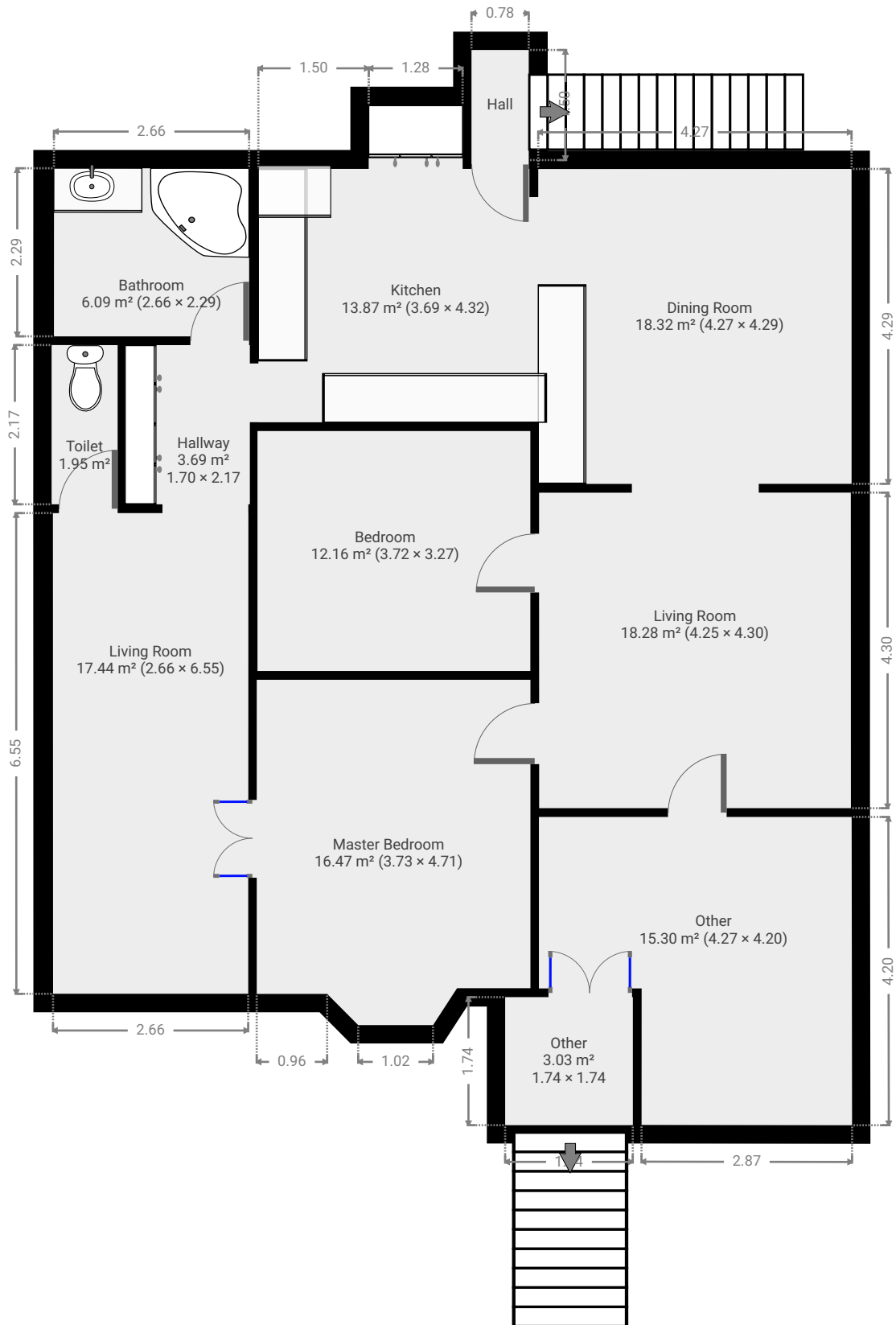

▼ **Living Room**
1st Floor

WIDTH: 4.25 m • LENGTH: 4.30 m
AREA: 18.28 m² • PERIMETER: 17.10 m

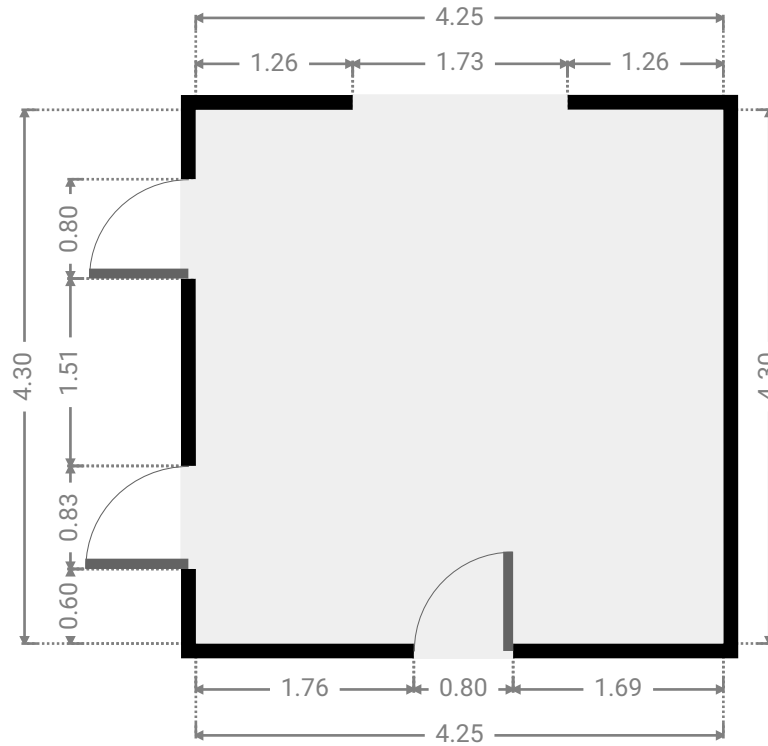
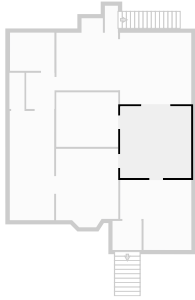

▼ **Master Bedroom**
1st Floor

WIDTH: 3.73 m • LENGTH: 4.71 m
AREA: 16.47 m² • PERIMETER: 16.39 m

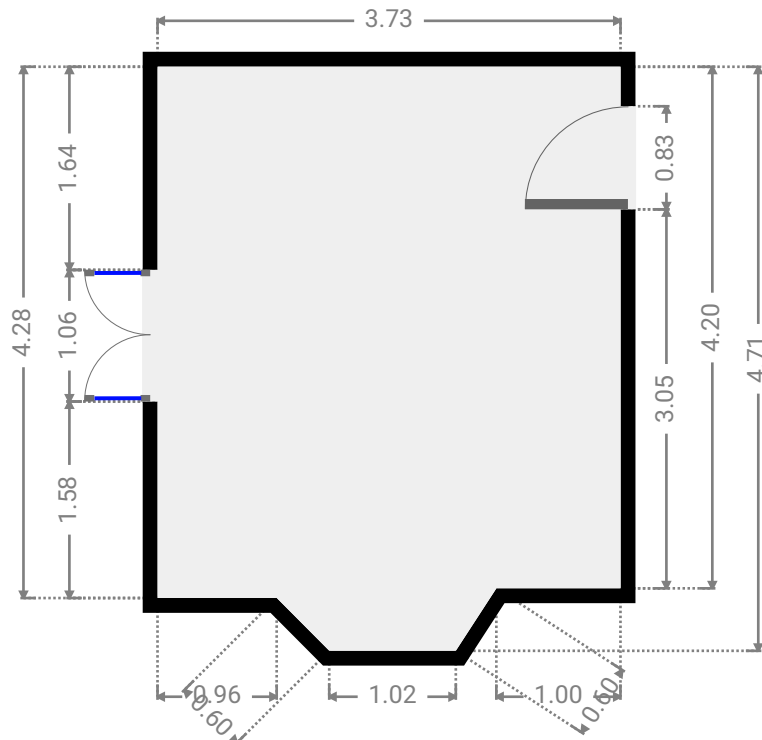
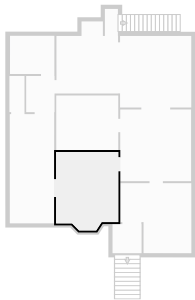

▼ Living Room
1st Floor

WIDTH: 2.66 m • LENGTH: 6.55 m
AREA: 17.44 m² • PERIMETER: 18.42 m

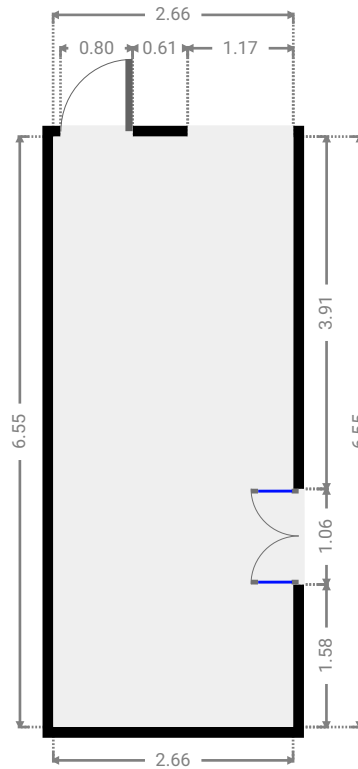
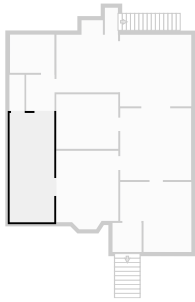

▼ Toilet
1st Floor

WIDTH: 0.90 m • LENGTH: 2.17 m
AREA: 1.95 m² • PERIMETER: 6.14 m

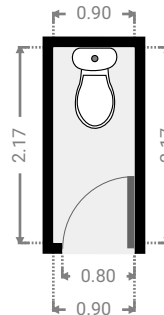
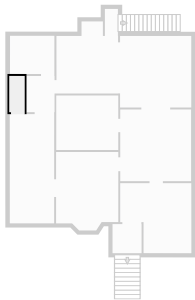

▼ **Hallway**
1st Floor

WIDTH: 1.70 m • LENGTH: 2.17 m
AREA: 3.69 m² • PERIMETER: 7.74 m

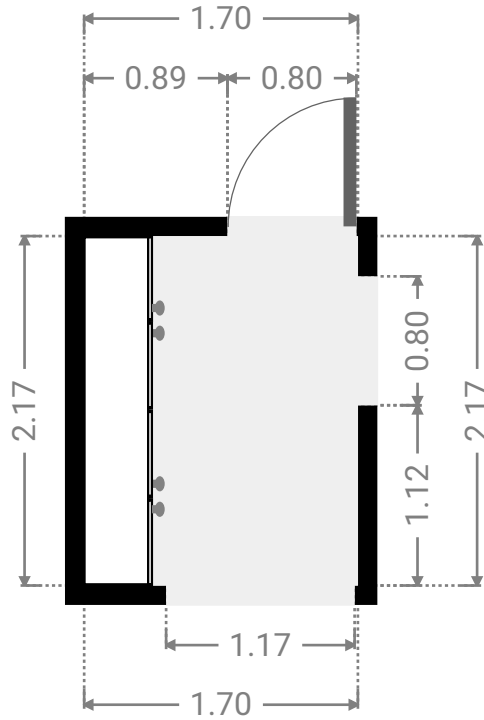
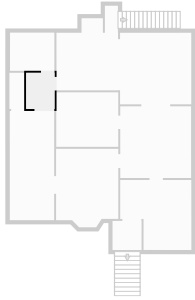

▼ **Bathroom**
1st Floor

WIDTH: 2.66 m • LENGTH: 2.29 m
AREA: 6.09 m² • PERIMETER: 9.90 m

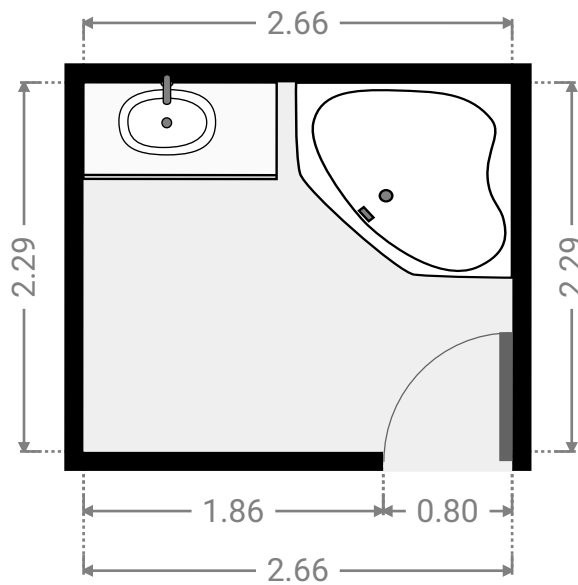
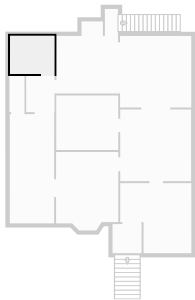

▼ **Bedroom**
1st Floor

WIDTH: 3.72 m • LENGTH: 3.27 m
AREA: 12.16 m² • PERIMETER: 13.98 m

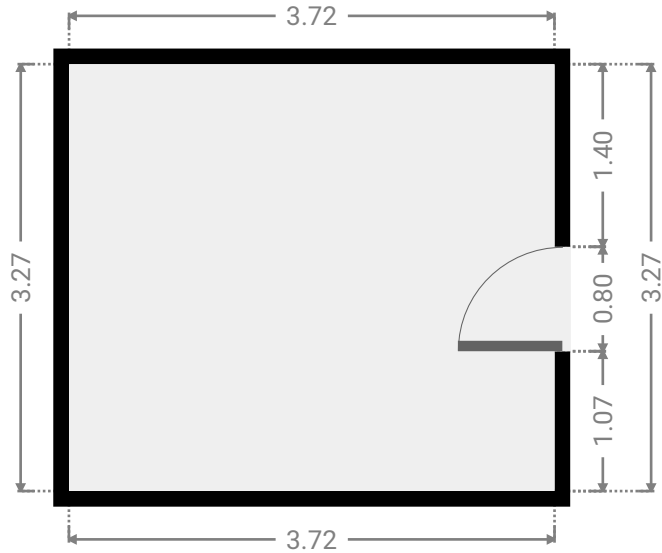
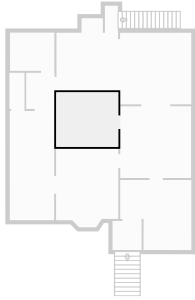

▼ **Dining Room**
1st Floor

WIDTH: 4.27 m • LENGTH: 4.29 m
AREA: 18.32 m² • PERIMETER: 17.12 m

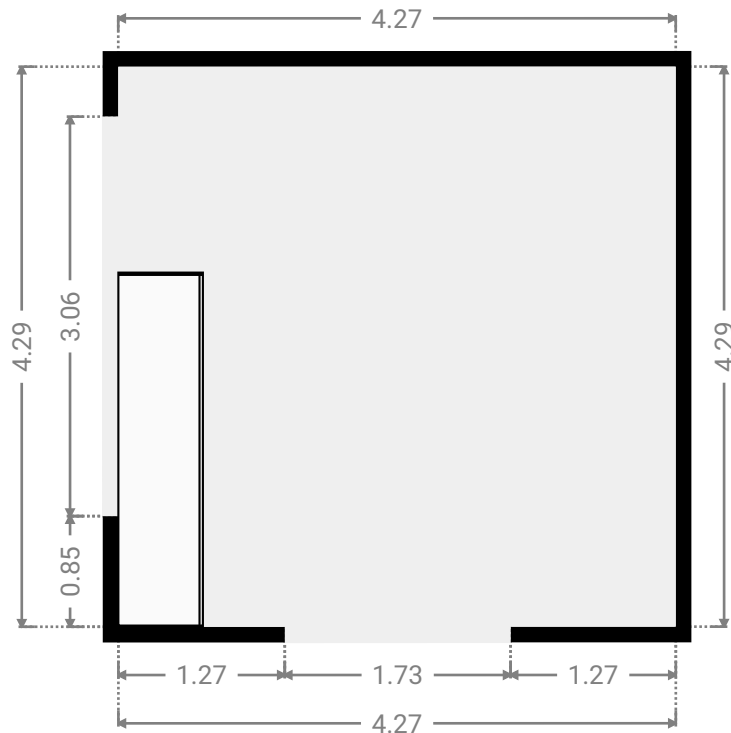
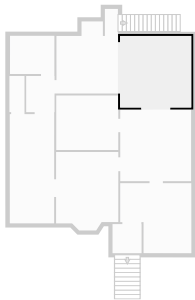

▼ Kitchen
1st Floor

WIDTH: 3.69 m • LENGTH: 4.32 m
AREA: 13.87 m² • PERIMETER: 16.03 m

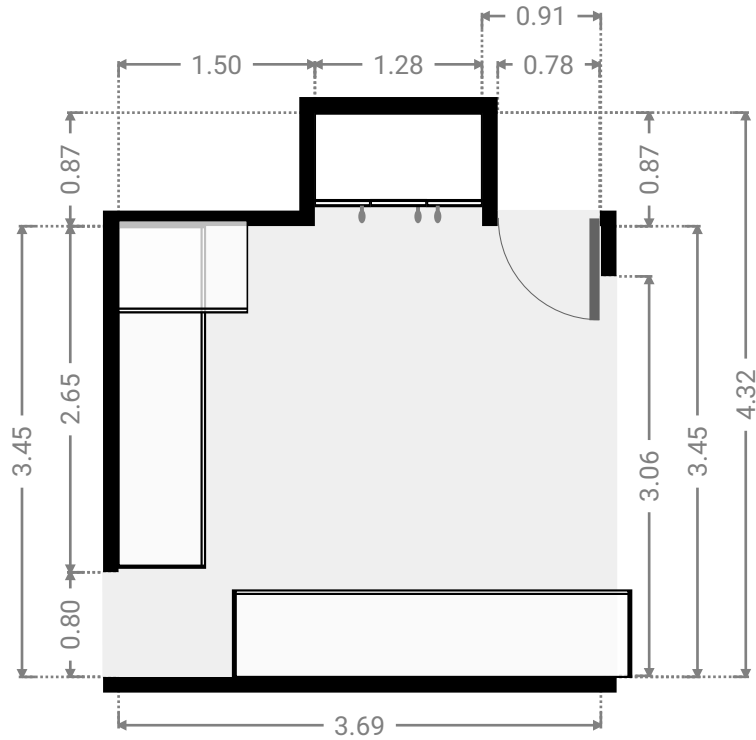
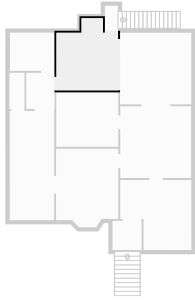

▼ Hall
1st Floor

WIDTH: 0.78 m • LENGTH: 1.50 m
AREA: 1.17 m² • PERIMETER: 4.56 m

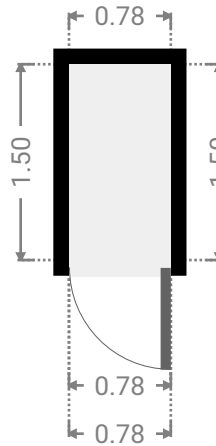
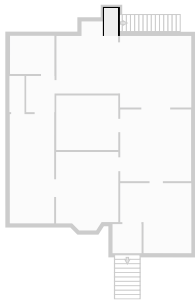

▼ Other
1st Floor

WIDTH: 4.27 m • LENGTH: 4.20 m
AREA: 15.30 m² • PERIMETER: 16.93 m

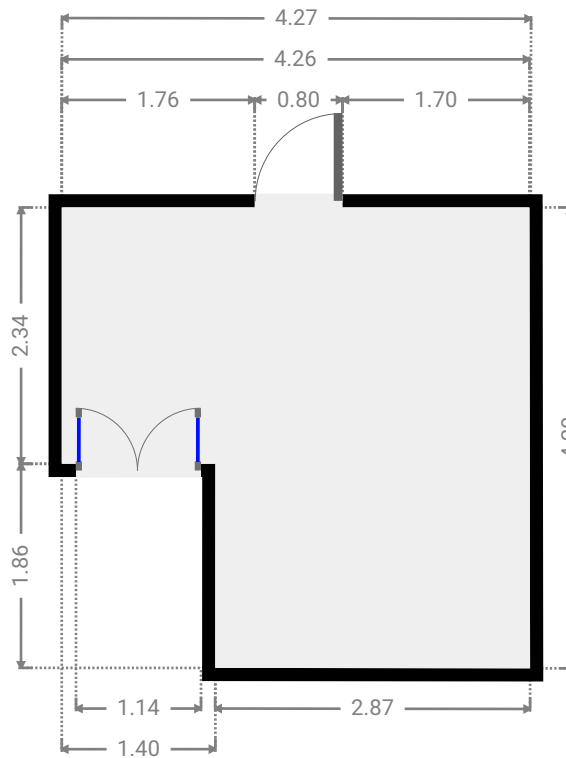
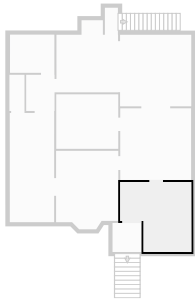

▼ Other
1st Floor

WIDTH: 1.74 m • LENGTH: 1.74 m
AREA: 3.03 m² • PERIMETER: 6.97 m

