

90 west street

SUBMITTED BY
Ray White Rockhampton Casey
stockers@cqoz.com

CREATED ON
2022-12-14

Floors
2

▼ Ground Floor

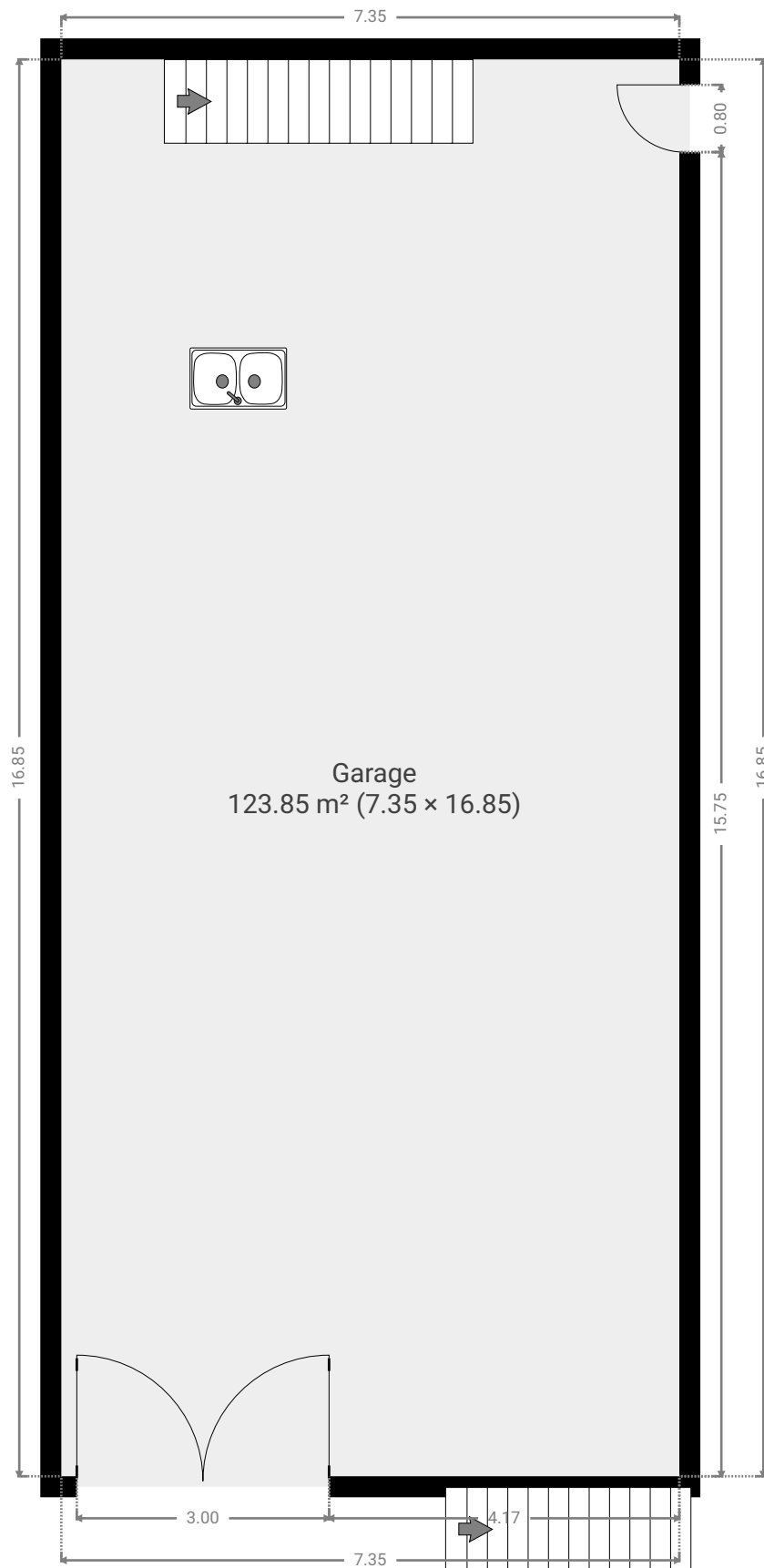

▼ Garage
Ground Floor

WIDTH: 7.35 m • LENGTH: 16.85 m
AREA: 123.85 m² • PERIMETER: 48.40 m

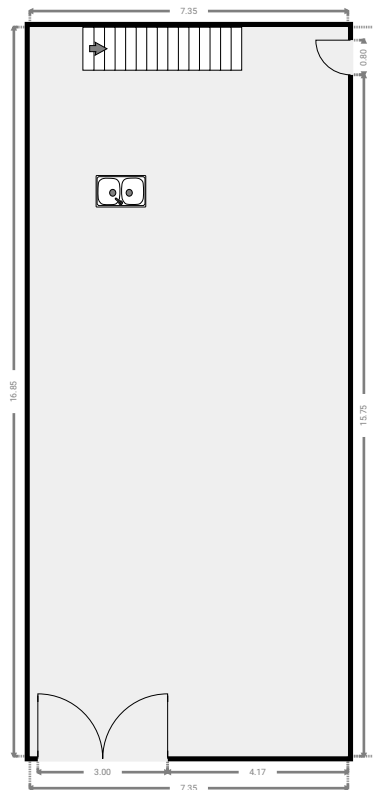

▼ 1st Floor

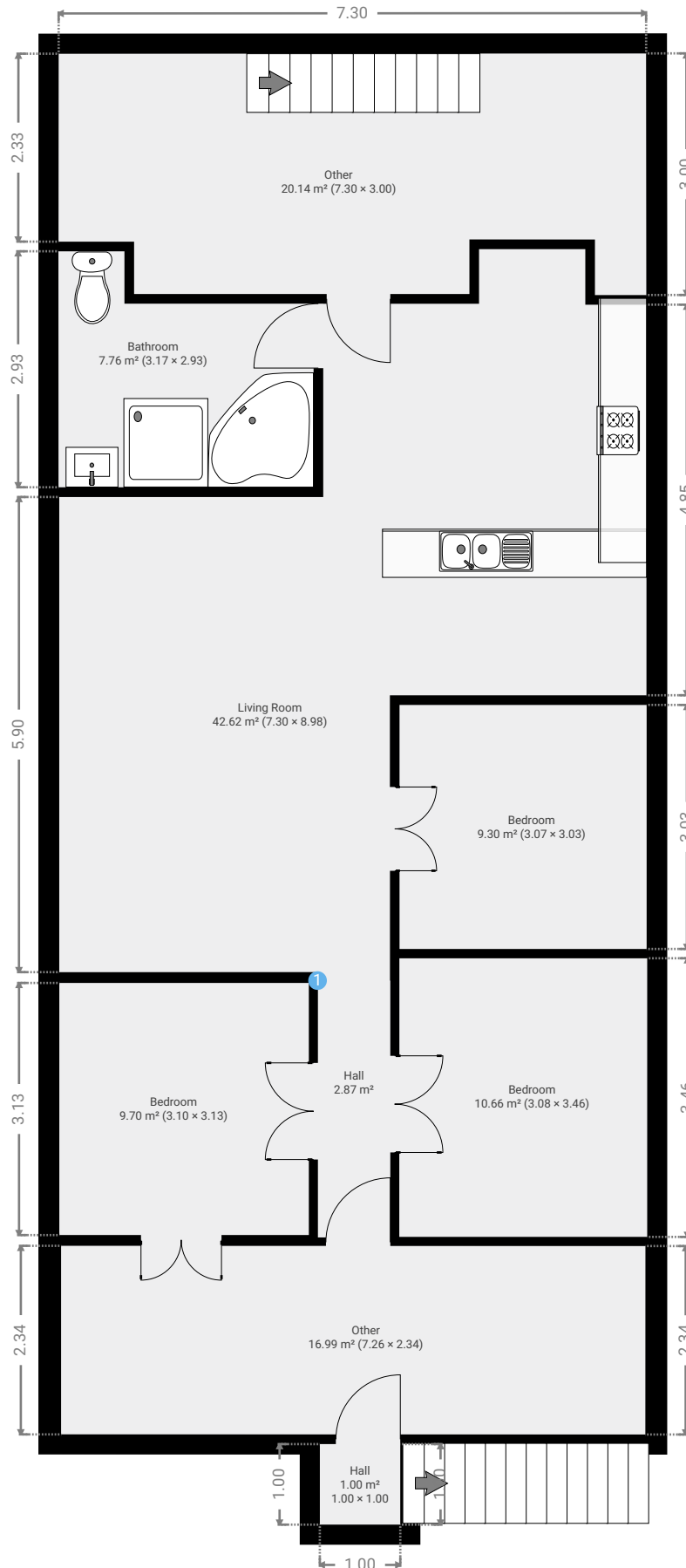

▼ **Bathroom**
1st Floor

WIDTH: 3.17 m • LENGTH: 2.93 m
AREA: 7.76 m² • PERIMETER: 12.20 m

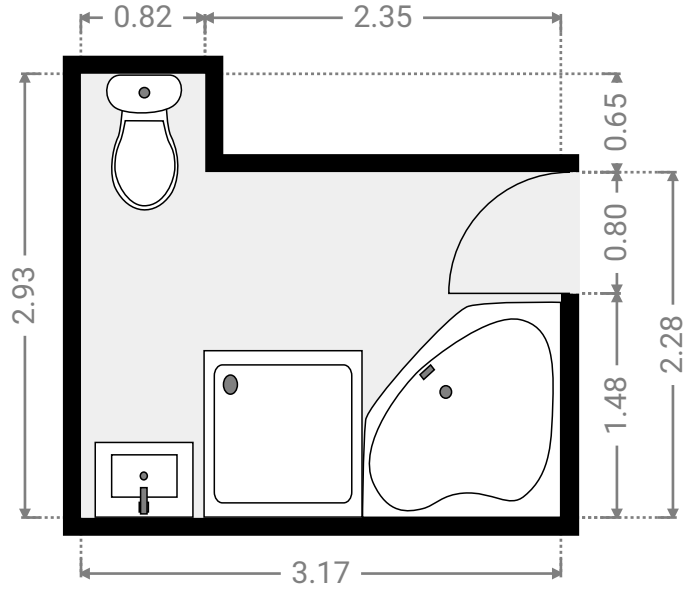
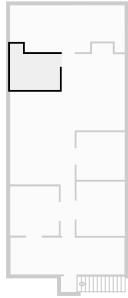

▼ **Bedroom**
1st Floor

WIDTH: 3.10 m • LENGTH: 3.13 m
AREA: 9.70 m² • PERIMETER: 12.46 m

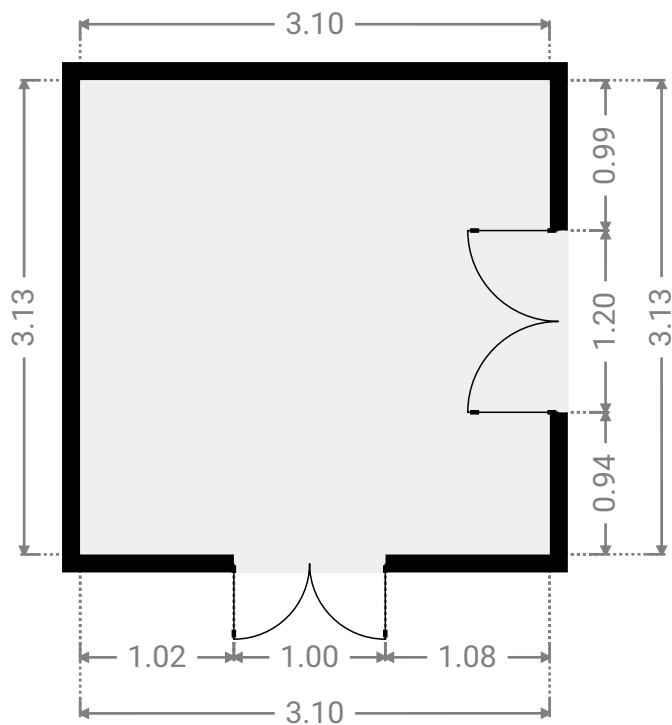
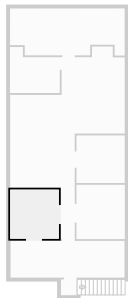

▼ **Bedroom**
1st Floor

WIDTH: 3.08 m • LENGTH: 3.46 m
AREA: 10.66 m² • PERIMETER: 13.08 m

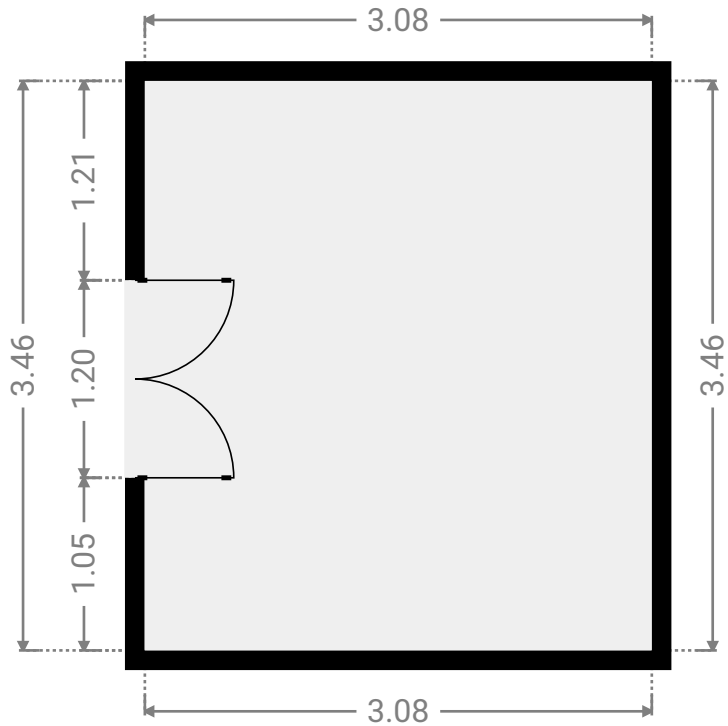
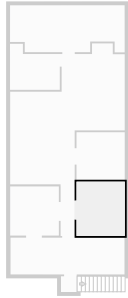

▼ **Bedroom**
1st Floor

WIDTH: 3.07 m • LENGTH: 3.03 m
AREA: 9.30 m² • PERIMETER: 12.20 m

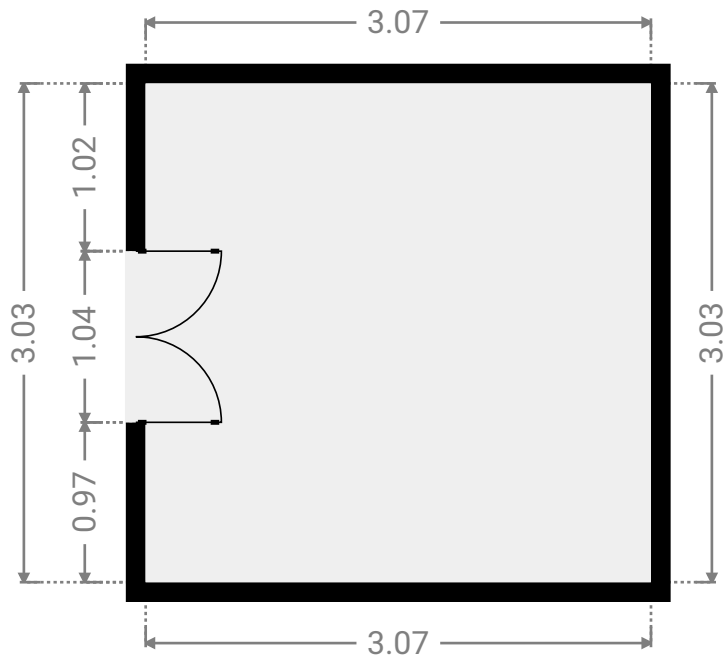
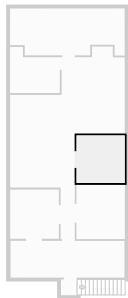

▼ Hall
1st Floor

WIDTH: 0.90 m • LENGTH: 3.19 m
AREA: 2.87 m² • PERIMETER: 8.18 m

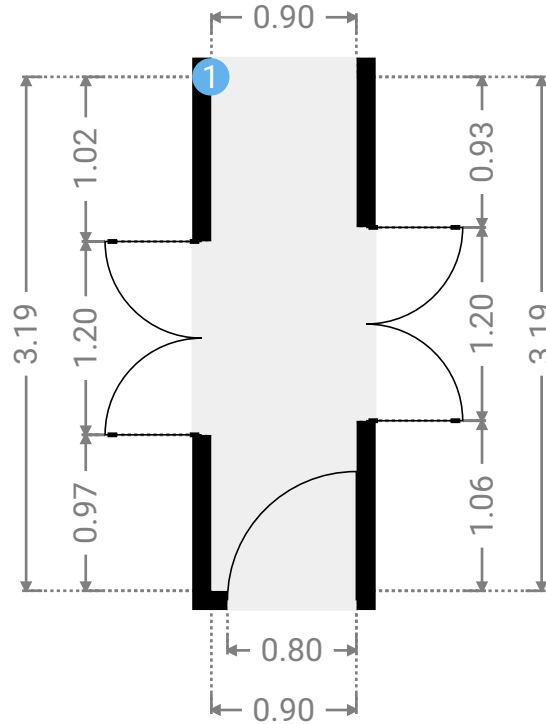
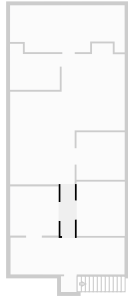

▼ Hall/1st Floor

1 OPENING

Height
0.00 m



▼ Hall
1st Floor

WIDTH: 1.00 m • LENGTH: 1.00 m
AREA: 1.00 m² • PERIMETER: 4.00 m

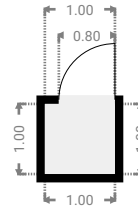
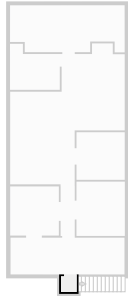

▼ Living Room
1st Floor

WIDTH: 7.30 m • LENGTH: 8.98 m
AREA: 42.62 m² • PERIMETER: 32.55 m

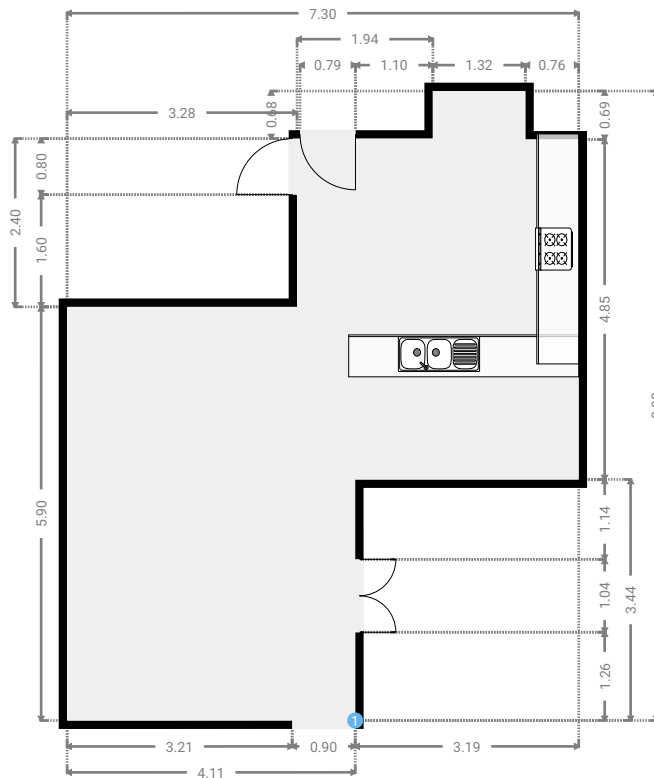
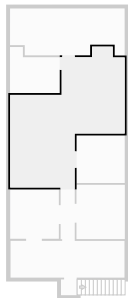

▼ Other
1st Floor

WIDTH: 7.30 m • LENGTH: 3.00 m
AREA: 20.14 m² • PERIMETER: 21.95 m

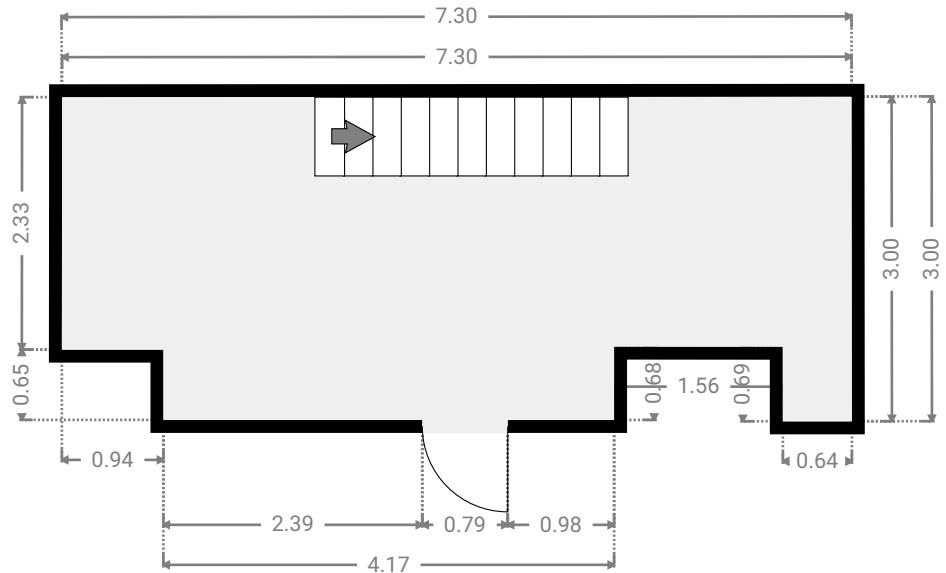
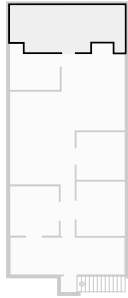

▼ Other
1st Floor

WIDTH: 7.26 m • LENGTH: 2.34 m
AREA: 16.99 m² • PERIMETER: 19.20 m

