

1/90 North Street

SUBMITTED BY

Ray White Rockhampton Casey
stockers@cqoz.com

CREATED ON

2022-11-21

Floors

2

▼ Ground Floor

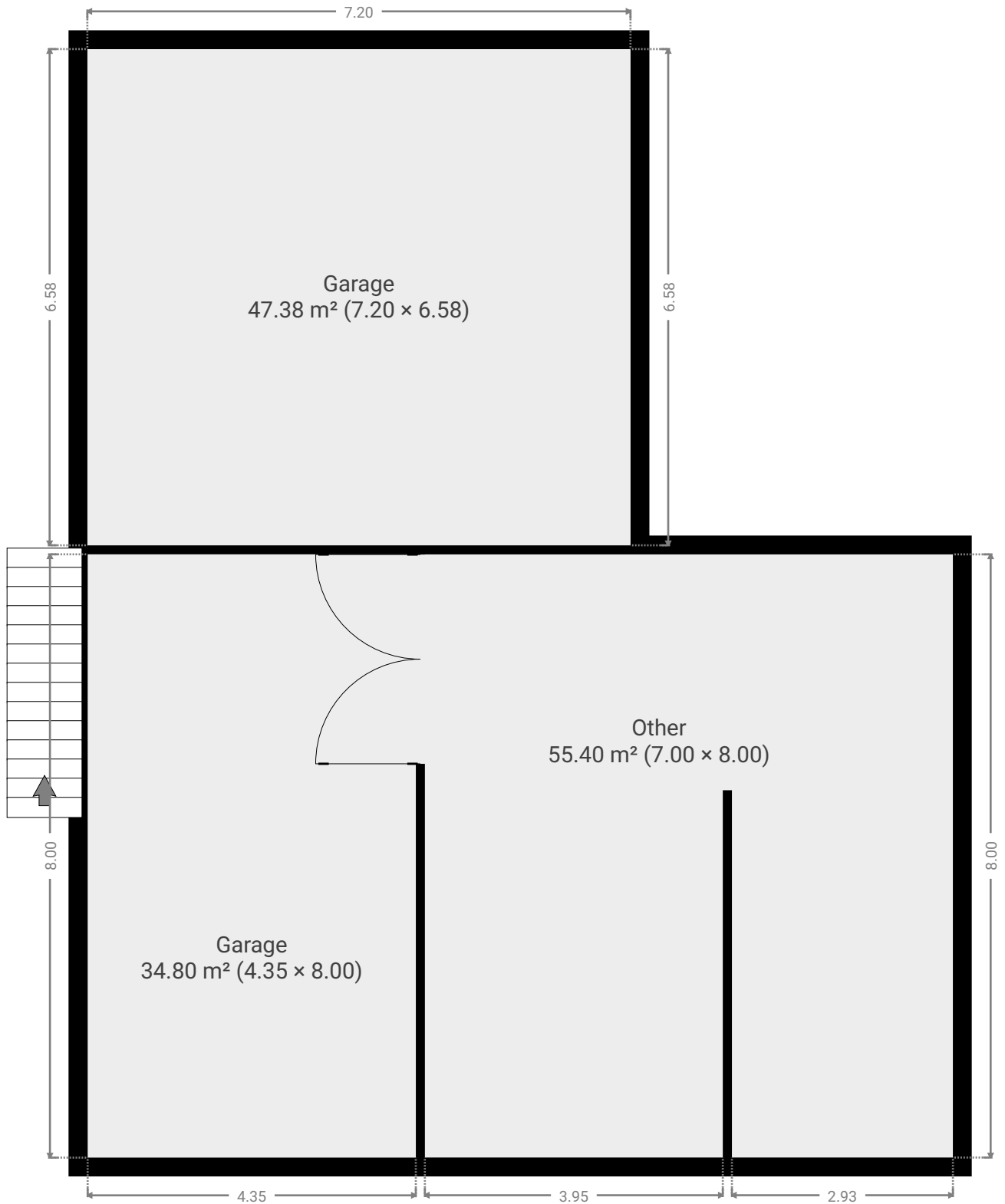

▼ **Garage**
Ground Floor

WIDTH: 8.00 m • LENGTH: 4.35 m
AREA: 34.80 m² • PERIMETER: 24.70 m

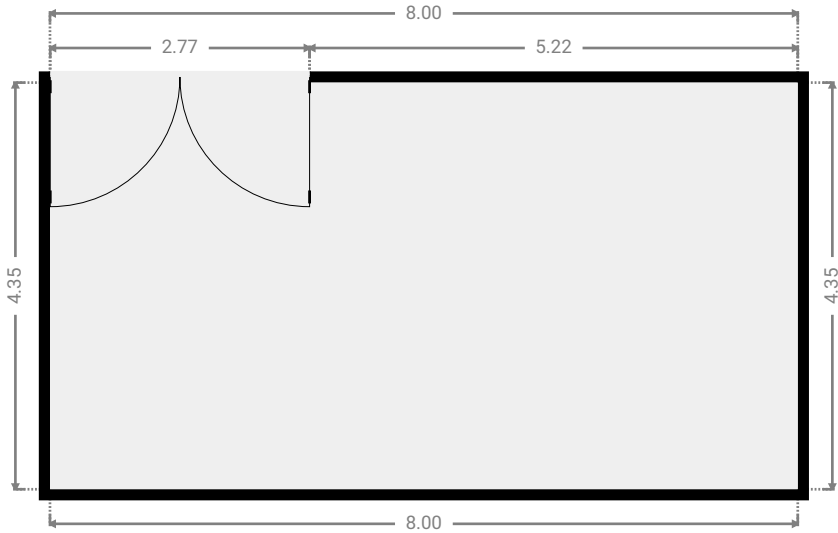
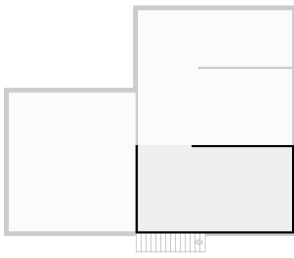

▼ **Garage**
Ground Floor

WIDTH: 6.58 m • LENGTH: 7.20 m
AREA: 47.38 m² • PERIMETER: 27.56 m

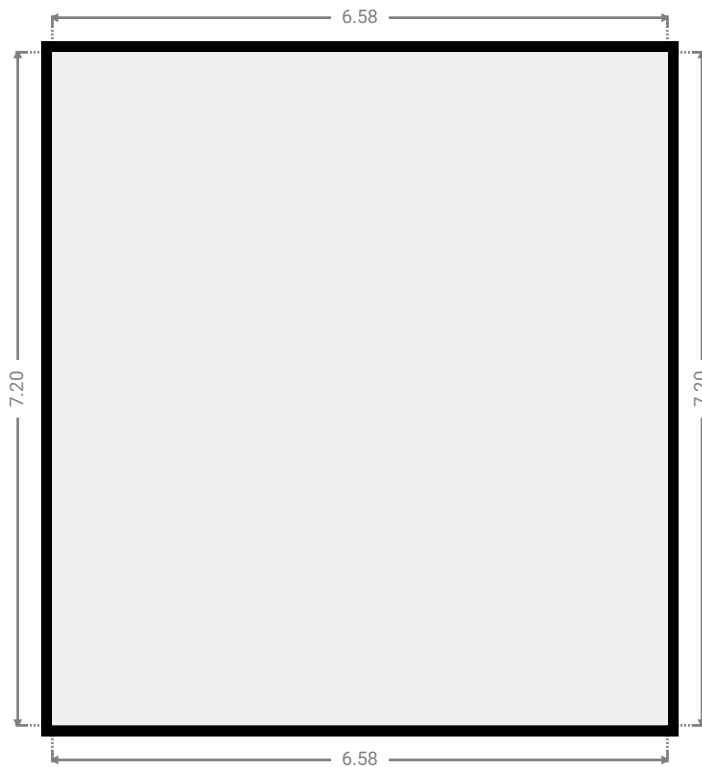
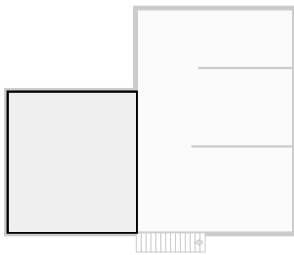

▼ Other
Ground Floor

WIDTH: 8.00 m • LENGTH: 7.00 m
AREA: 55.40 m² • PERIMETER: 39.74 m

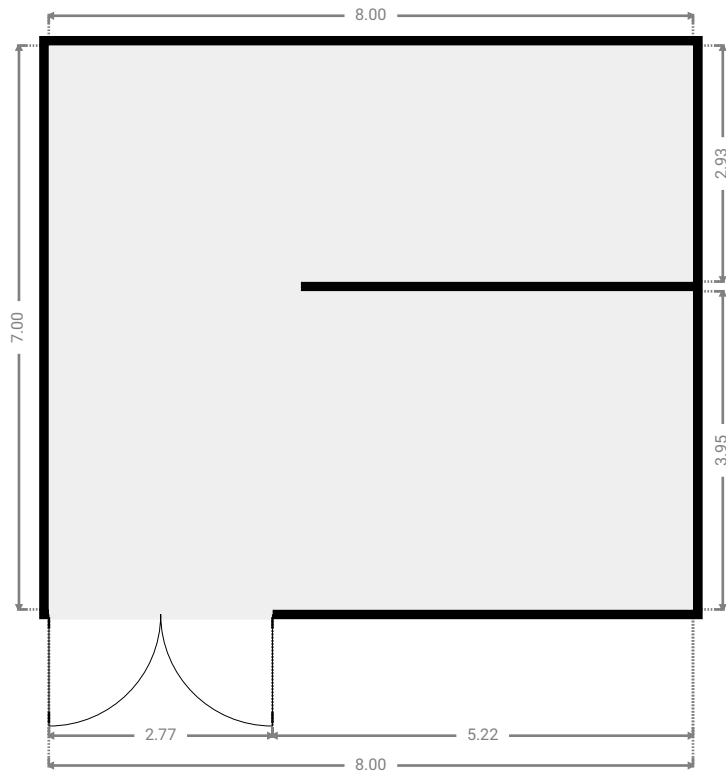
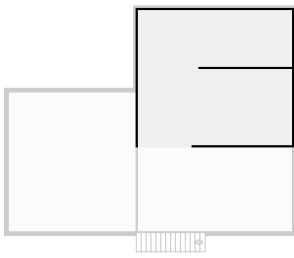

▼ 1st Floor

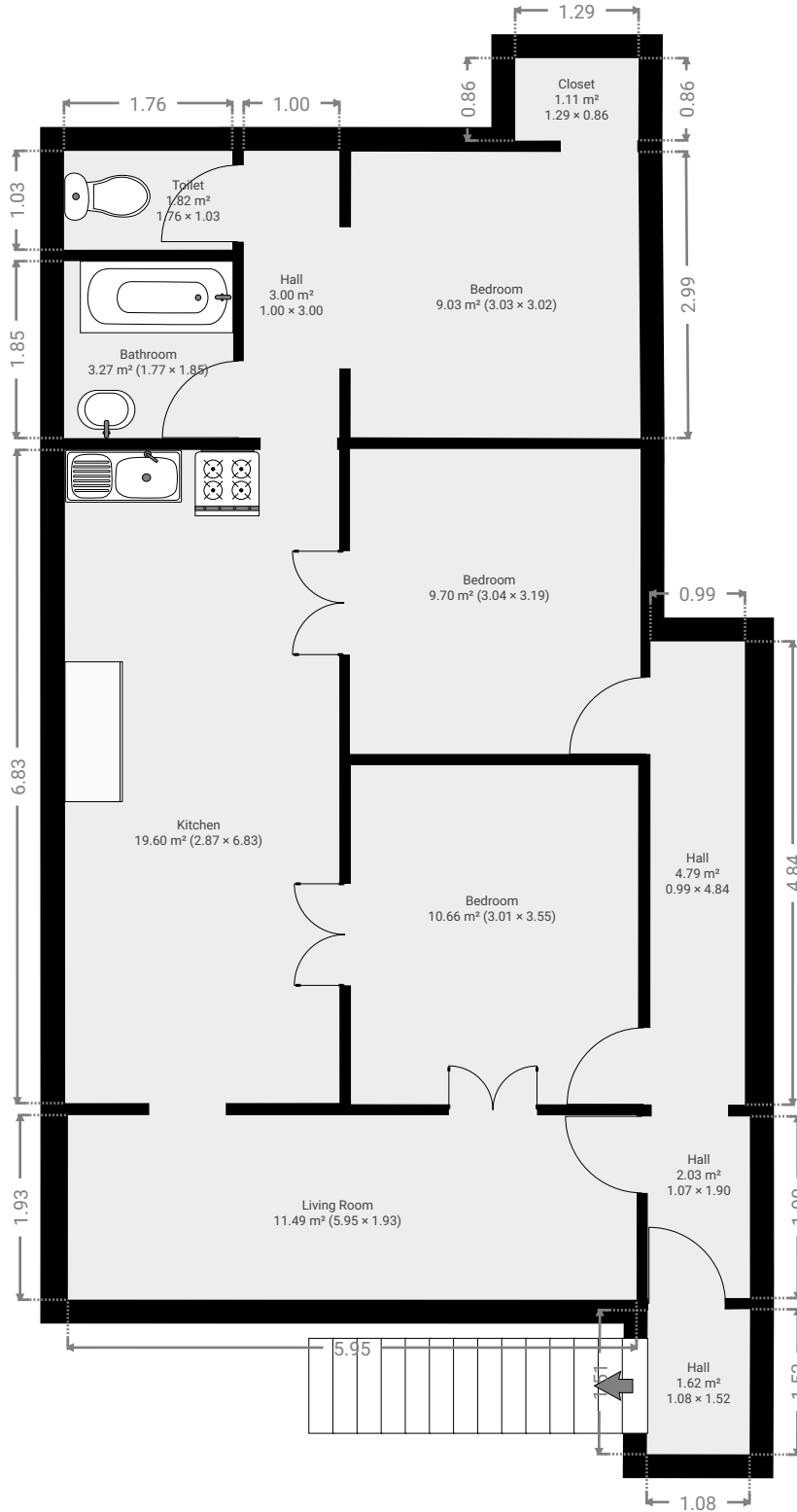

▼ **Bathroom**
1st Floor

WIDTH: 1.77 m • LENGTH: 1.85 m
AREA: 3.27 m² • PERIMETER: 7.24 m

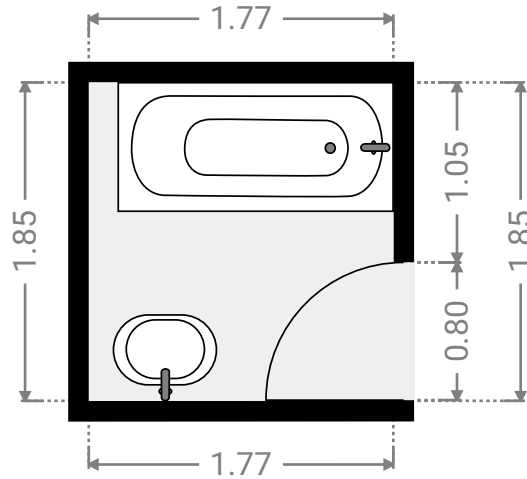
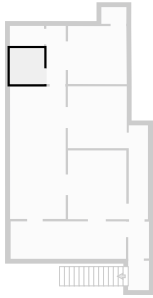

▼ **Bedroom**
1st Floor

WIDTH: 3.04 m • LENGTH: 3.19 m
AREA: 9.70 m² • PERIMETER: 12.46 m

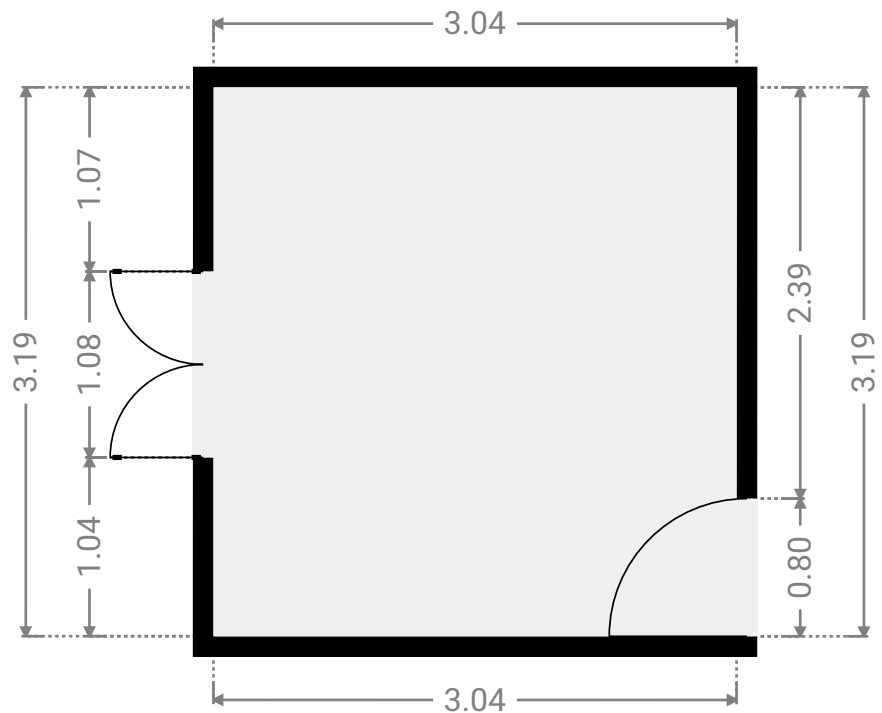
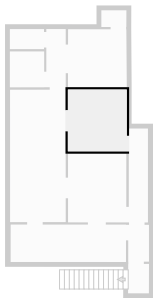

▼ **Bedroom**
1st Floor

WIDTH: 3.03 m • LENGTH: 3.02 m
AREA: 9.03 m² • PERIMETER: 12.02 m

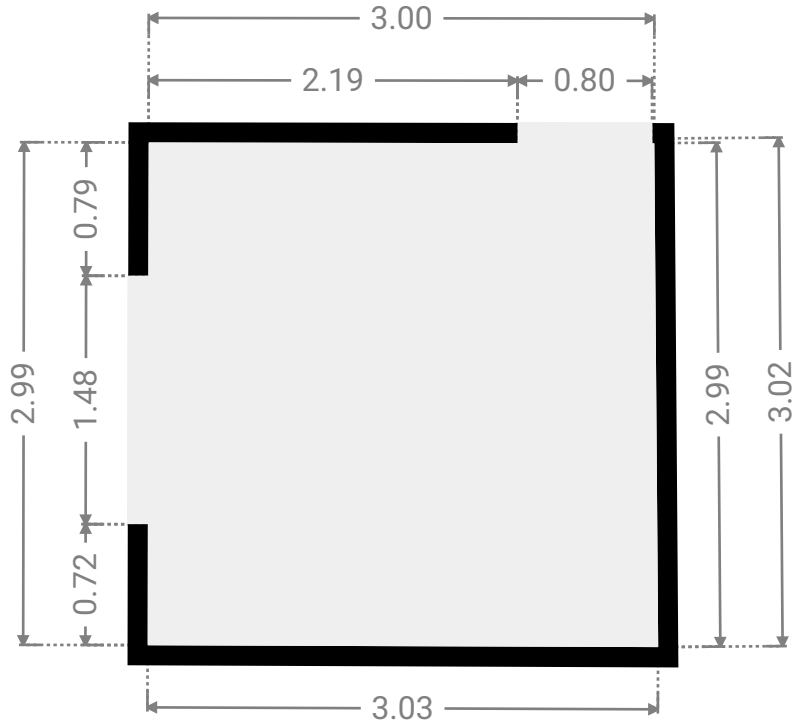
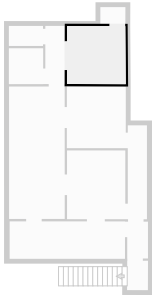

▼ **Closet**
1st Floor

WIDTH: 1.29 m • LENGTH: 0.86 m
AREA: 1.11 m² • PERIMETER: 4.30 m

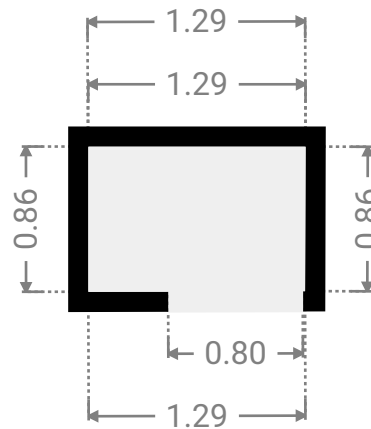
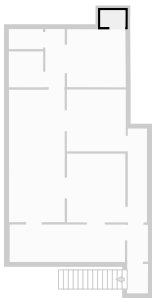

▼ **Bedroom**
1st Floor

WIDTH: 3.01 m • LENGTH: 3.55 m
AREA: 10.66 m² • PERIMETER: 13.10 m

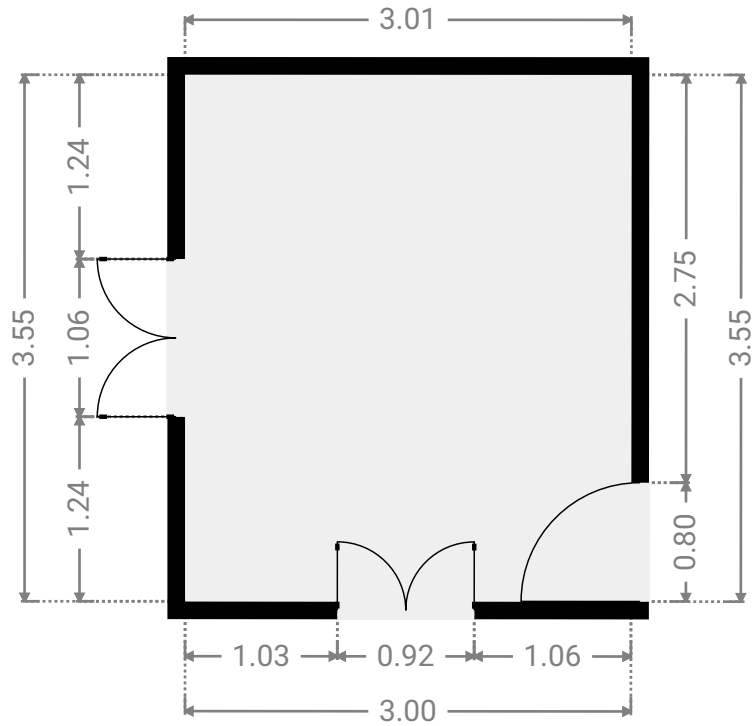
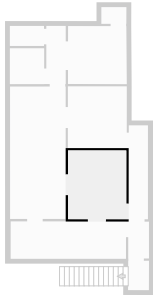

▼ **Hall**
1st Floor

WIDTH: 1.07 m • LENGTH: 1.90 m
AREA: 2.03 m² • PERIMETER: 5.94 m

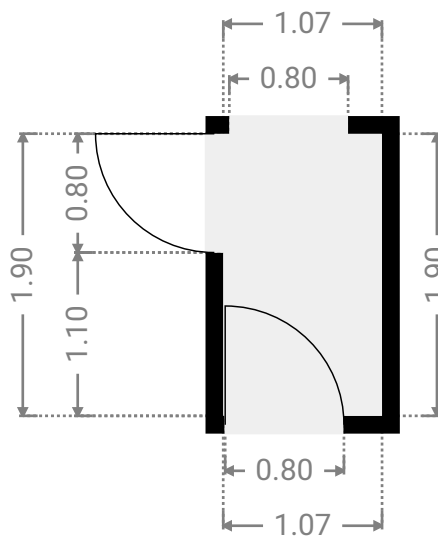
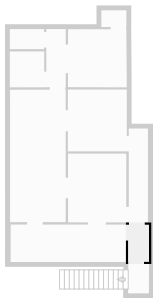

▼ **Hall**
1st Floor

WIDTH: 0.99 m • LENGTH: 4.84 m
AREA: 4.79 m² • PERIMETER: 11.67 m

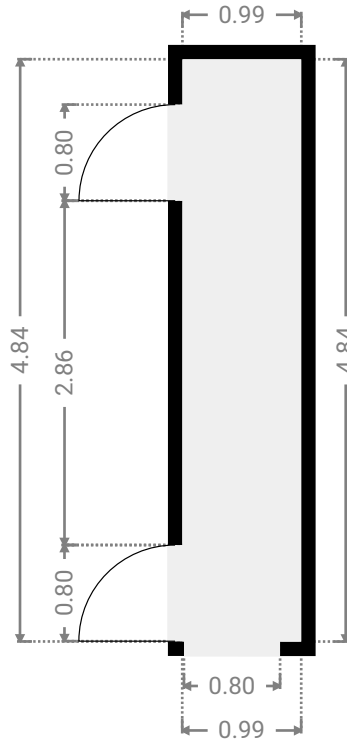
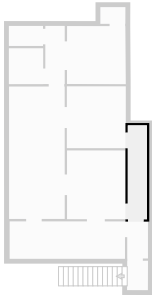

▼ **Hall**
1st Floor

WIDTH: 1.00 m • LENGTH: 3.00 m
AREA: 3.00 m² • PERIMETER: 8.00 m

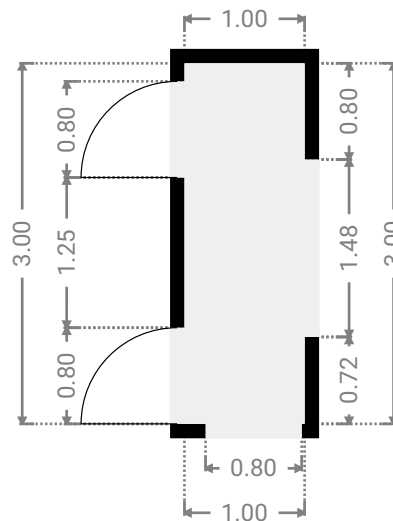
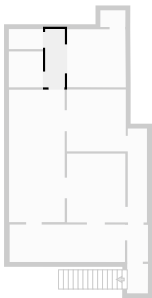

▼ **Hall**
1st Floor

WIDTH: 1.08 m • LENGTH: 1.52 m
AREA: 1.62 m² • PERIMETER: 5.17 m

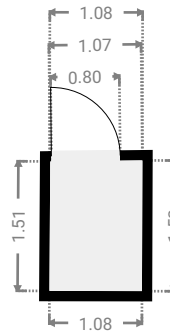
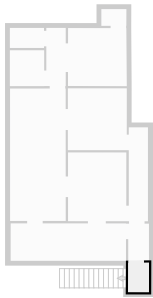

▼ **Kitchen**
1st Floor

WIDTH: 2.87 m • LENGTH: 6.83 m
AREA: 19.60 m² • PERIMETER: 19.40 m

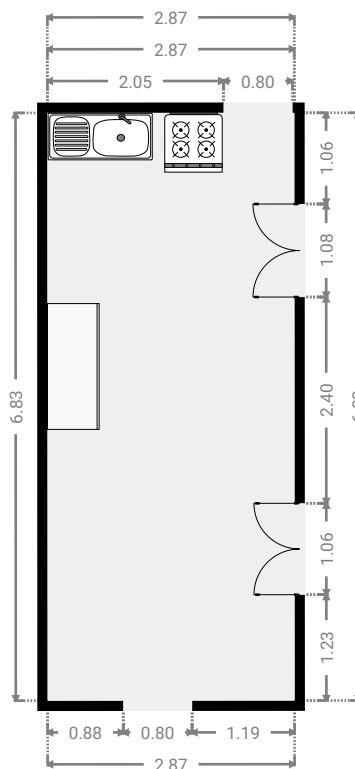
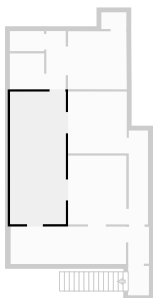

▼ **Living Room**
1st Floor

WIDTH: 5.95 m • LENGTH: 1.93 m
AREA: 11.49 m² • PERIMETER: 15.76 m

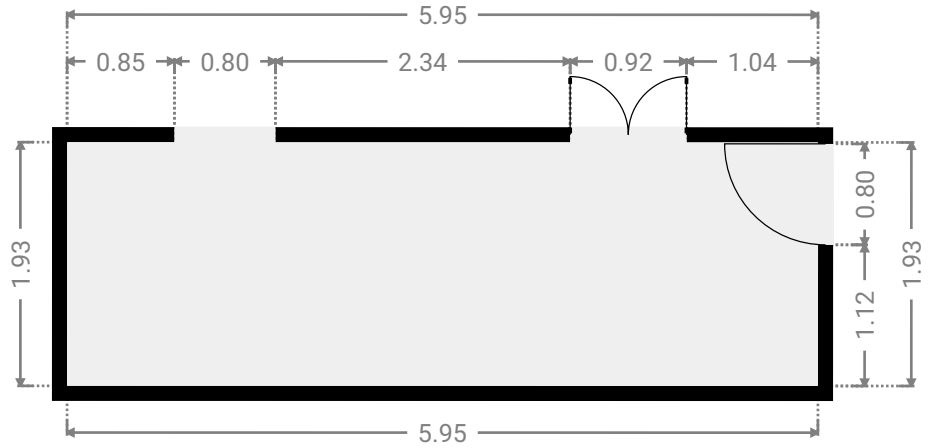
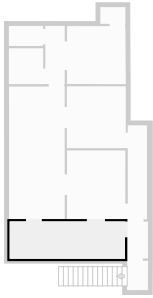

▼ **Toilet**
1st Floor

WIDTH: 1.76 m • LENGTH: 1.03 m
AREA: 1.82 m² • PERIMETER: 5.59 m

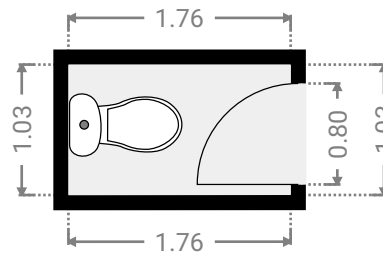
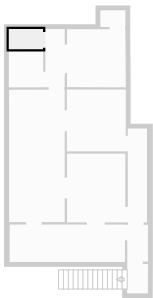

2/90 North Street

SUBMITTED BY
Ray White Rockhampton Casey
stockers@cqoz.com

CREATED ON
2022-11-21

Floors 2

▼ Ground Floor

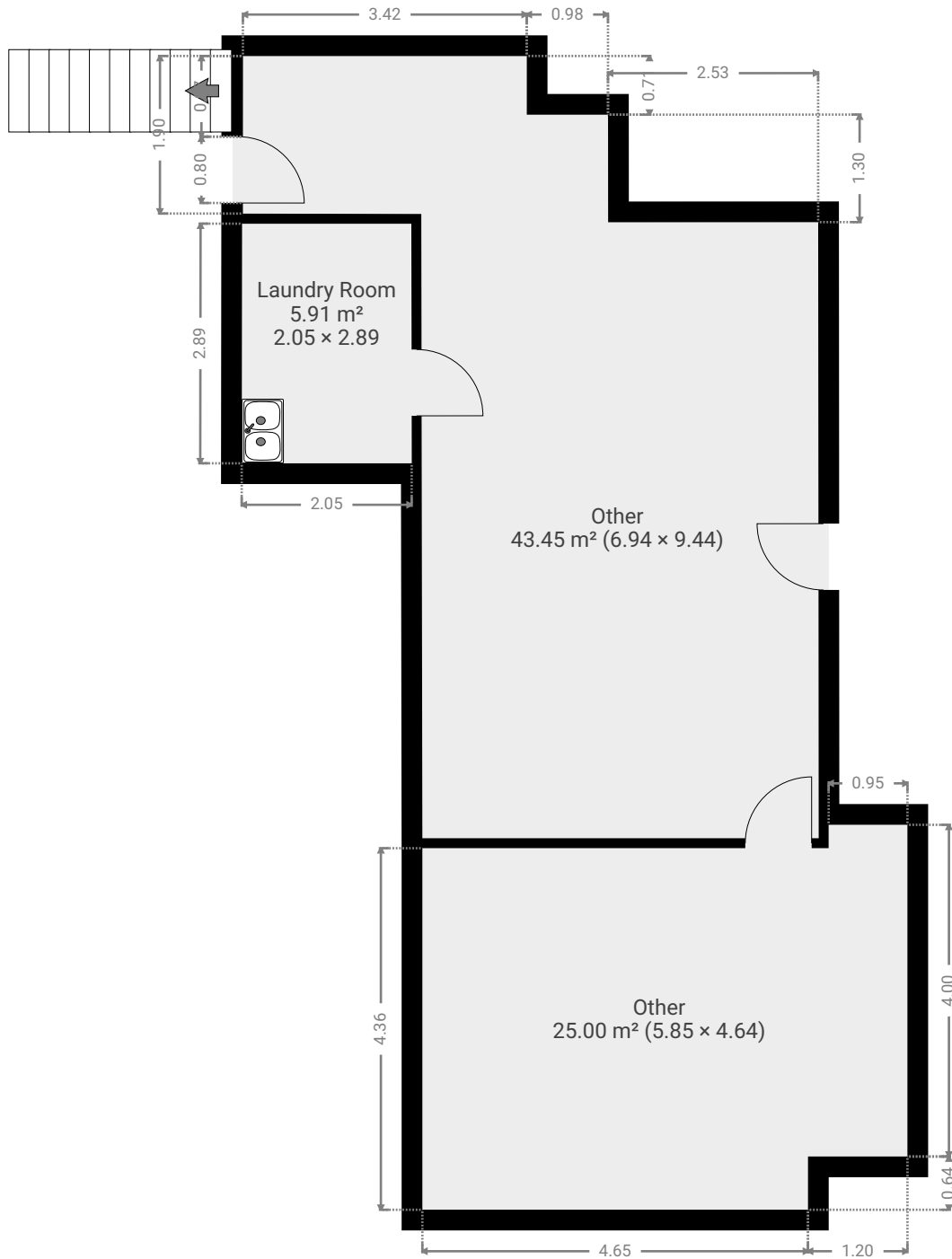

▼ Laundry Room
Ground Floor

WIDTH: 2.05 m • LENGTH: 2.89 m
AREA: 5.91 m² • PERIMETER: 9.87 m

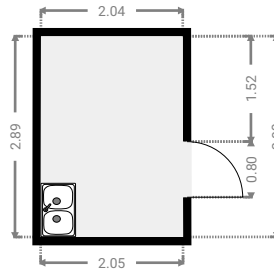
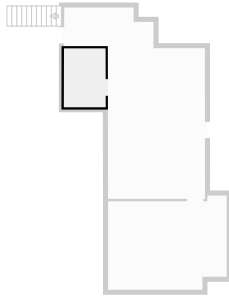

▼ Other
Ground Floor

WIDTH: 6.94 m • LENGTH: 9.44 m
AREA: 43.45 m² • PERIMETER: 32.73 m

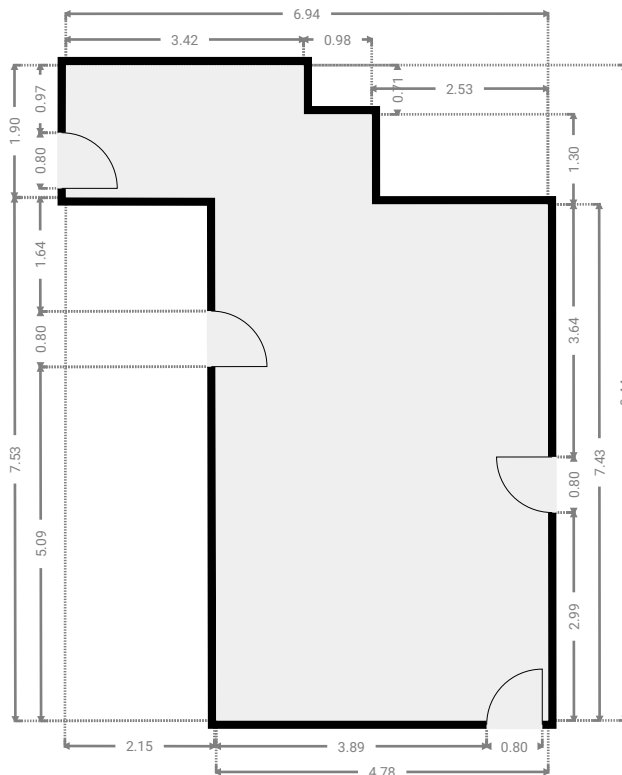
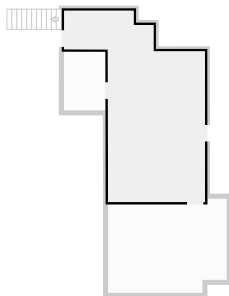

▼ Other
Ground Floor

WIDTH: 5.85 m • LENGTH: 4.64 m
AREA: 25.00 m² • PERIMETER: 20.98 m

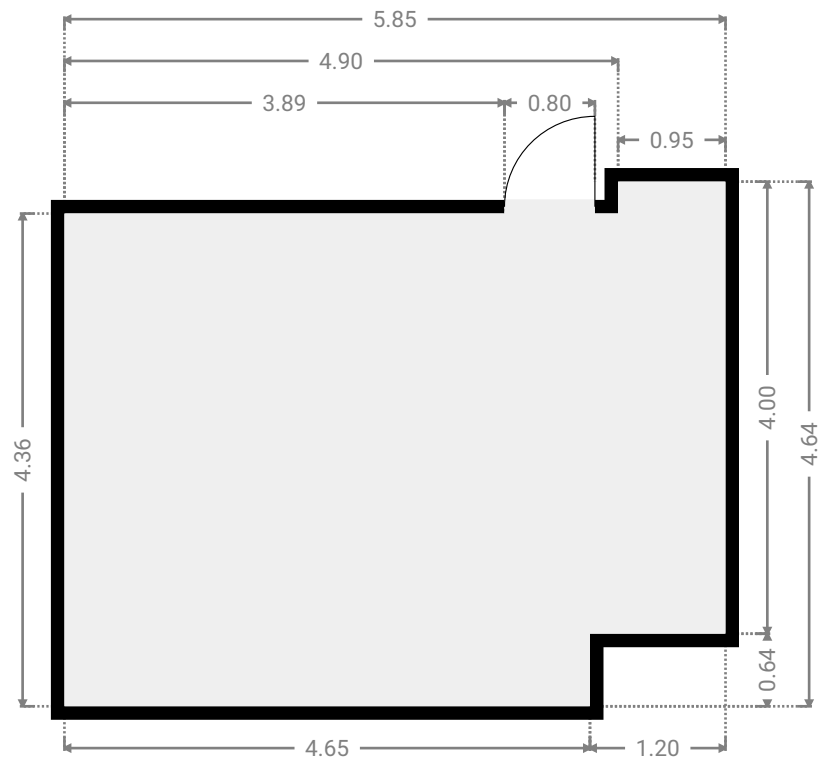
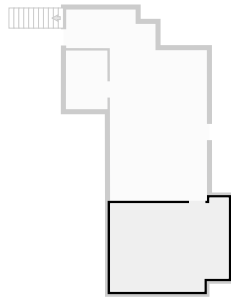

▼ 1st Floor



▼ Bathroom
1st Floor

WIDTH: 2.90 m • LENGTH: 2.19 m
AREA: 6.36 m² • PERIMETER: 10.18 m

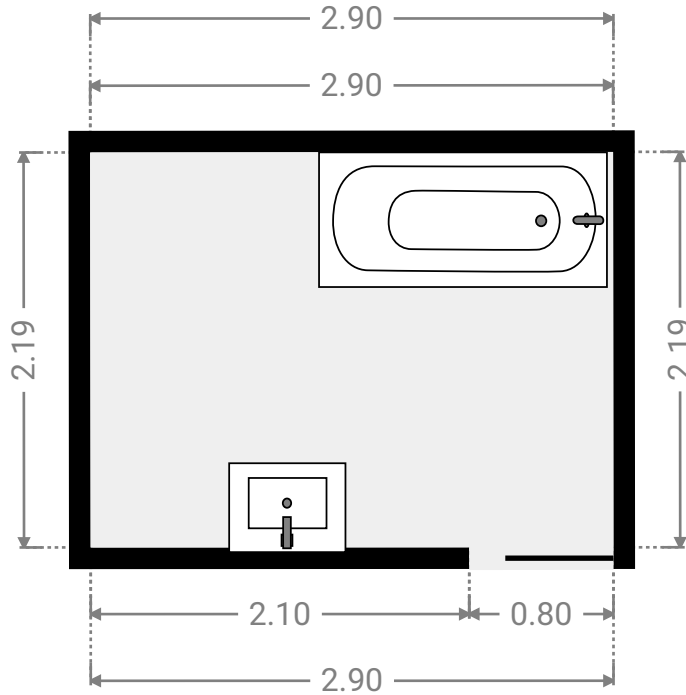
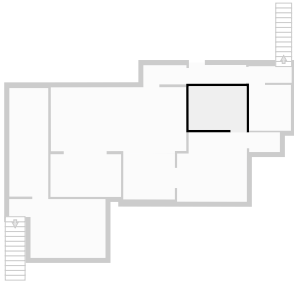

▼ Bathroom
1st Floor

WIDTH: 2.10 m • LENGTH: 2.30 m
AREA: 4.83 m² • PERIMETER: 8.80 m

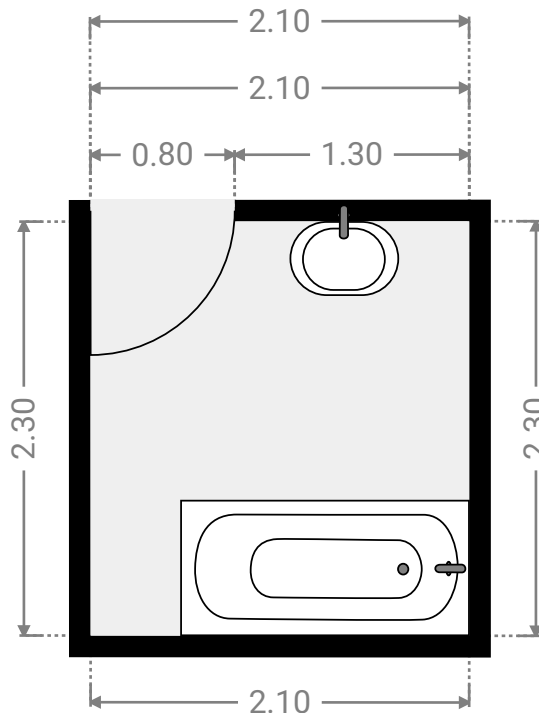
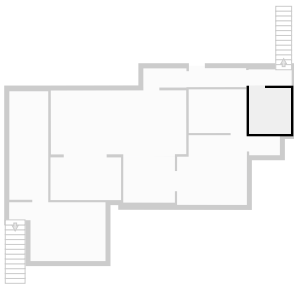

▼ **Bedroom**
1st Floor

WIDTH: 3.50 m • LENGTH: 3.50 m
AREA: 11.61 m² • PERIMETER: 13.99 m

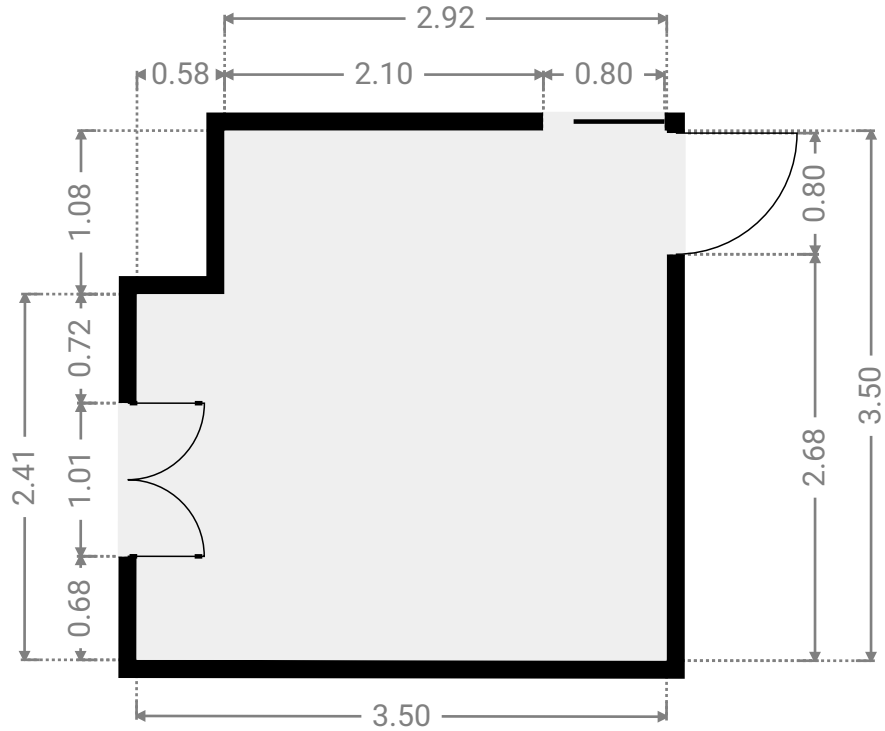
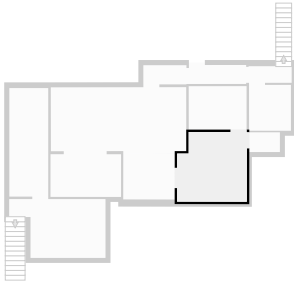

▼ **Dining Room**
1st Floor

WIDTH: 2.59 m • LENGTH: 2.30 m
AREA: 5.95 m² • PERIMETER: 9.78 m

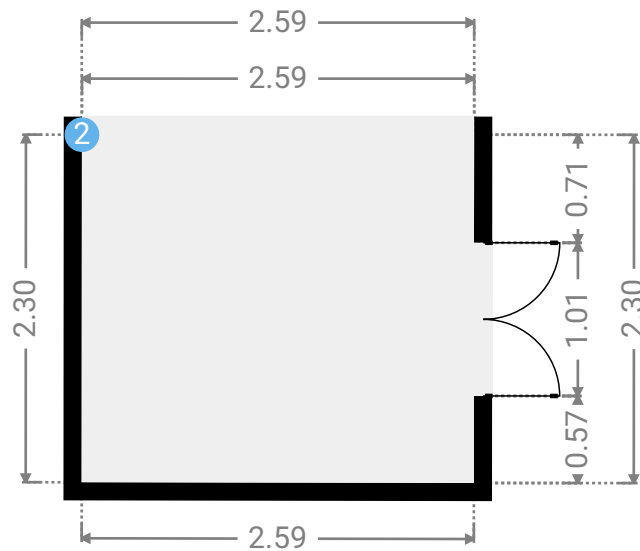
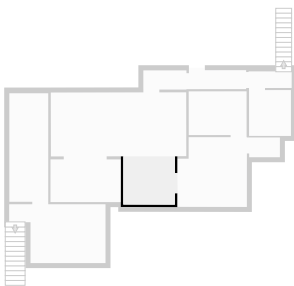

▼ Dining Room/1st Floor

2 OPENING

Height
0.00 m



▼ **Hall**
1st Floor

WIDTH: 2.16 m • LENGTH: 0.96 m
AREA: 2.07 m² • PERIMETER: 6.24 m

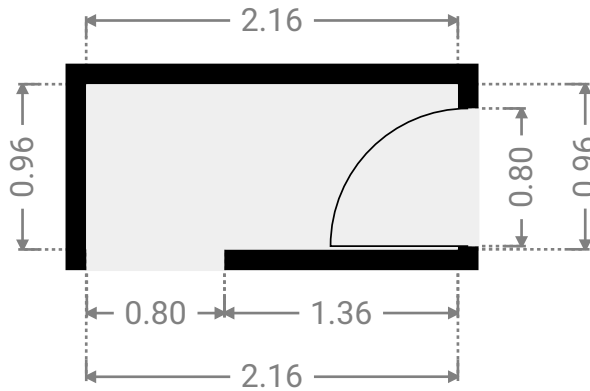
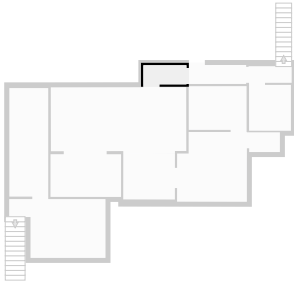

▼ **Hall**
1st Floor

WIDTH: 2.87 m • LENGTH: 0.95 m
AREA: 2.73 m² • PERIMETER: 7.64 m

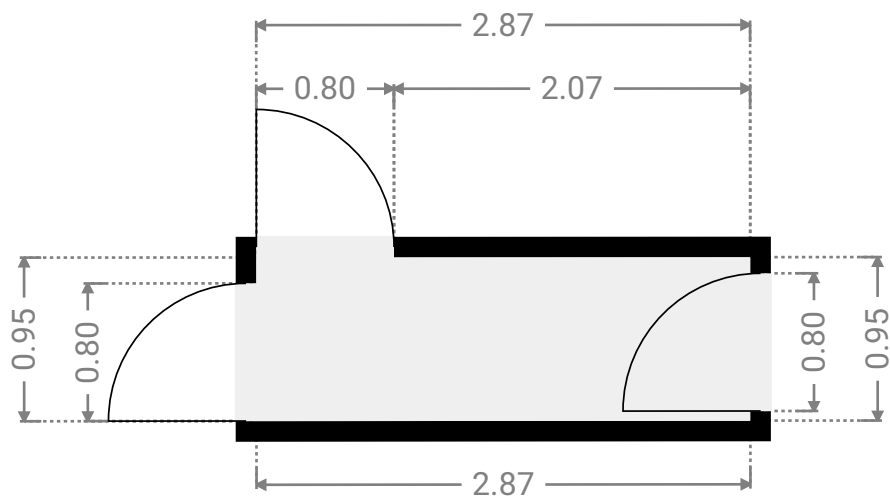
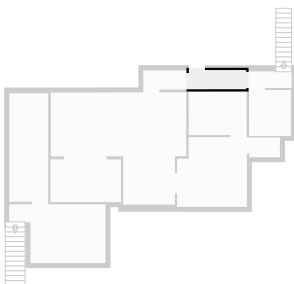

▼ **Hall**
1st Floor

WIDTH: 2.16 m • LENGTH: 0.83 m
AREA: 1.80 m² • PERIMETER: 5.98 m

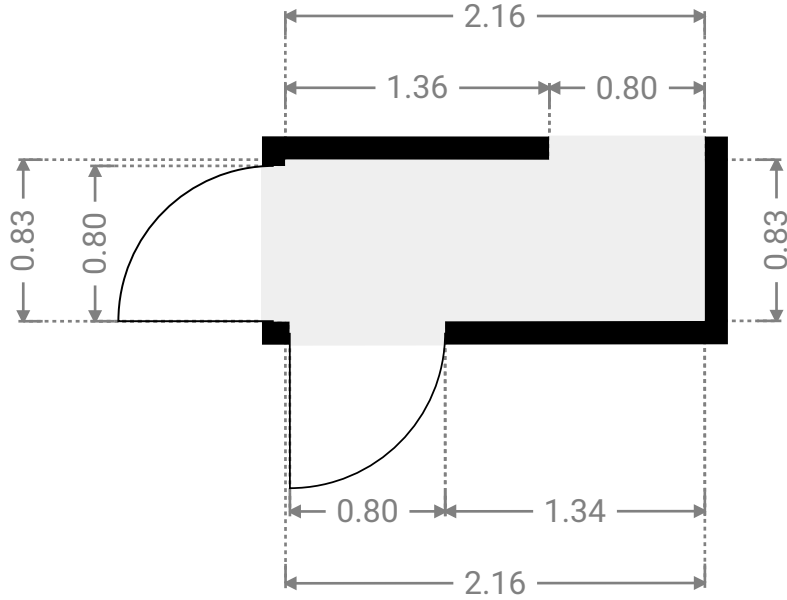
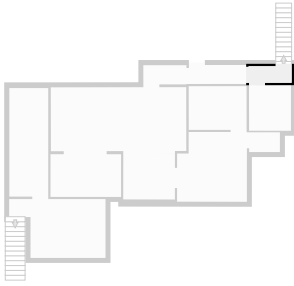

▼ **Kitchen**
1st Floor

WIDTH: 3.54 m • LENGTH: 2.14 m
AREA: 7.58 m² • PERIMETER: 11.36 m

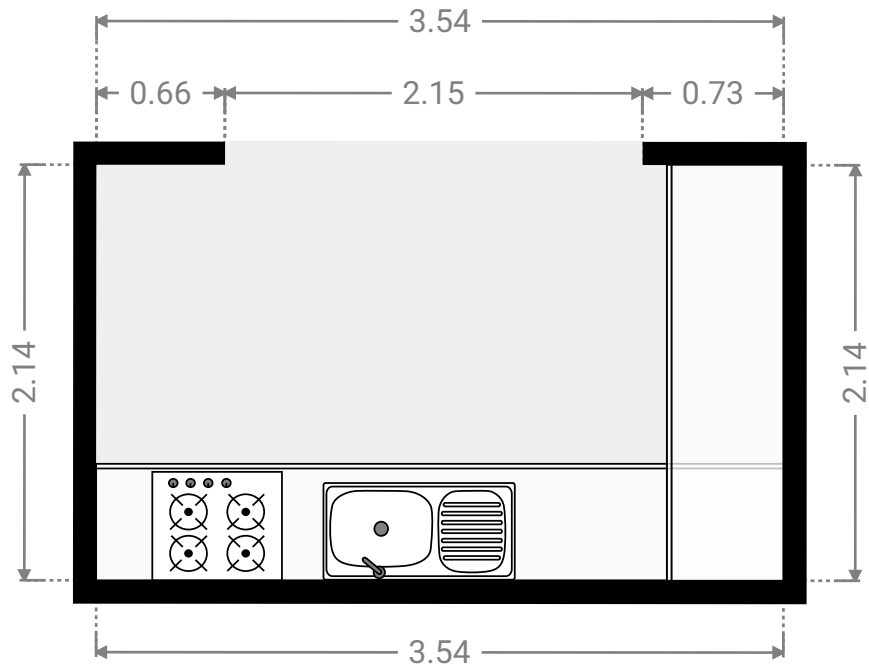
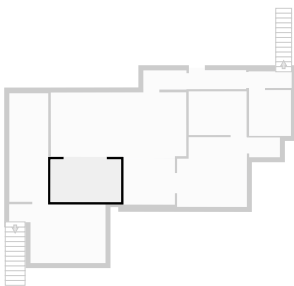

▼ **Living Room**
1st Floor

WIDTH: 4.83 m • LENGTH: 2.95 m
AREA: 12.06 m² • PERIMETER: 15.56 m

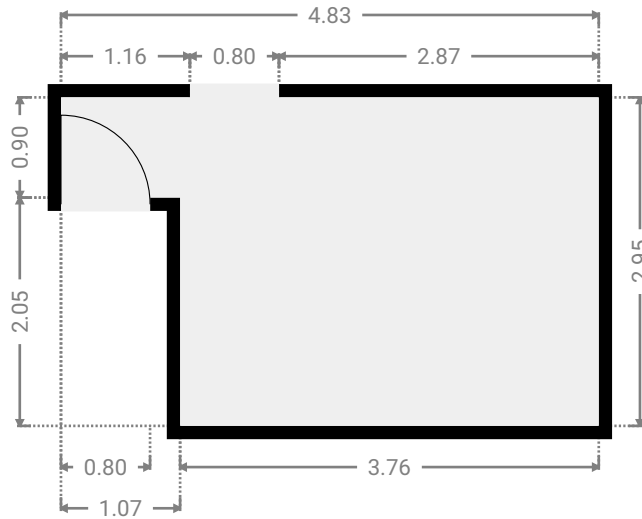
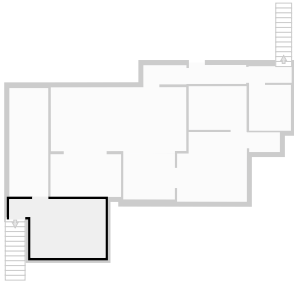

▼ **Living Room**
1st Floor

WIDTH: 1.95 m • LENGTH: 5.44 m
AREA: 10.61 m² • PERIMETER: 14.78 m

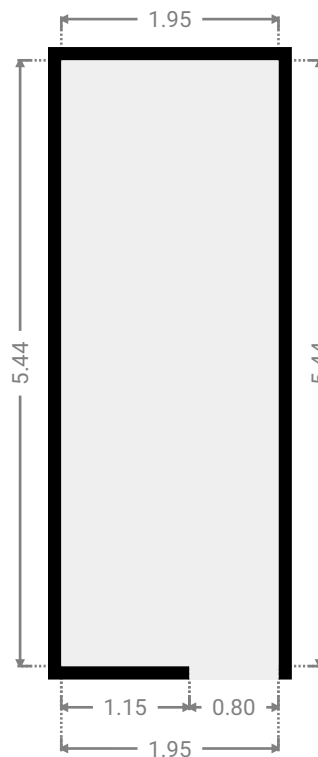
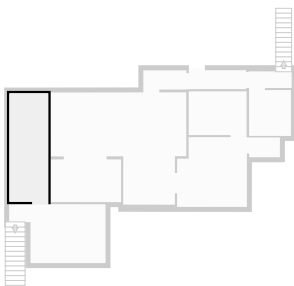

▼ **Living Room**
1st Floor

WIDTH: 6.79 m • LENGTH: 3.20 m
AREA: 21.74 m² • PERIMETER: 19.98 m

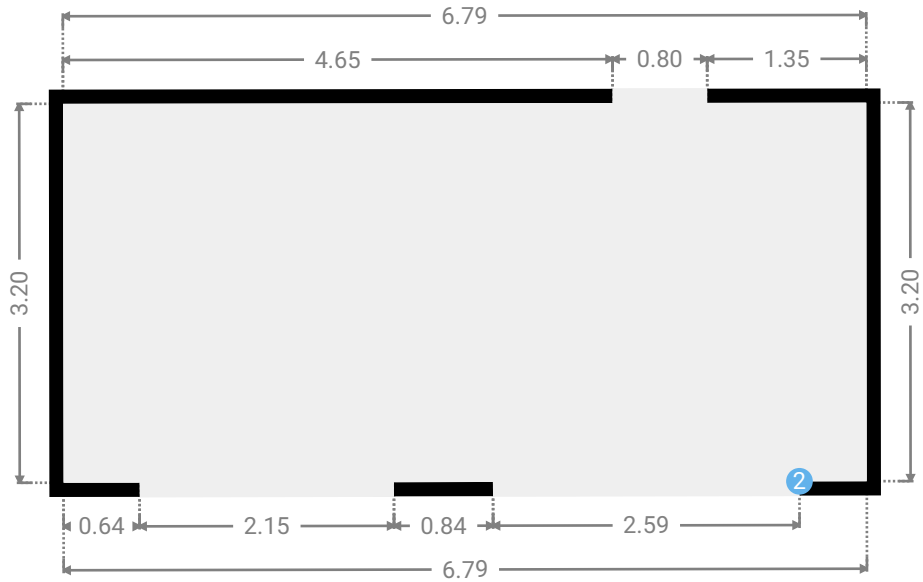
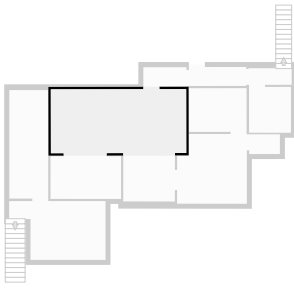

▼ **Toilet**
1st Floor

WIDTH: 1.54 m • LENGTH: 0.99 m
AREA: 1.52 m² • PERIMETER: 5.06 m

