

9 Peatey Street

SUBMITTED BY
Ray White Rockhampton Casey
stockers@cqoz.com

CREATED ON
2022-04-04

Floors
2

▼ Ground Floor

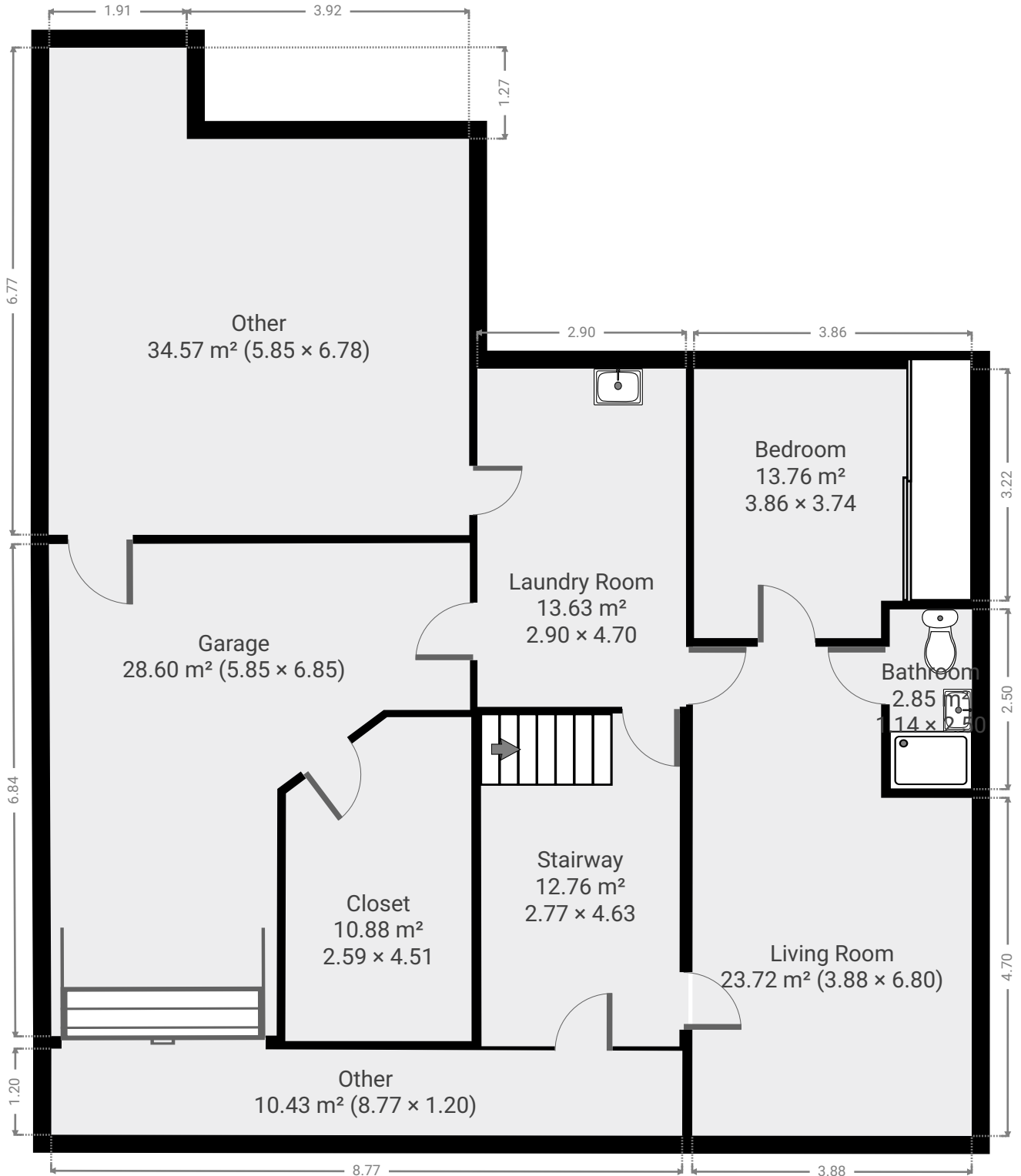

▼ **Stairway**
Ground Floor

WIDTH: 2.77 m • LENGTH: 4.63 m
AREA: 12.76 m² • PERIMETER: 14.77 m

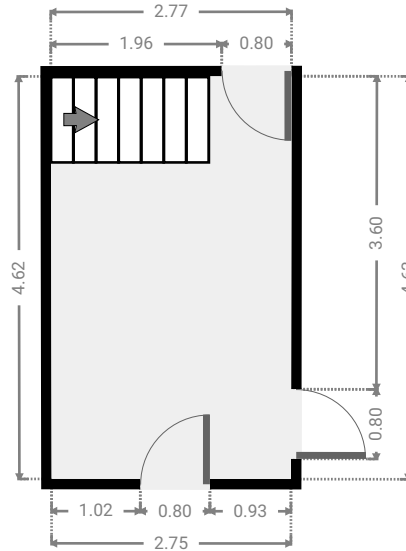
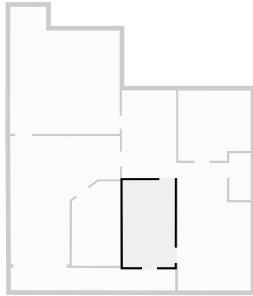

▼ **Living Room**
Ground Floor

WIDTH: 3.89 m • LENGTH: 6.80 m
AREA: 23.72 m² • PERIMETER: 21.35 m

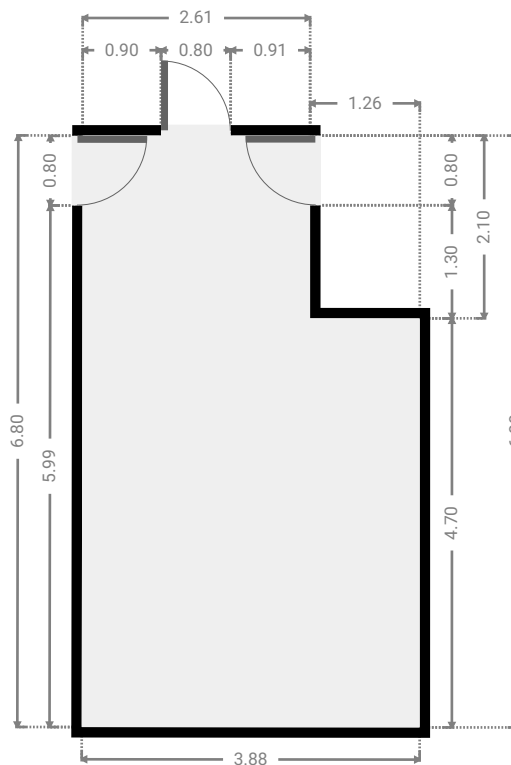
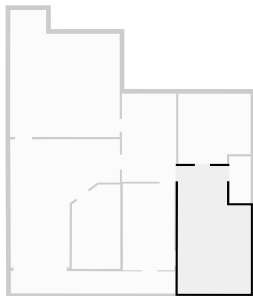

▼ **Bathroom**
Ground Floor

WIDTH: 1.13 m • LENGTH: 2.50 m
AREA: 2.85 m² • PERIMETER: 7.28 m

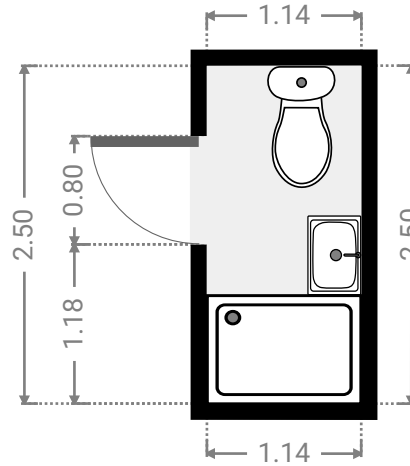
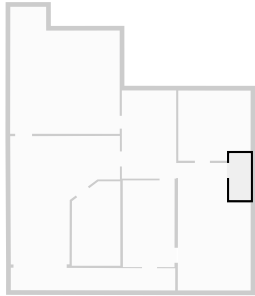

▼ **Bedroom**
Ground Floor

WIDTH: 3.81 m • LENGTH: 3.74 m
AREA: 13.76 m² • PERIMETER: 15.19 m

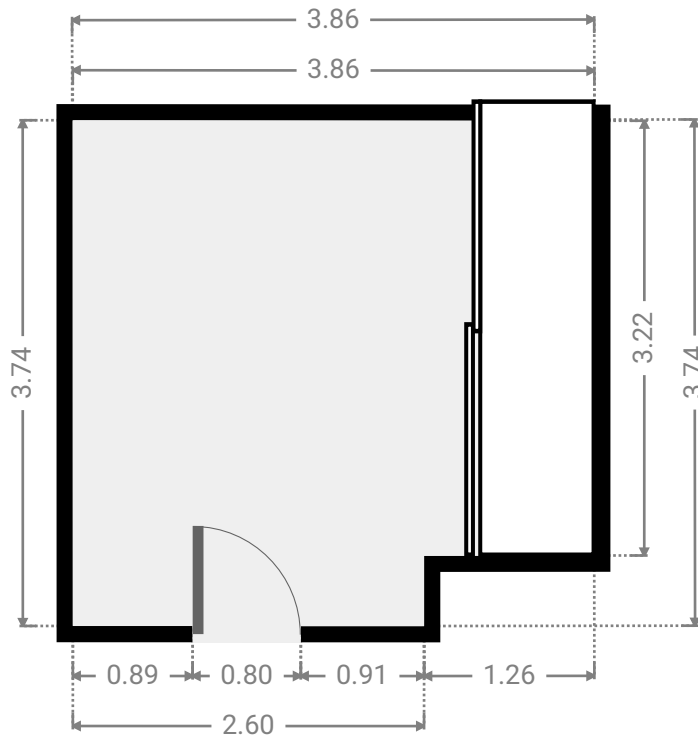
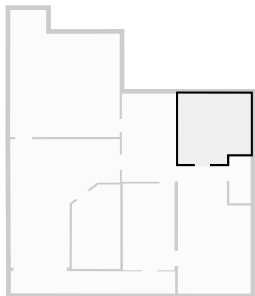

▼ **Laundry Room**
Ground Floor

WIDTH: 2.90 m • LENGTH: 4.70 m
AREA: 13.63 m² • PERIMETER: 15.20 m

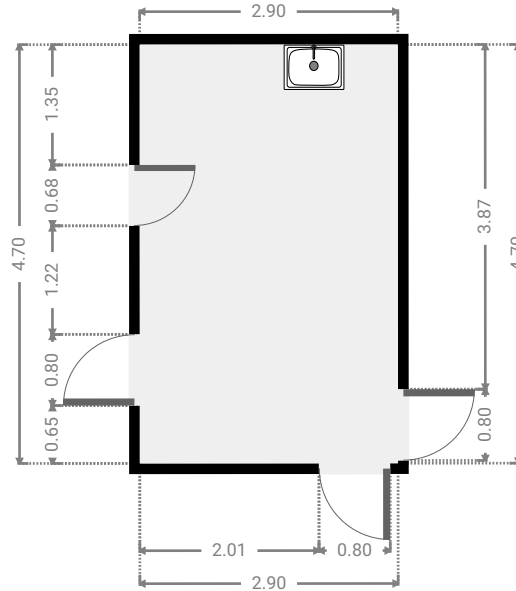
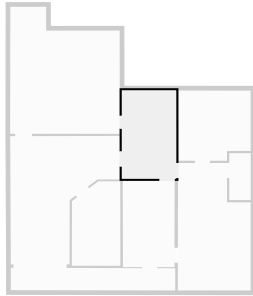

▼ **Garage**
Ground Floor

WIDTH: 5.85 m • LENGTH: 6.85 m
AREA: 28.60 m² • PERIMETER: 24.61 m

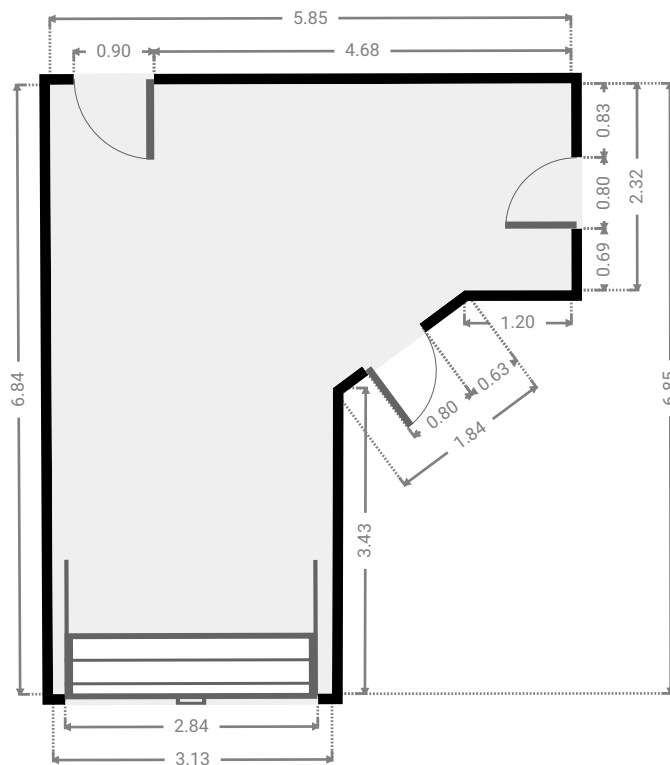
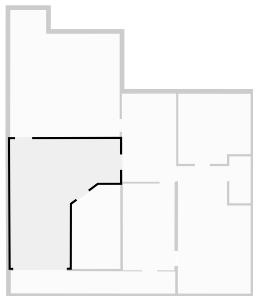

▼ **Closet**
Ground Floor

WIDTH: 2.60 m • LENGTH: 4.39 m
AREA: 10.88 m² • PERIMETER: 13.47 m

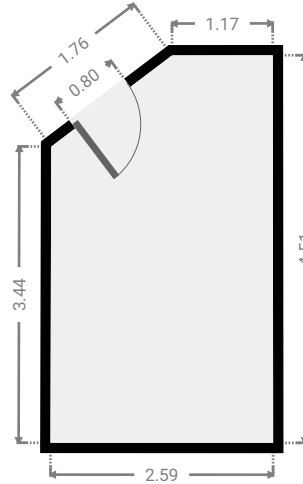
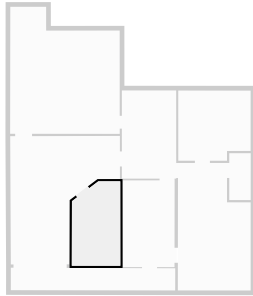

▼ **Other**
Ground Floor

WIDTH: 5.85 m • LENGTH: 6.78 m
AREA: 34.57 m² • PERIMETER: 25.22 m

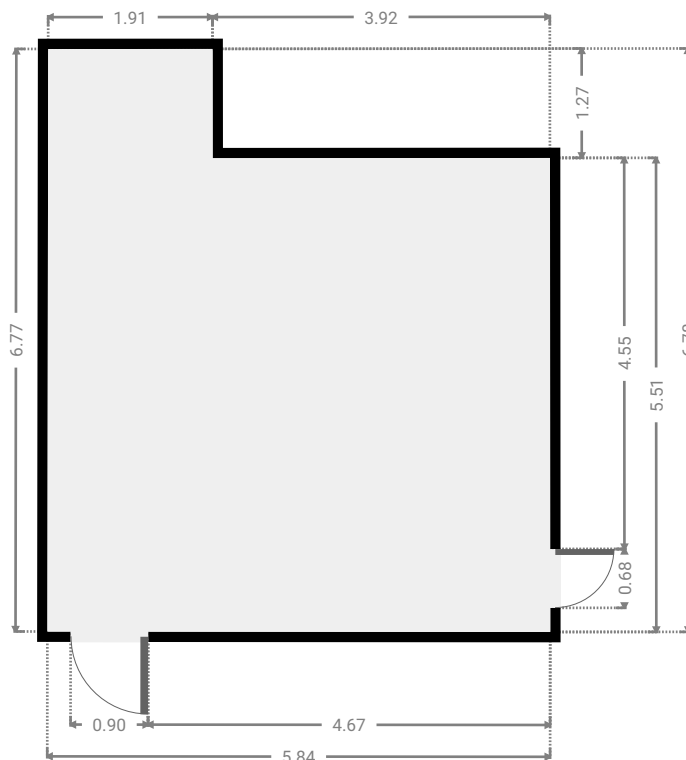
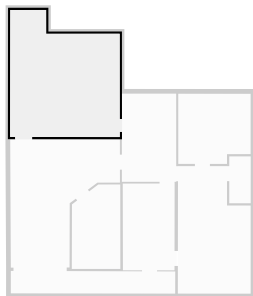

▼ Other Ground Floor

WIDTH: 8.84 m • LENGTH: 1.26 m
AREA: 10.43 m² • PERIMETER: 19.91 m

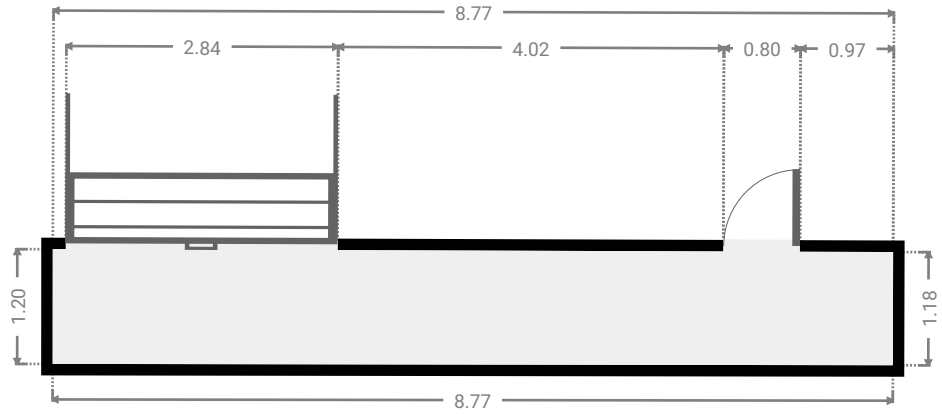
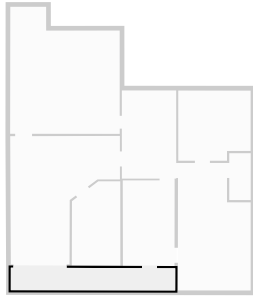

▼ 1st Floor

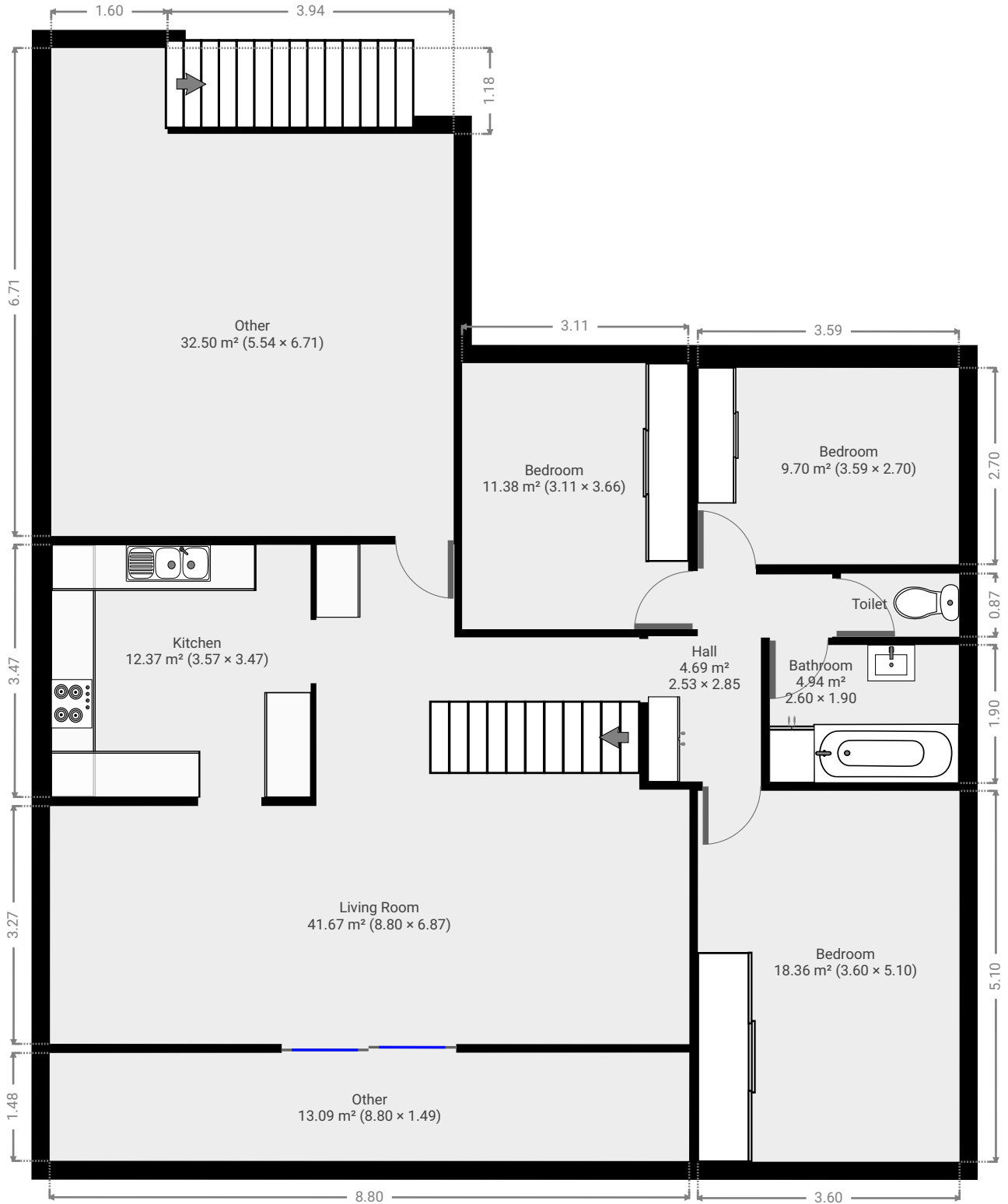

▼ Living Room
1st Floor

WIDTH: 8.80 m • LENGTH: 6.87 m
AREA: 41.67 m² • PERIMETER: 31.33 m

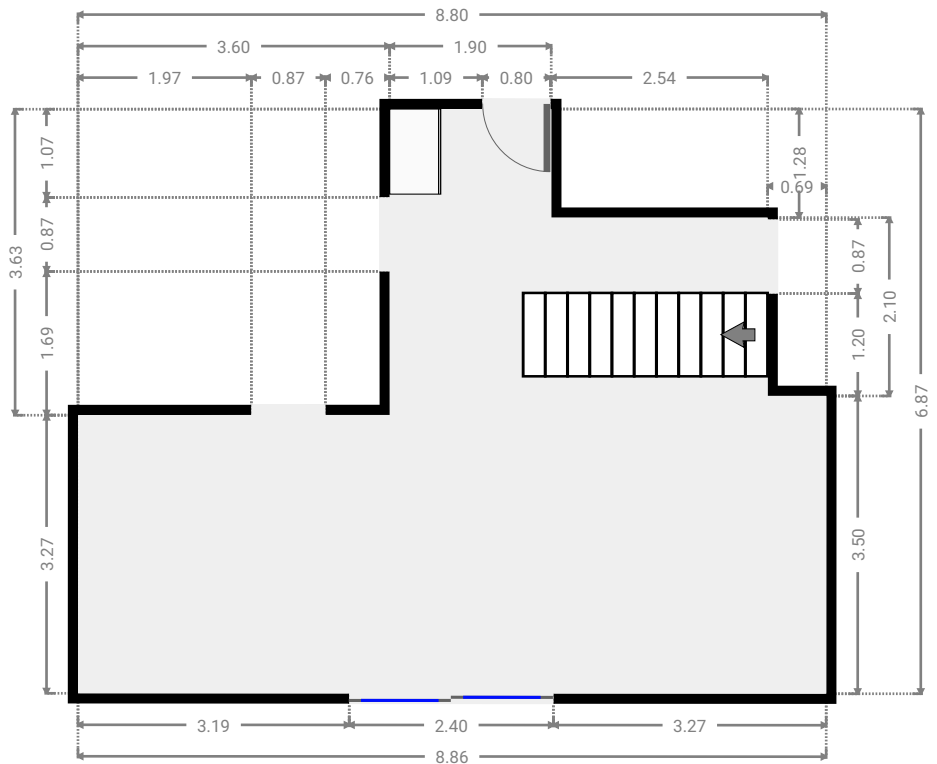
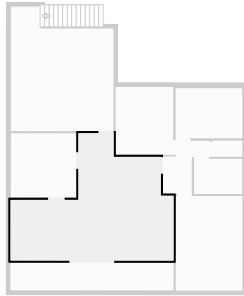

▼ Kitchen
1st Floor

WIDTH: 3.57 m • LENGTH: 3.47 m
AREA: 12.37 m² • PERIMETER: 14.07 m

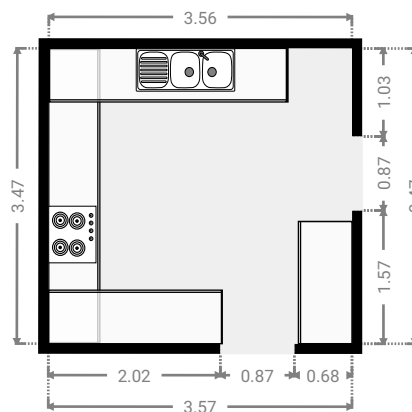
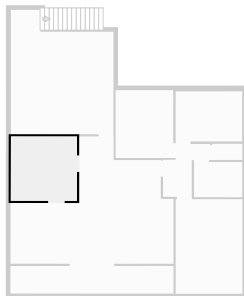

▼ **Hall**
1st Floor

WIDTH: 2.53 m • LENGTH: 2.85 m
AREA: 4.69 m² • PERIMETER: 10.76 m

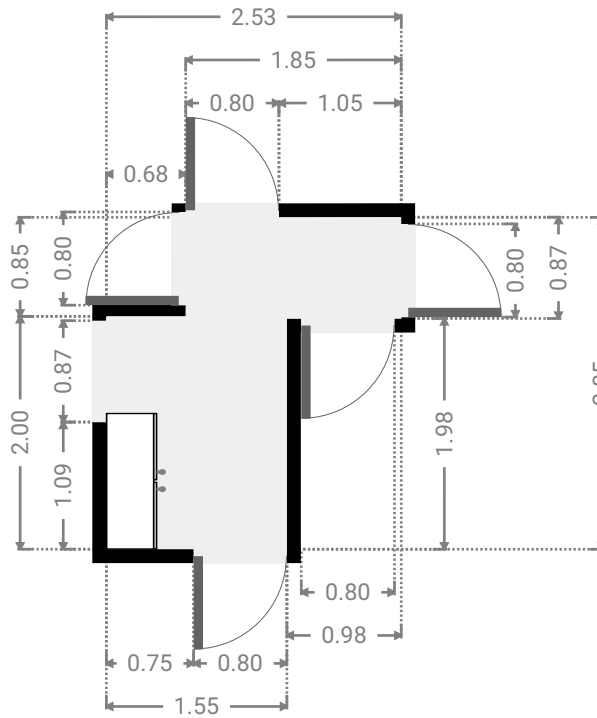
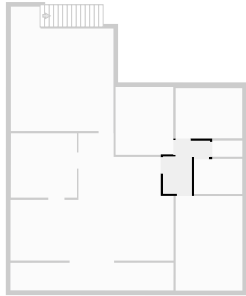

▼ **Bedroom**
1st Floor

WIDTH: 3.60 m • LENGTH: 5.10 m
AREA: 18.36 m² • PERIMETER: 17.40 m

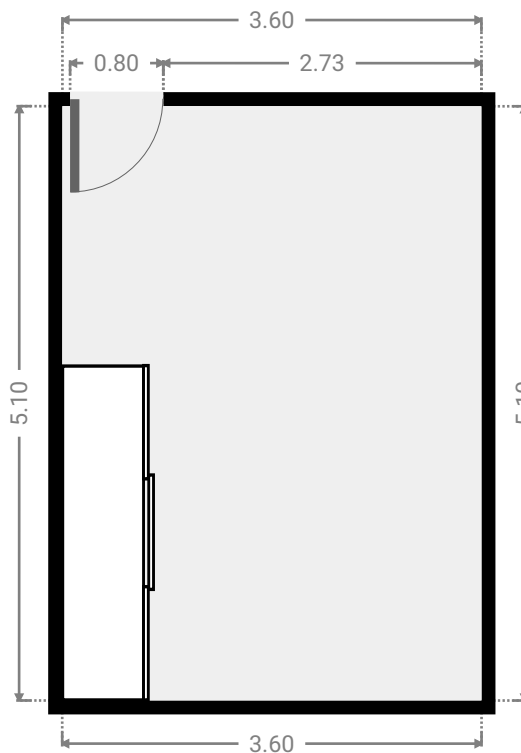
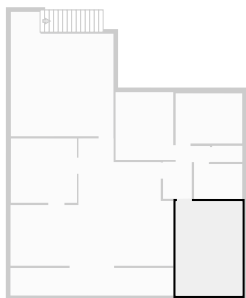

▼ **Bedroom**
1st Floor

WIDTH: 3.11 m • LENGTH: 3.66 m
AREA: 11.38 m² • PERIMETER: 13.54 m

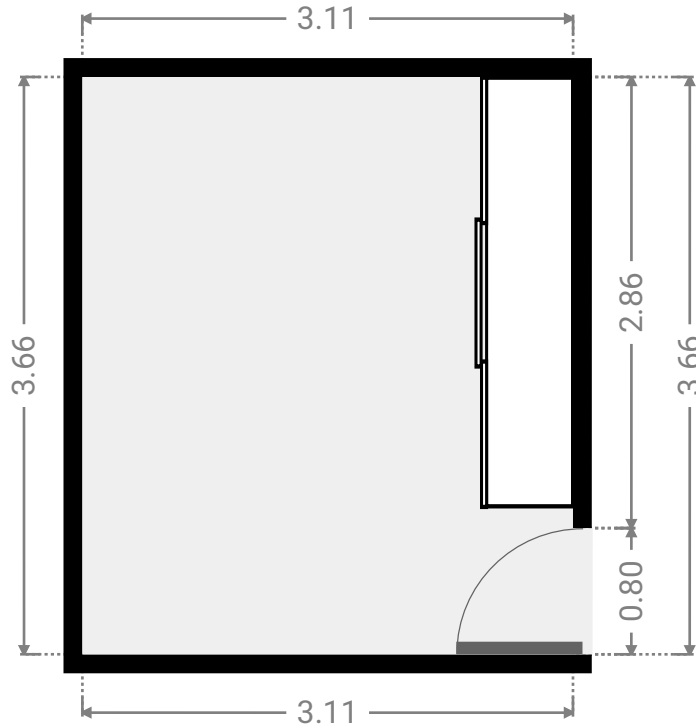
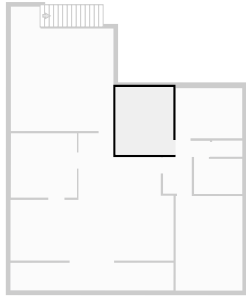

▼ **Bedroom**
1st Floor

WIDTH: 3.59 m • LENGTH: 2.70 m
AREA: 9.70 m² • PERIMETER: 12.58 m

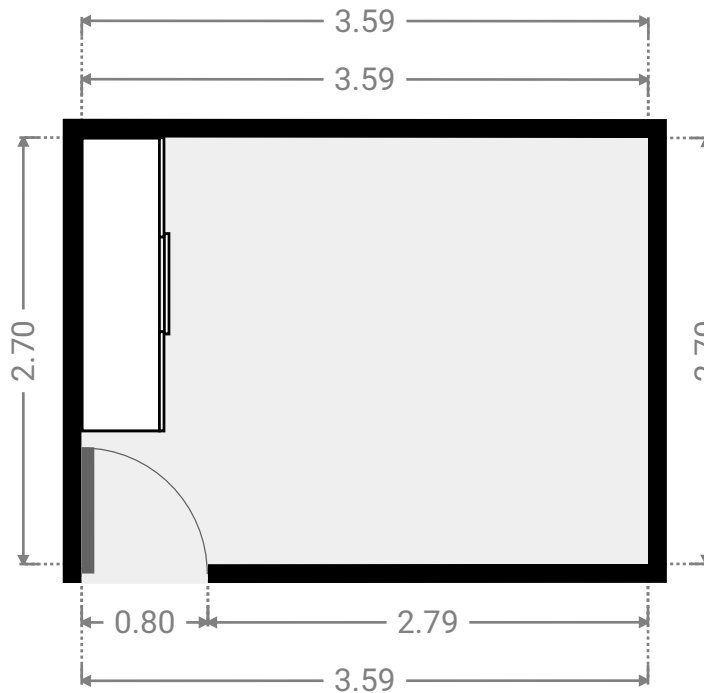
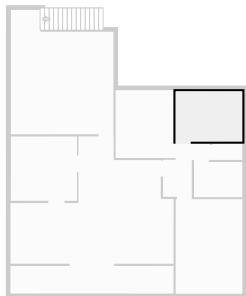

▼ **Toilet**
1st Floor

WIDTH: 1.63 m • LENGTH: 0.87 m
AREA: 1.41 m² • PERIMETER: 4.99 m

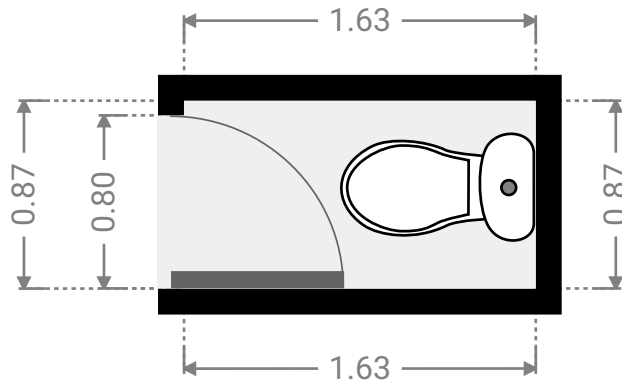
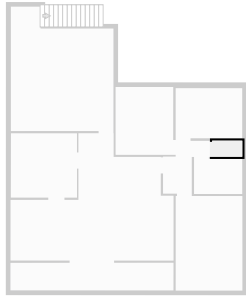

▼ **Bathroom**
1st Floor

WIDTH: 2.60 m • LENGTH: 1.90 m
AREA: 4.94 m² • PERIMETER: 9.00 m

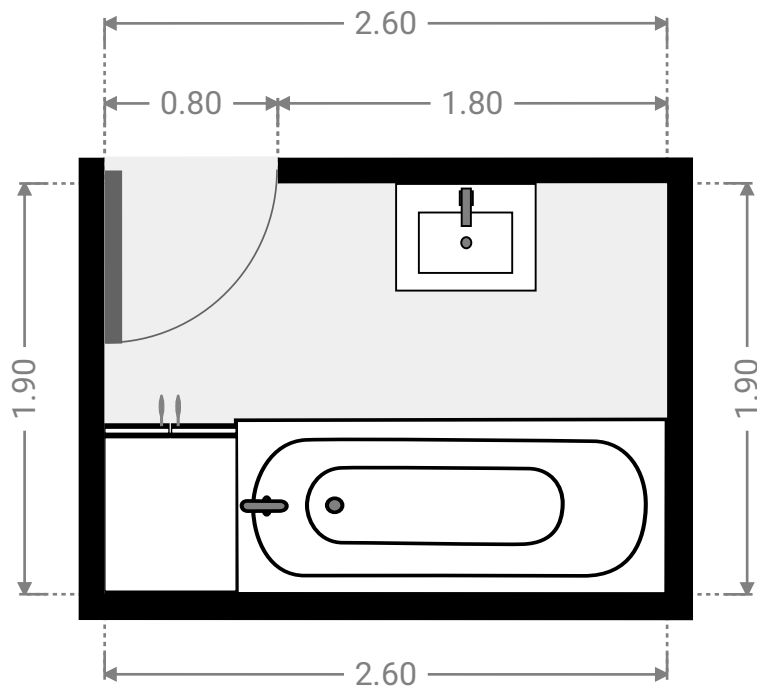
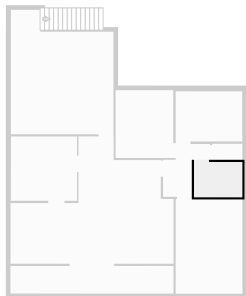

▼ Other
1st Floor

WIDTH: 8.80 m • LENGTH: 1.49 m
AREA: 13.09 m² • PERIMETER: 20.57 m

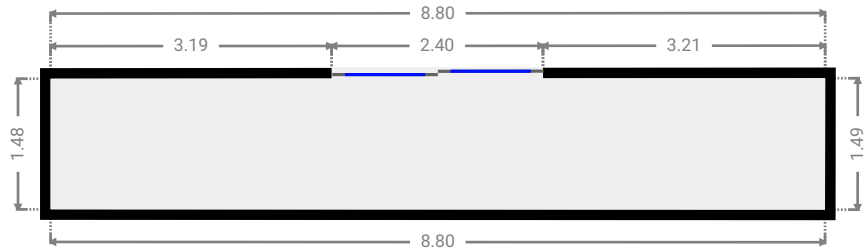
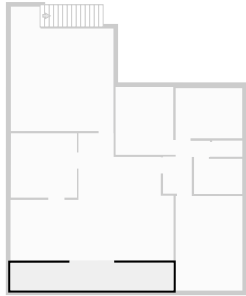

▼ Other
1st Floor

WIDTH: 5.54 m • LENGTH: 6.71 m
AREA: 32.50 m² • PERIMETER: 24.49 m

