

9 Macnevin Street

SUBMITTED BY

Ray White Rockhampton Casey
stockers@cqoz.com

CREATED ON

2022-01-12

Floors

2

▼ Ground Floor

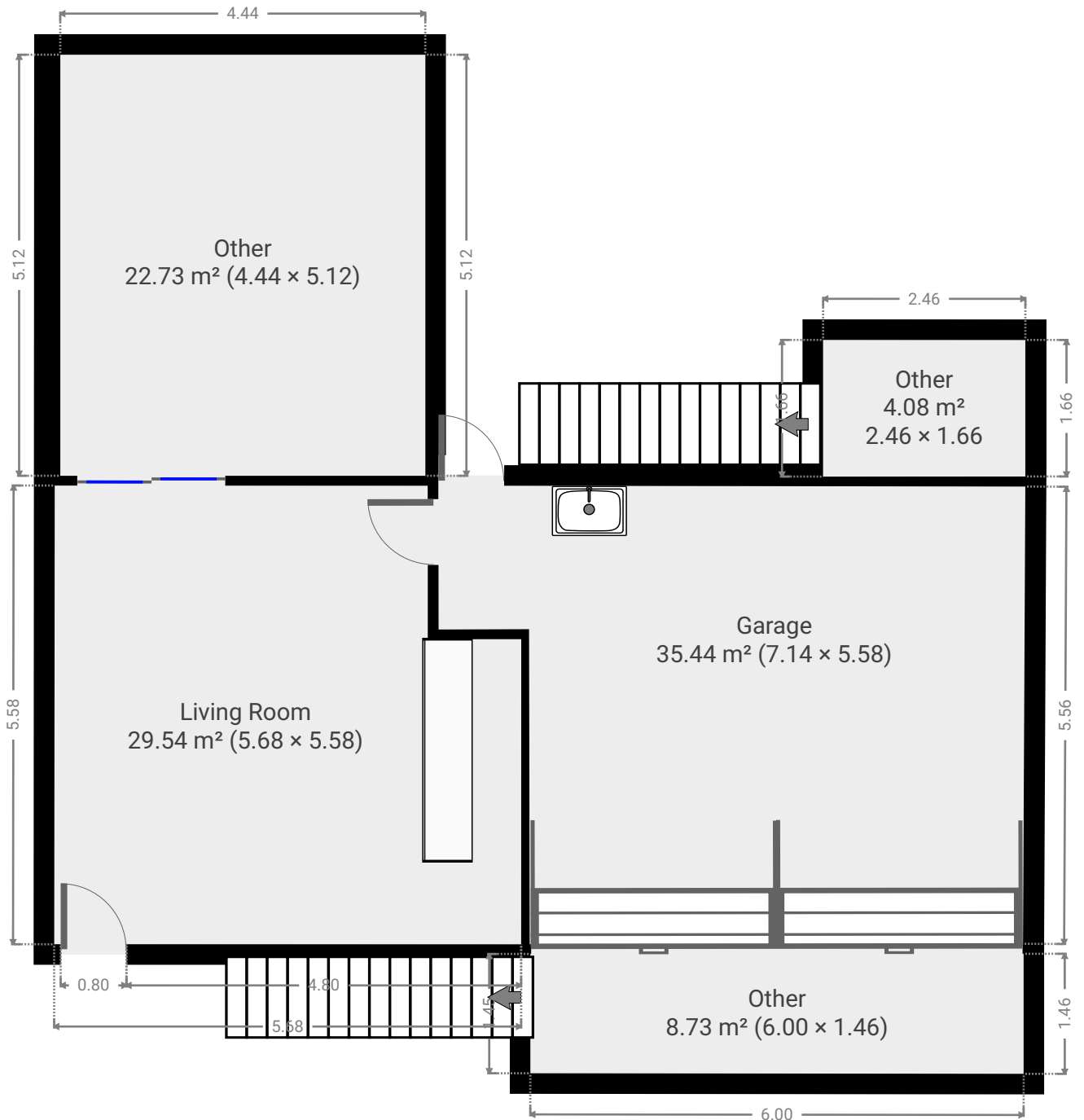

▼ Garage
Ground Floor

WIDTH: 7.14 m • LENGTH: 5.56 m
AREA: 35.44 m² • PERIMETER: 25.38 m

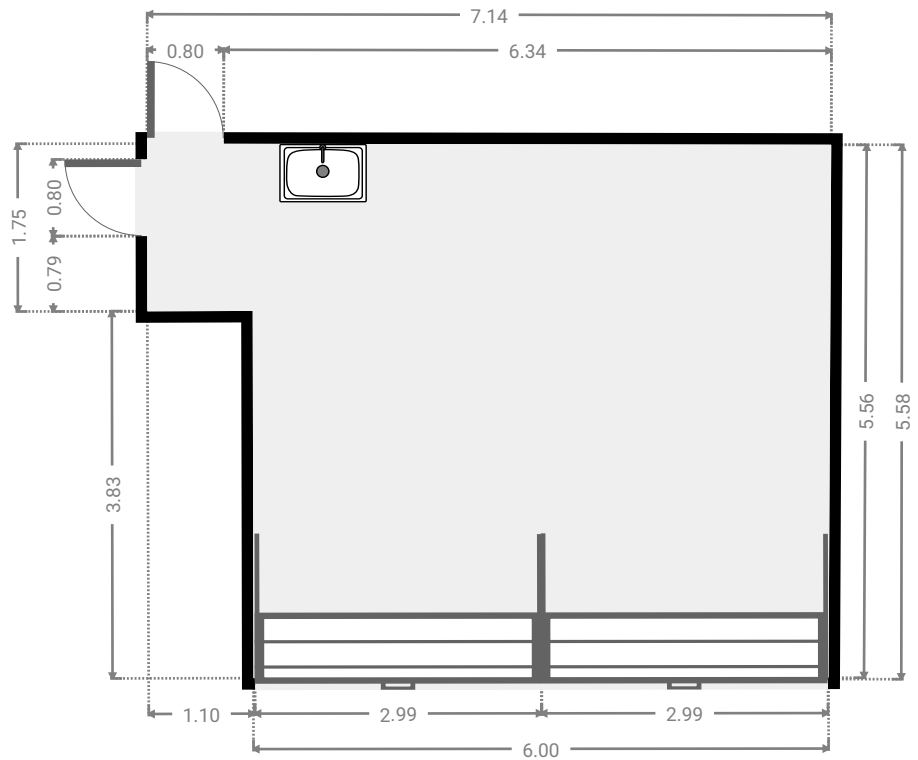
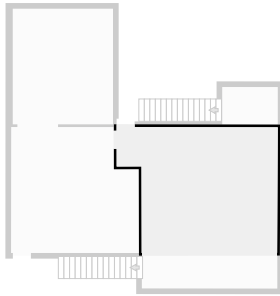

▼ Living Room
Ground Floor

WIDTH: 5.68 m • LENGTH: 5.56 m
AREA: 29.54 m² • PERIMETER: 22.51 m

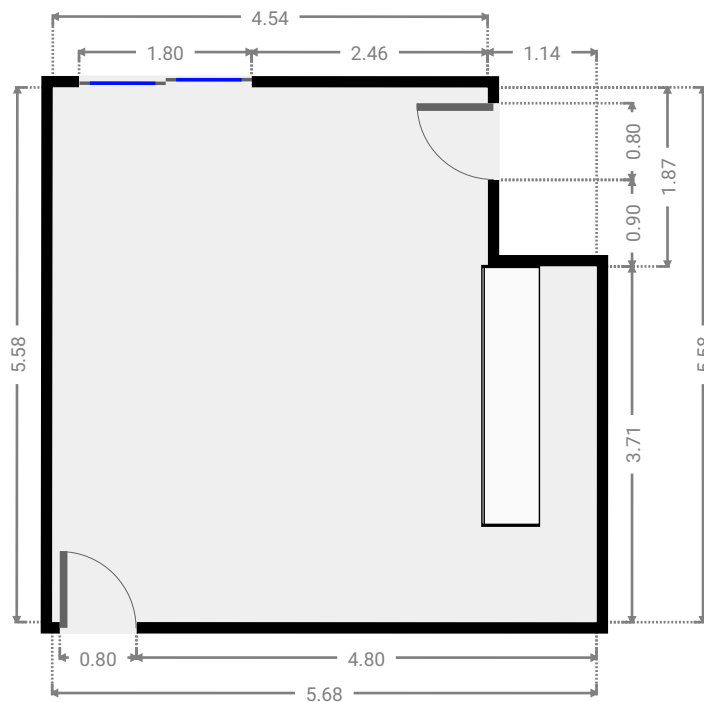
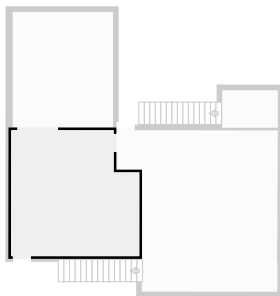

▼ Other
Ground Floor

WIDTH: 4.44 m • LENGTH: 5.12 m
AREA: 22.73 m² • PERIMETER: 19.12 m

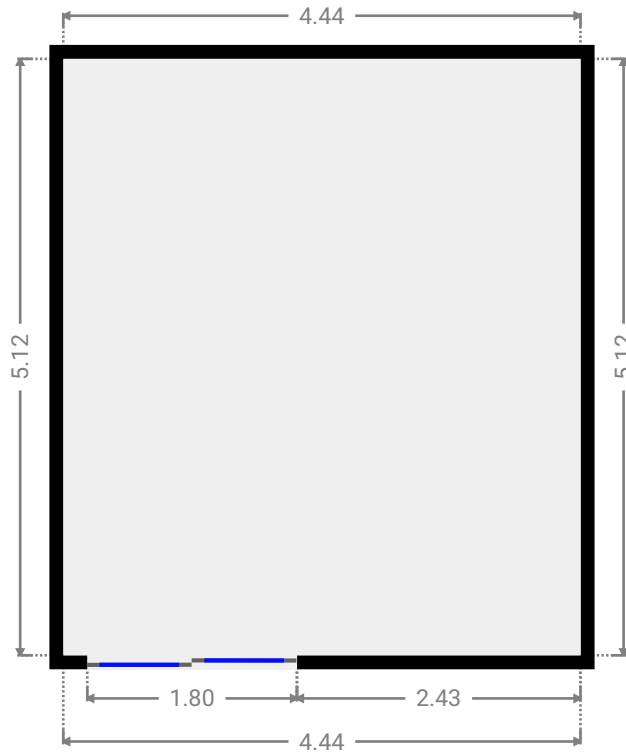
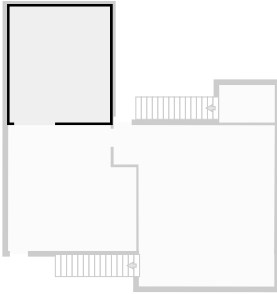

▼ Other
Ground Floor

WIDTH: 2.46 m • LENGTH: 1.66 m
AREA: 4.08 m² • PERIMETER: 8.24 m

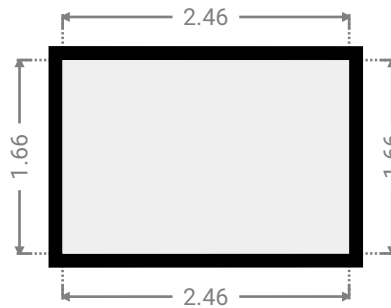
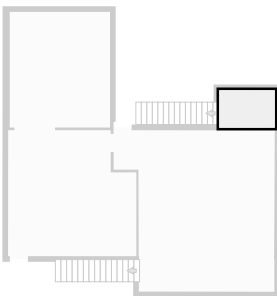

▼ Other
Ground Floor

WIDTH: 6.00 m • LENGTH: 1.46 m
AREA: 8.73 m² • PERIMETER: 14.91 m

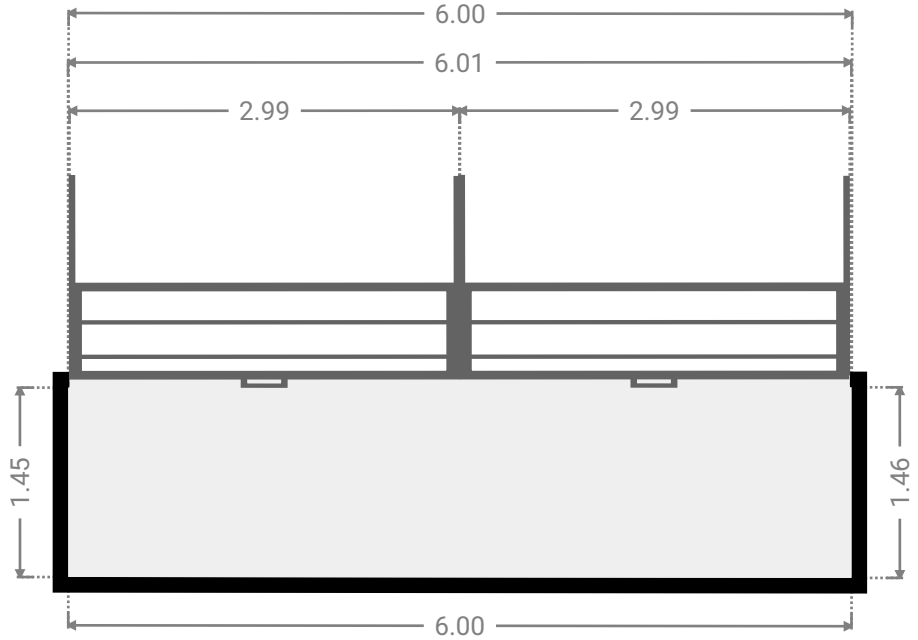
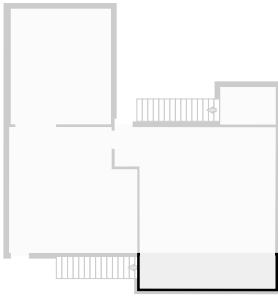

▼ 1st Floor

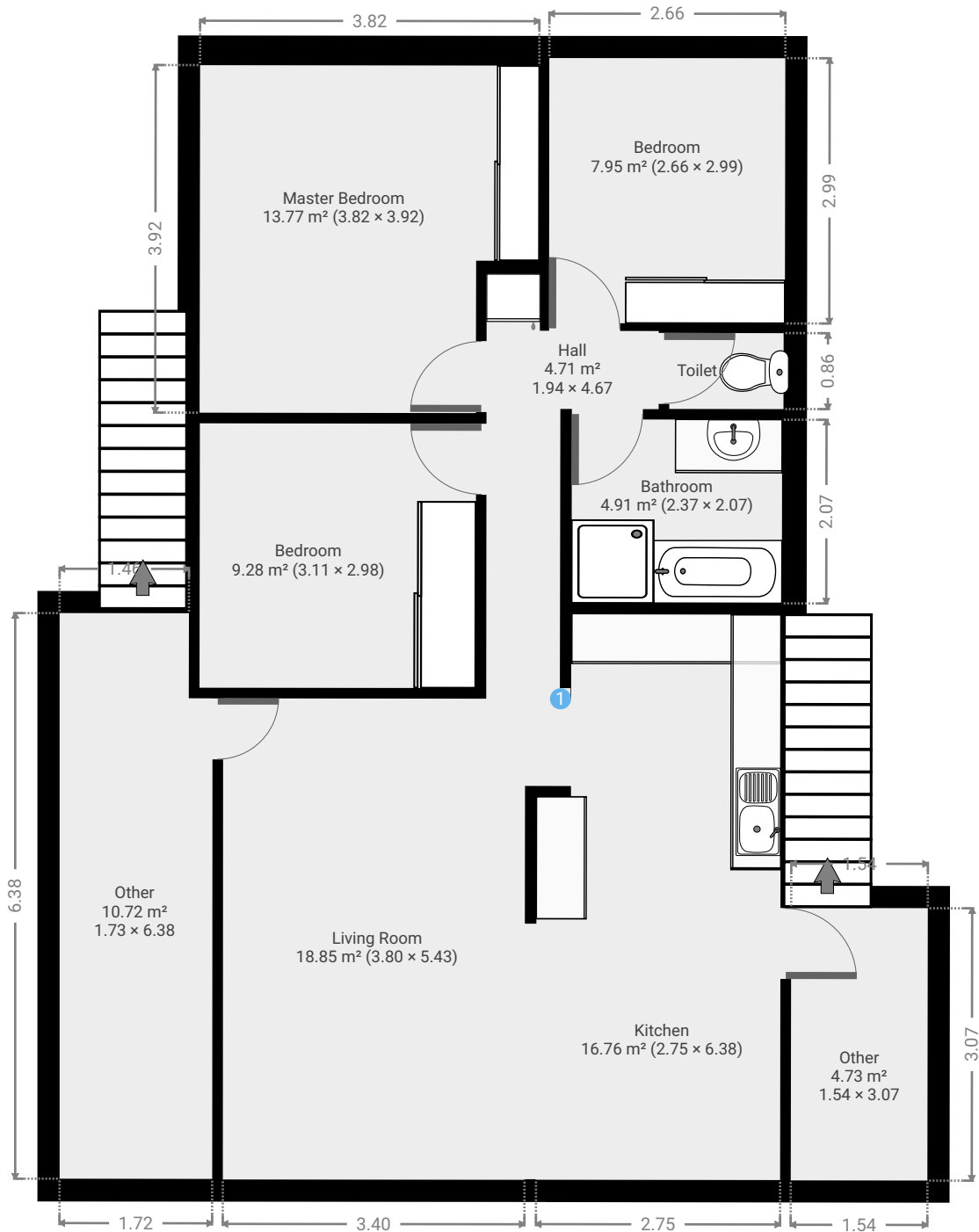

▼ **Living Room**
1st Floor

WIDTH: 5.43 m • LENGTH: 3.80 m
AREA: 18.85 m² • PERIMETER: 18.45 m

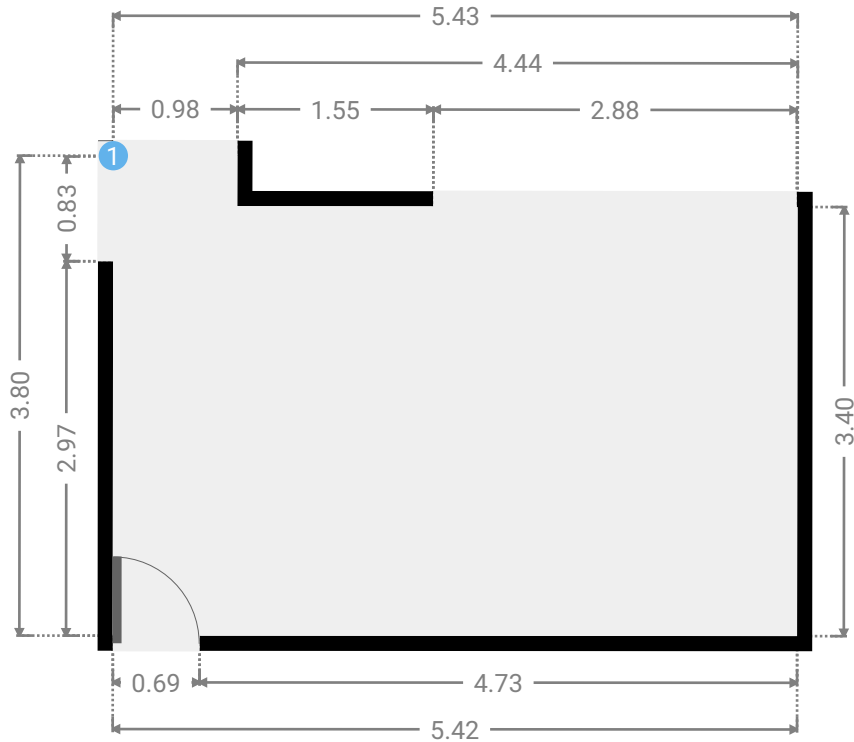
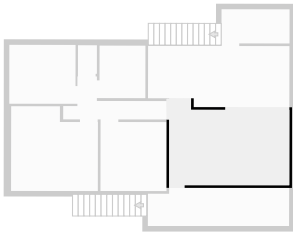

▼ **Living Room/1st Floor**

1 OPENING

Height
0.00 m



▼ Kitchen
1st Floor

WIDTH: 6.38 m • LENGTH: 2.75 m
AREA: 16.76 m² • PERIMETER: 18.26 m

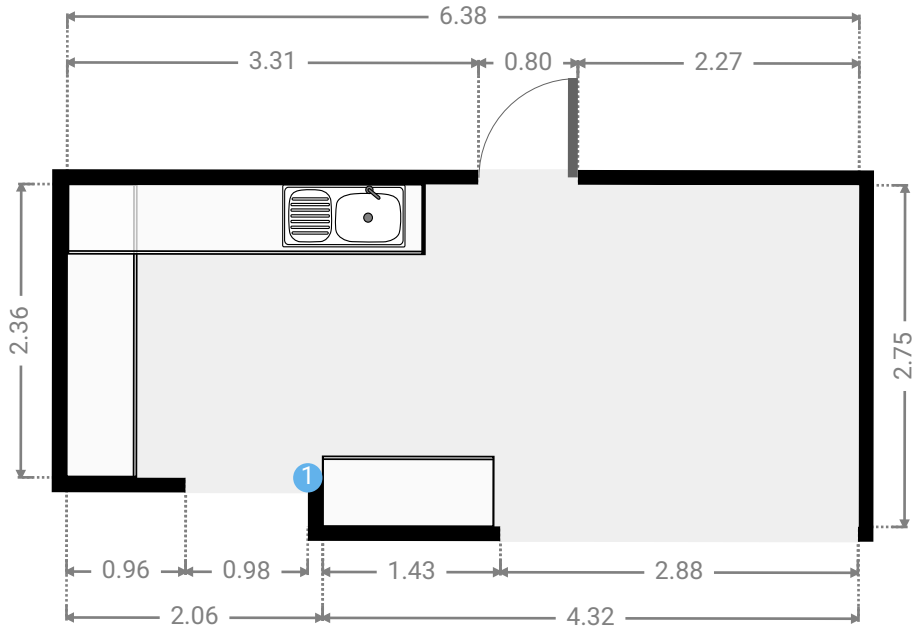
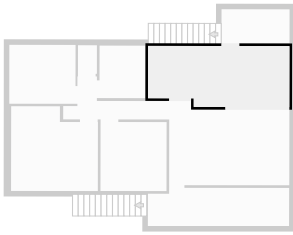

▼ Other
1st Floor

WIDTH: 3.07 m • LENGTH: 1.54 m
AREA: 4.73 m² • PERIMETER: 9.22 m

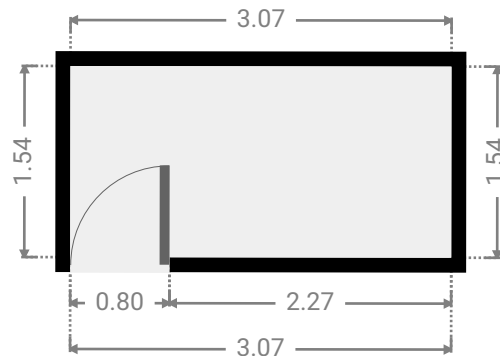
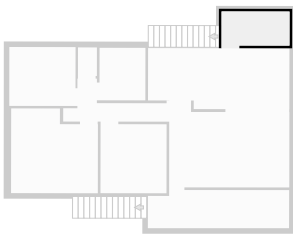

▼ **Hall**
1st Floor

WIDTH: 4.67 m • LENGTH: 1.94 m
AREA: 4.71 m² • PERIMETER: 13.21 m

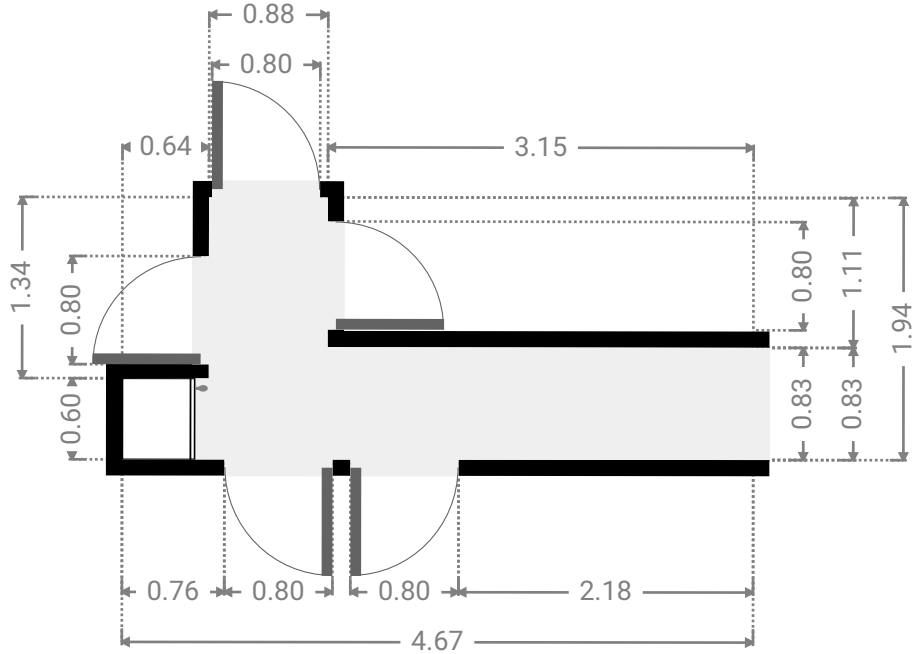
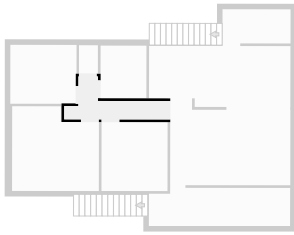

▼ **Bedroom**
1st Floor

WIDTH: 2.98 m • LENGTH: 3.11 m
AREA: 9.28 m² • PERIMETER: 12.19 m

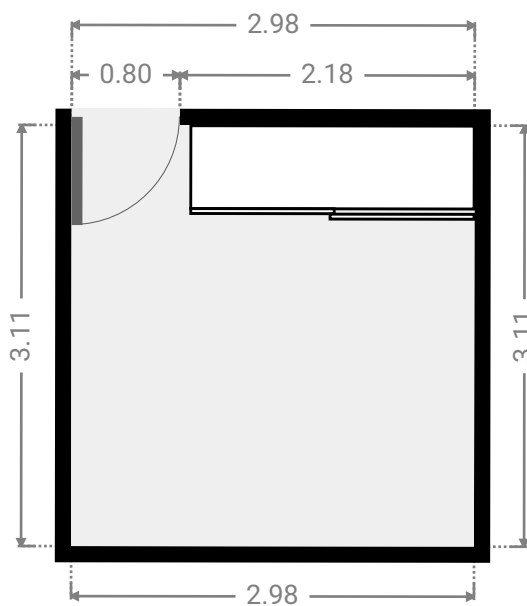
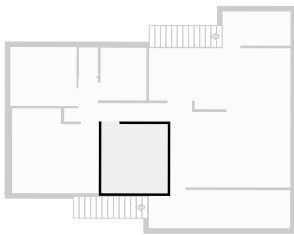

▼ Bathroom
1st Floor

WIDTH: 2.07 m • LENGTH: 2.37 m
AREA: 4.91 m² • PERIMETER: 8.88 m

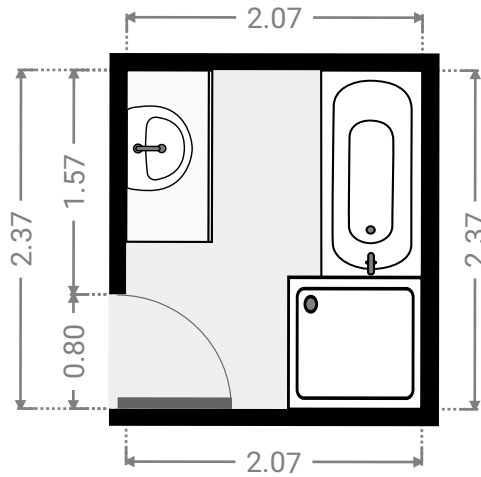
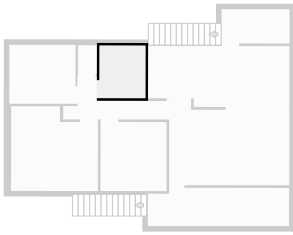

▼ Master Bedroom
1st Floor

WIDTH: 3.92 m • LENGTH: 3.82 m
AREA: 13.77 m² • PERIMETER: 15.48 m

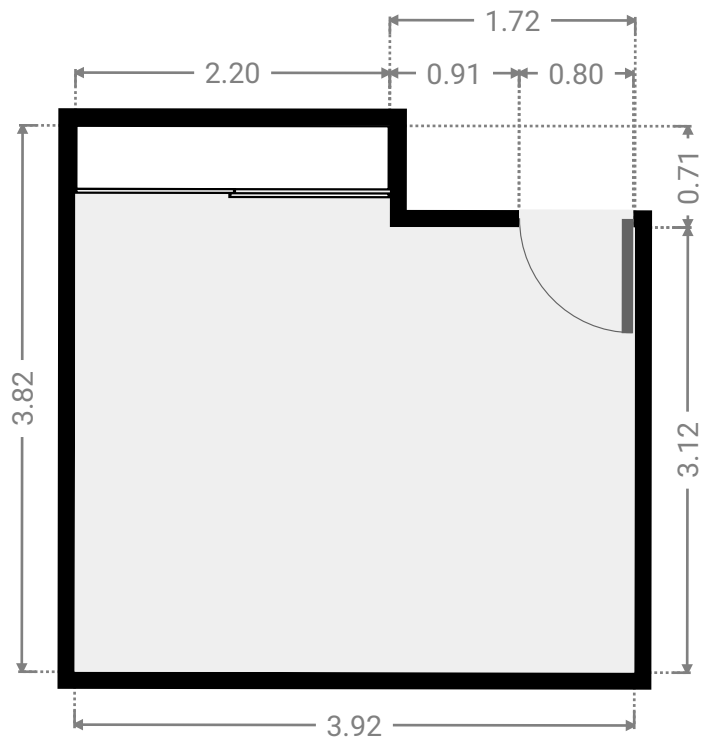
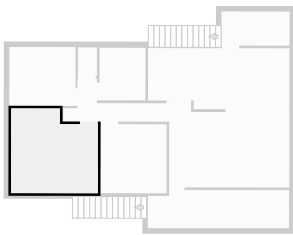

▼ **Bedroom**
1st Floor

WIDTH: 2.99 m • LENGTH: 2.66 m
AREA: 7.95 m² • PERIMETER: 11.29 m

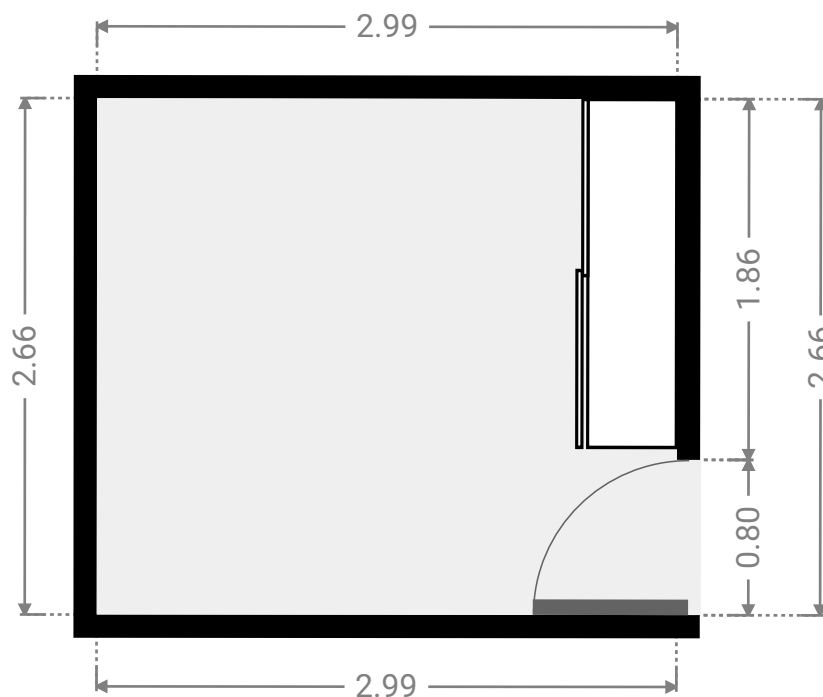
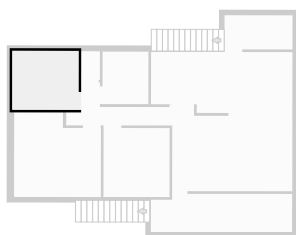

▼ **Toilet**
1st Floor

WIDTH: 0.86 m • LENGTH: 1.29 m
AREA: 1.10 m² • PERIMETER: 4.29 m

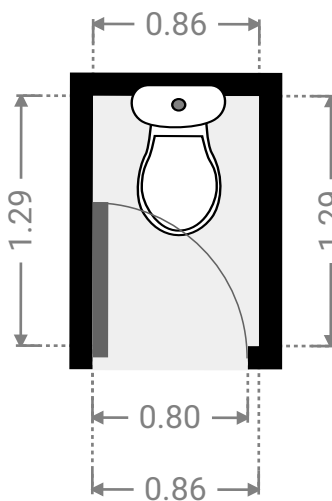
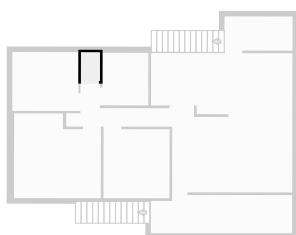

▼ Other
1st Floor

WIDTH: 6.38 m • LENGTH: 1.73 m
AREA: 10.72 m² • PERIMETER: 16.20 m

