

9 Macgregor Street

Prepared by
11 Fenwick Street

Created on
2021-08-11

Floors
2

▼ Ground Floor

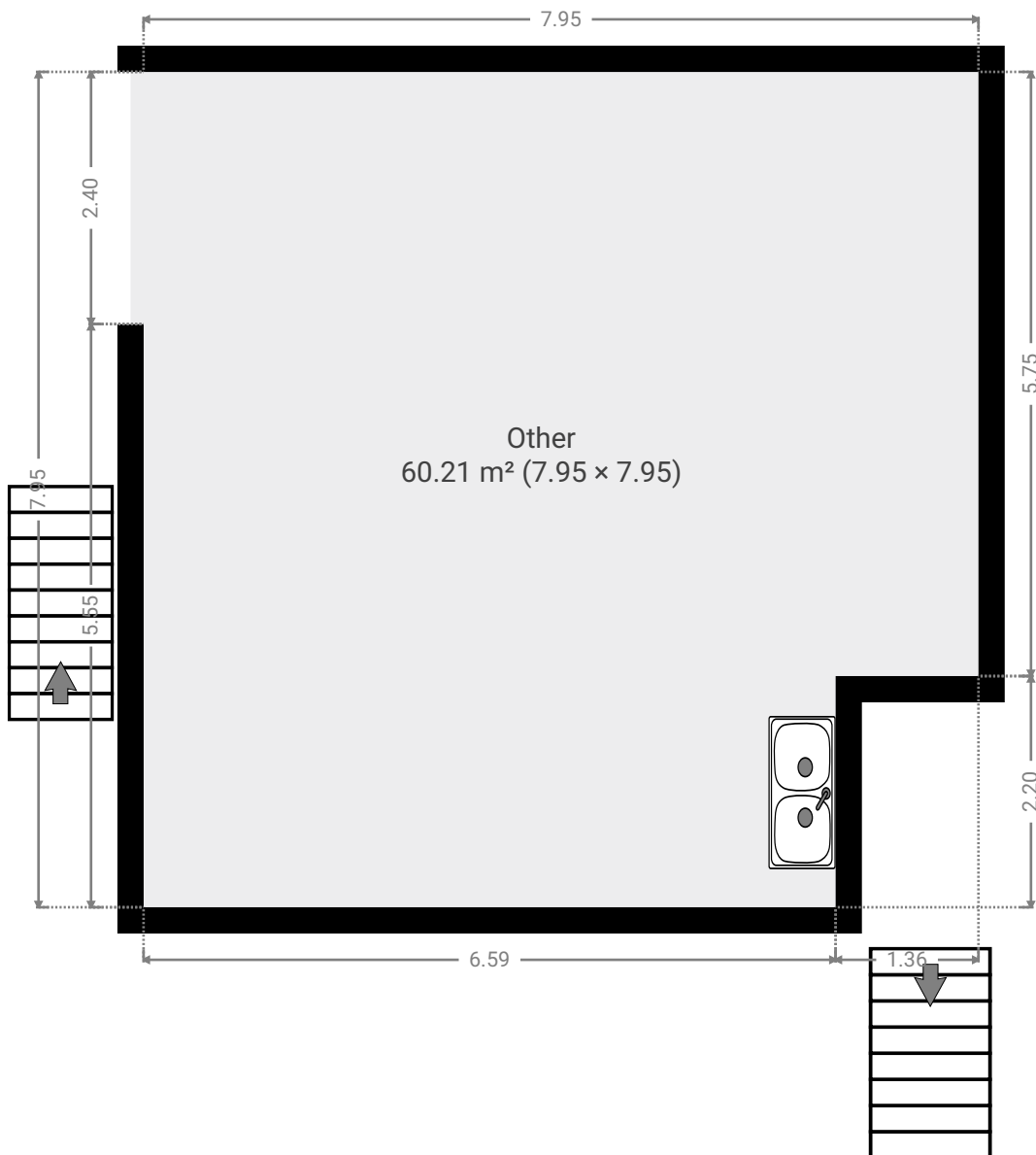

▼ Other
Ground Floor

WIDTH: 7.95 m • LENGTH: 7.95 m
AREA: 60.21 m² • PERIMETER: 31.80 m

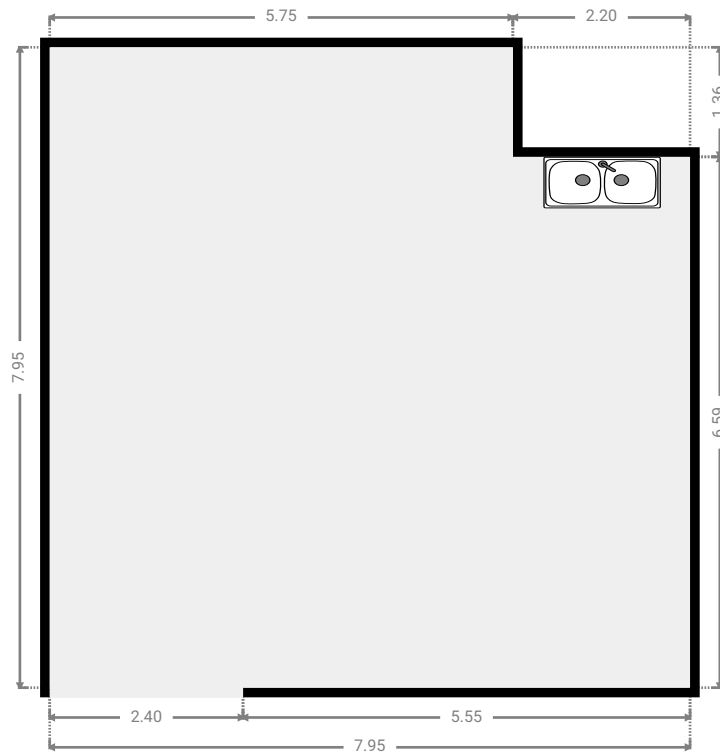
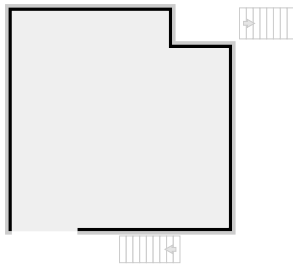

▼ 1st Floor

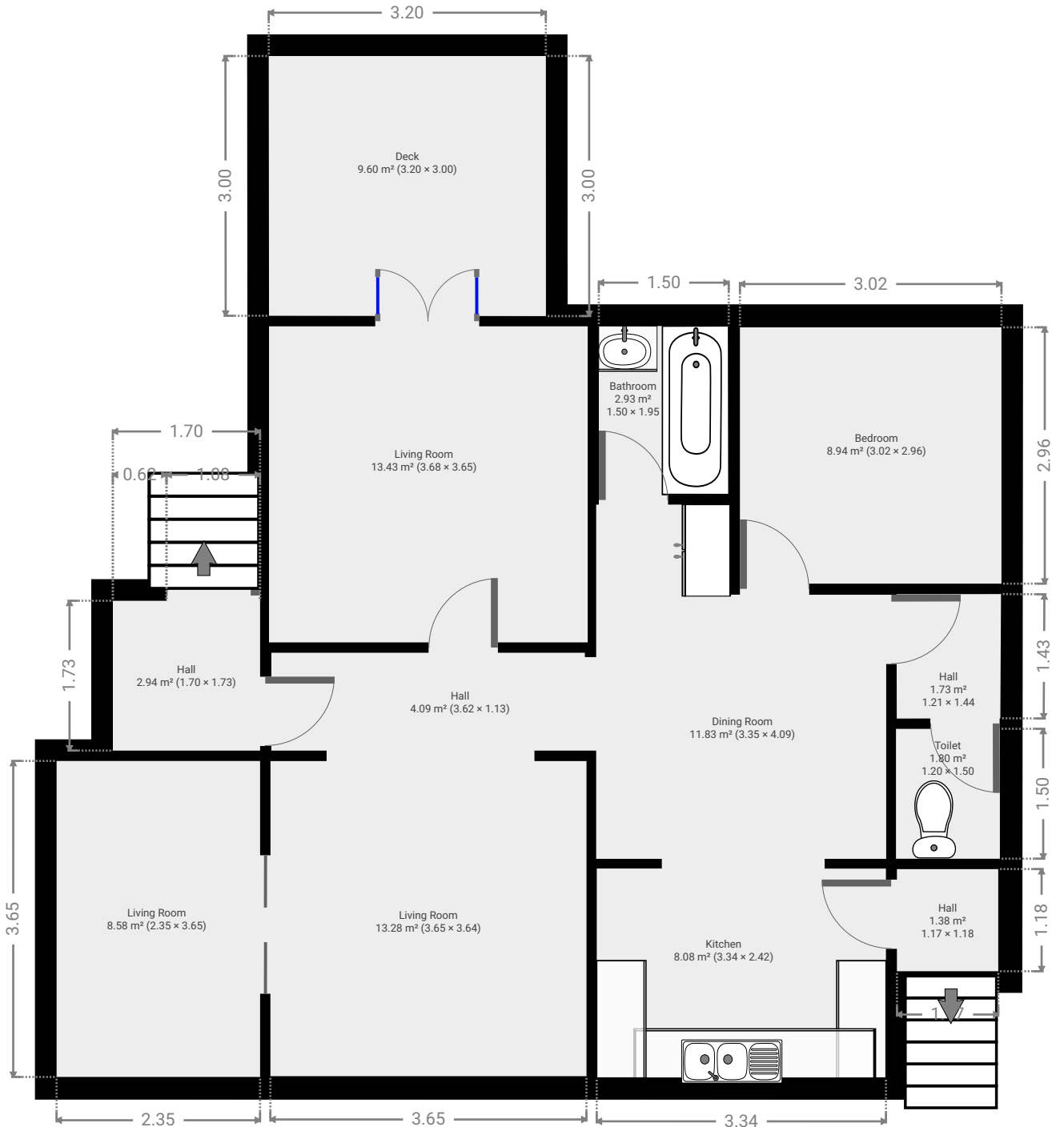

▼ Hall
1st Floor

WIDTH: 1.73 m • LENGTH: 1.70 m
AREA: 2.94 m² • PERIMETER: 6.86 m

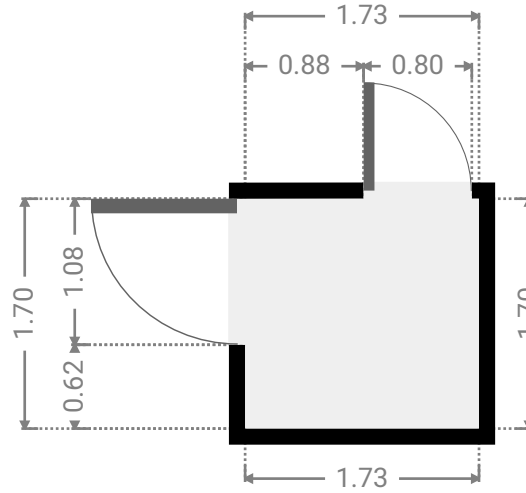
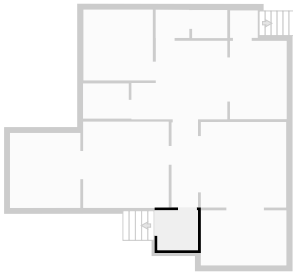

▼ Hall
1st Floor

WIDTH: 1.13 m • LENGTH: 3.62 m
AREA: 4.09 m² • PERIMETER: 9.50 m

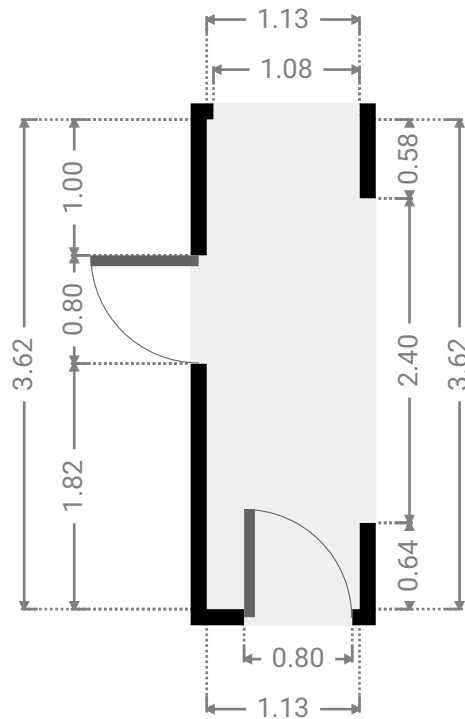
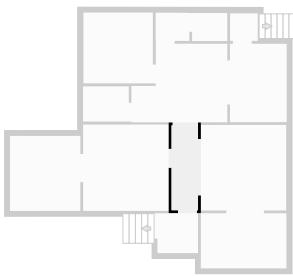

▼ Living Room
1st Floor

WIDTH: 3.64 m • LENGTH: 3.65 m
AREA: 13.28 m² • PERIMETER: 14.58 m

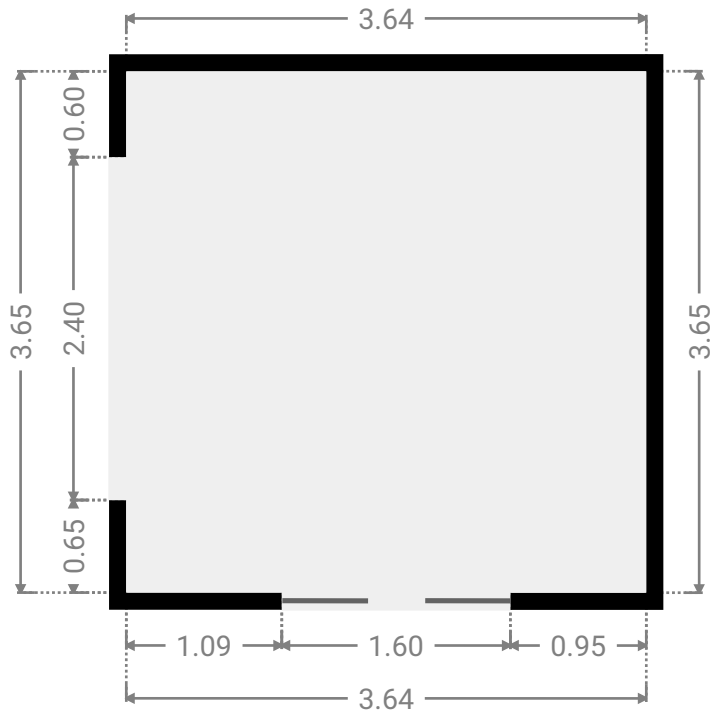
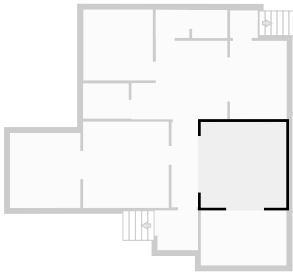

▼ Living Room
1st Floor

WIDTH: 3.65 m • LENGTH: 2.35 m
AREA: 8.58 m² • PERIMETER: 12.00 m

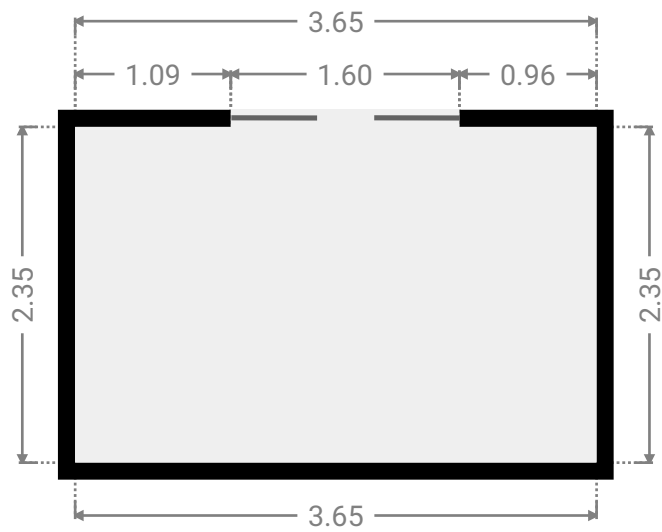
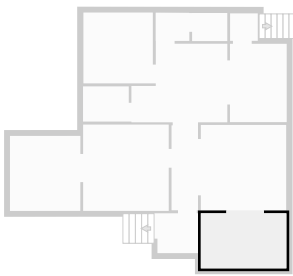

▼ Living Room
1st Floor

WIDTH: 3.65 m • LENGTH: 3.68 m
AREA: 13.43 m² • PERIMETER: 14.66 m

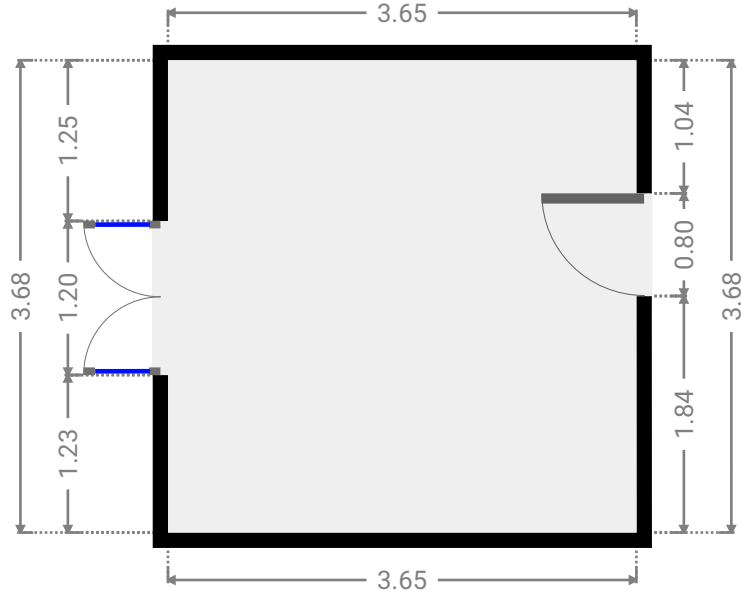
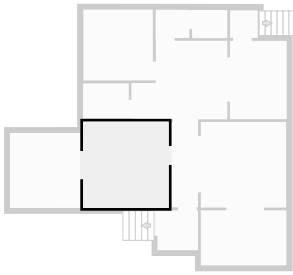

▼ Dining Room
1st Floor

WIDTH: 4.09 m • LENGTH: 3.35 m
AREA: 11.83 m² • PERIMETER: 14.88 m

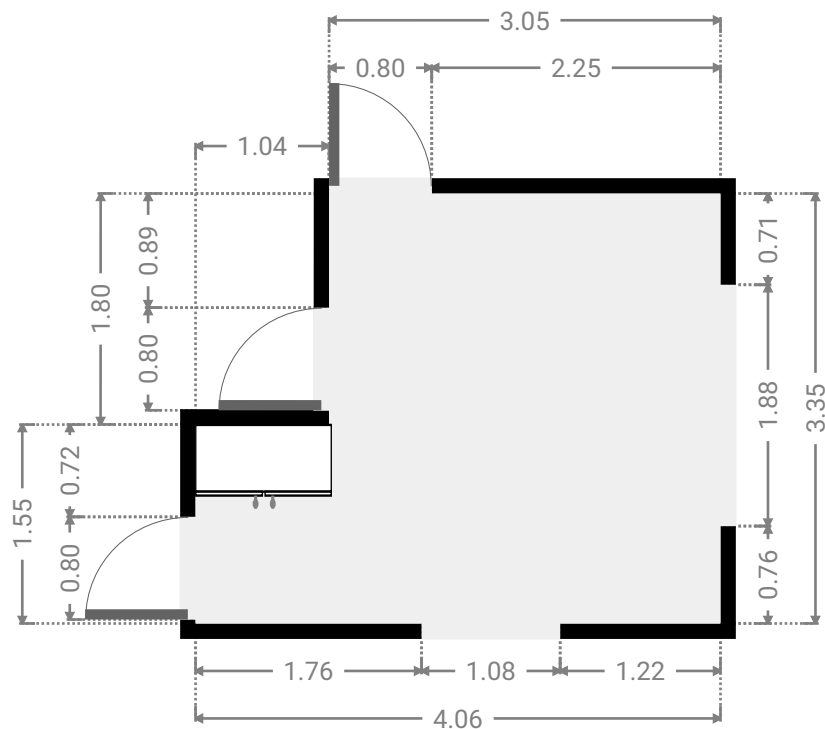
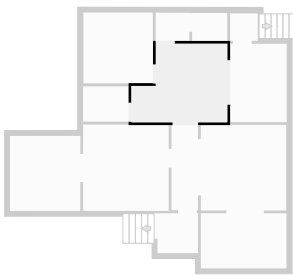

▼ **Bathroom**
1st Floor

WIDTH: 1.95 m • LENGTH: 1.50 m
AREA: 2.93 m² • PERIMETER: 6.90 m

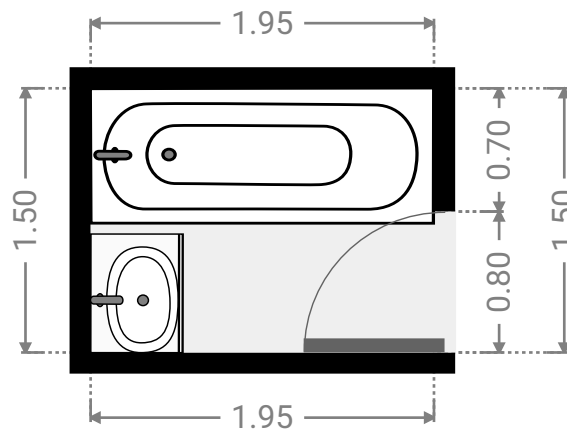
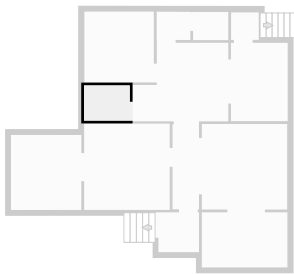

▼ **Bedroom**
1st Floor

WIDTH: 2.96 m • LENGTH: 3.02 m
AREA: 8.94 m² • PERIMETER: 11.96 m

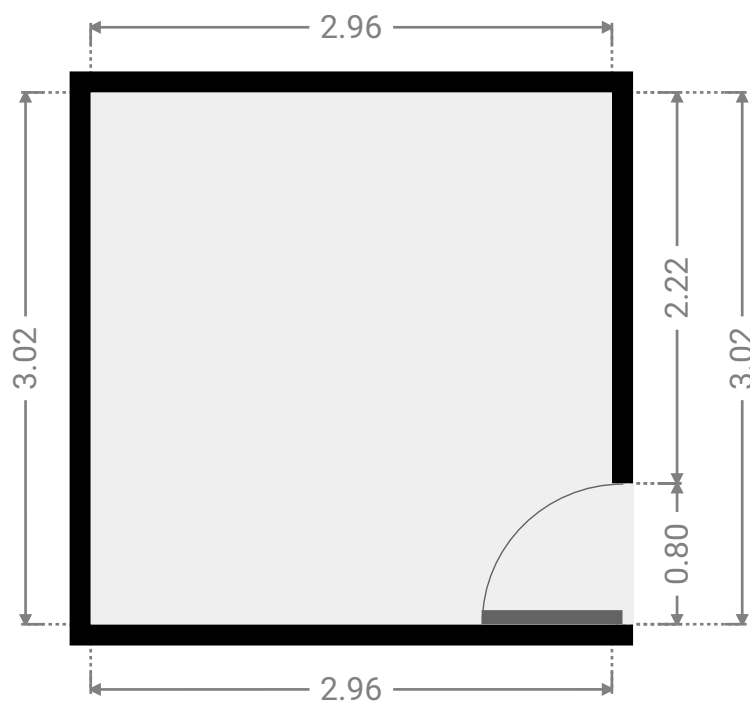
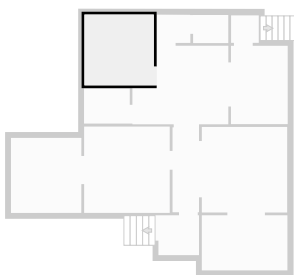

▼ Kitchen
1st Floor

WIDTH: 2.42 m • LENGTH: 3.34 m
AREA: 8.08 m² • PERIMETER: 11.52 m

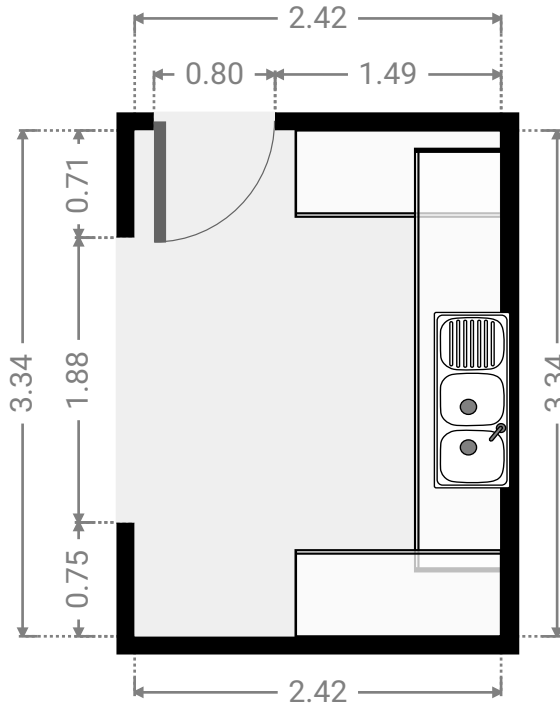
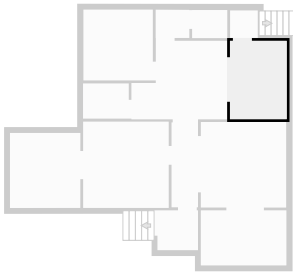

▼ Hall
1st Floor

WIDTH: 1.18 m • LENGTH: 1.17 m
AREA: 1.38 m² • PERIMETER: 4.70 m

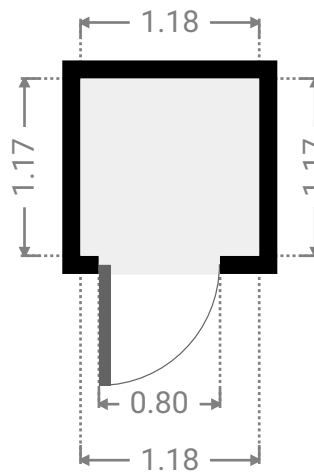
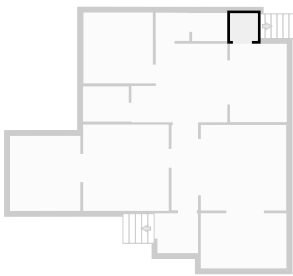

▼ Toilet
1st Floor

WIDTH: 1.50 m • LENGTH: 1.20 m
AREA: 1.80 m² • PERIMETER: 5.40 m

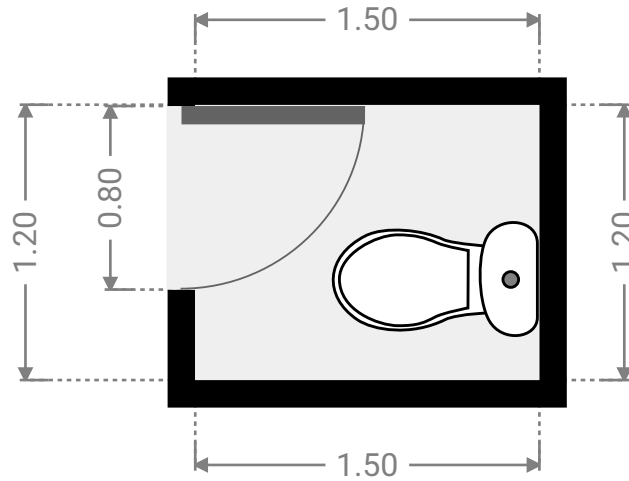
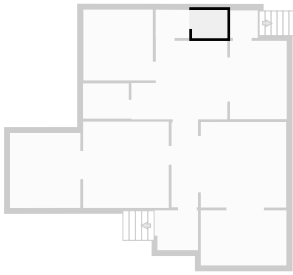

▼ Hall
1st Floor

WIDTH: 1.44 m • LENGTH: 1.21 m
AREA: 1.73 m² • PERIMETER: 5.28 m

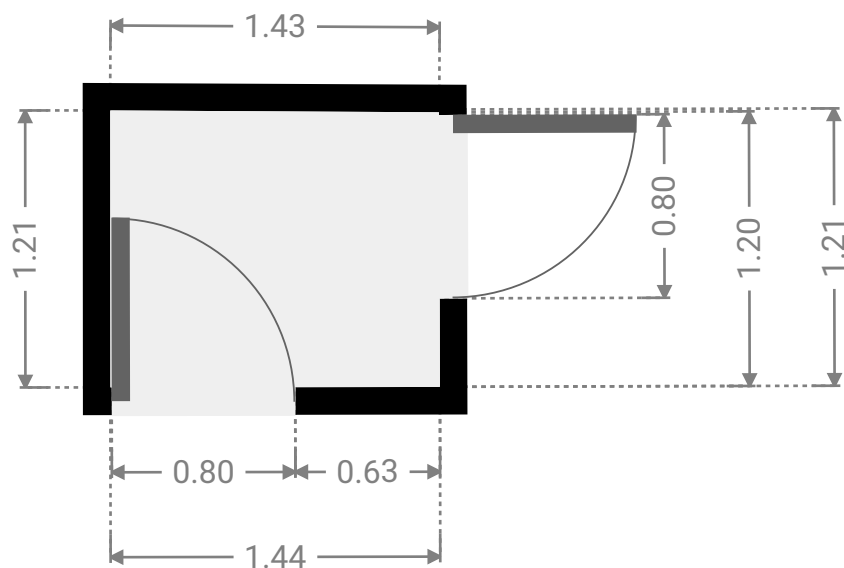
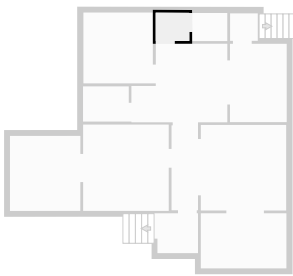

▼ Deck
1st Floor

WIDTH: 3.00 m • LENGTH: 3.20 m
AREA: 9.60 m² • PERIMETER: 12.40 m

