

88 Stenlake Avenue

Created on
2021-07-13

Floors
2

▼ Ground Floor

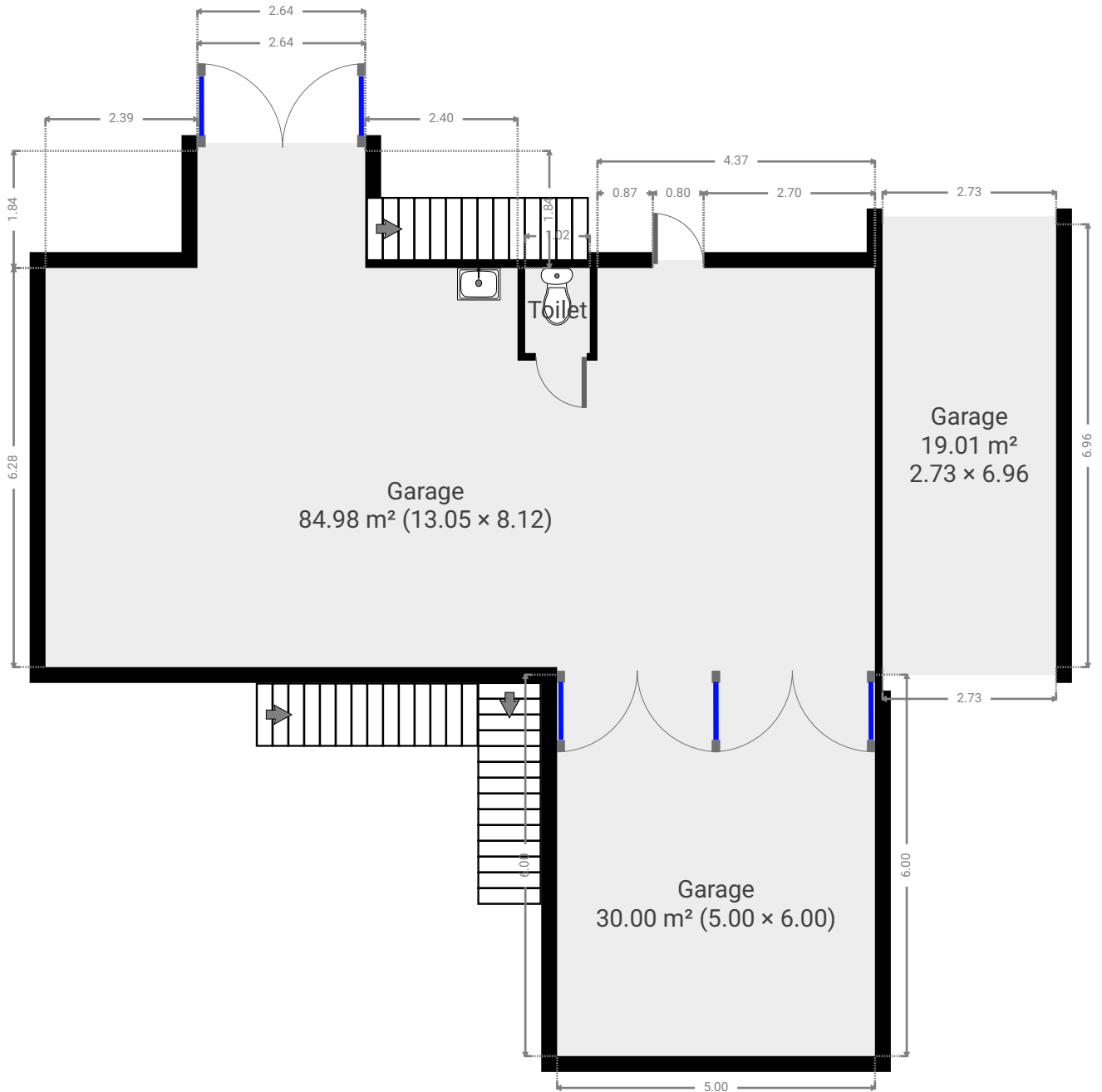

▼ Garage
Ground Floor

WIDTH: 13.05 m • LENGTH: 8.12 m
AREA: 84.98 m² • PERIMETER: 45.26 m

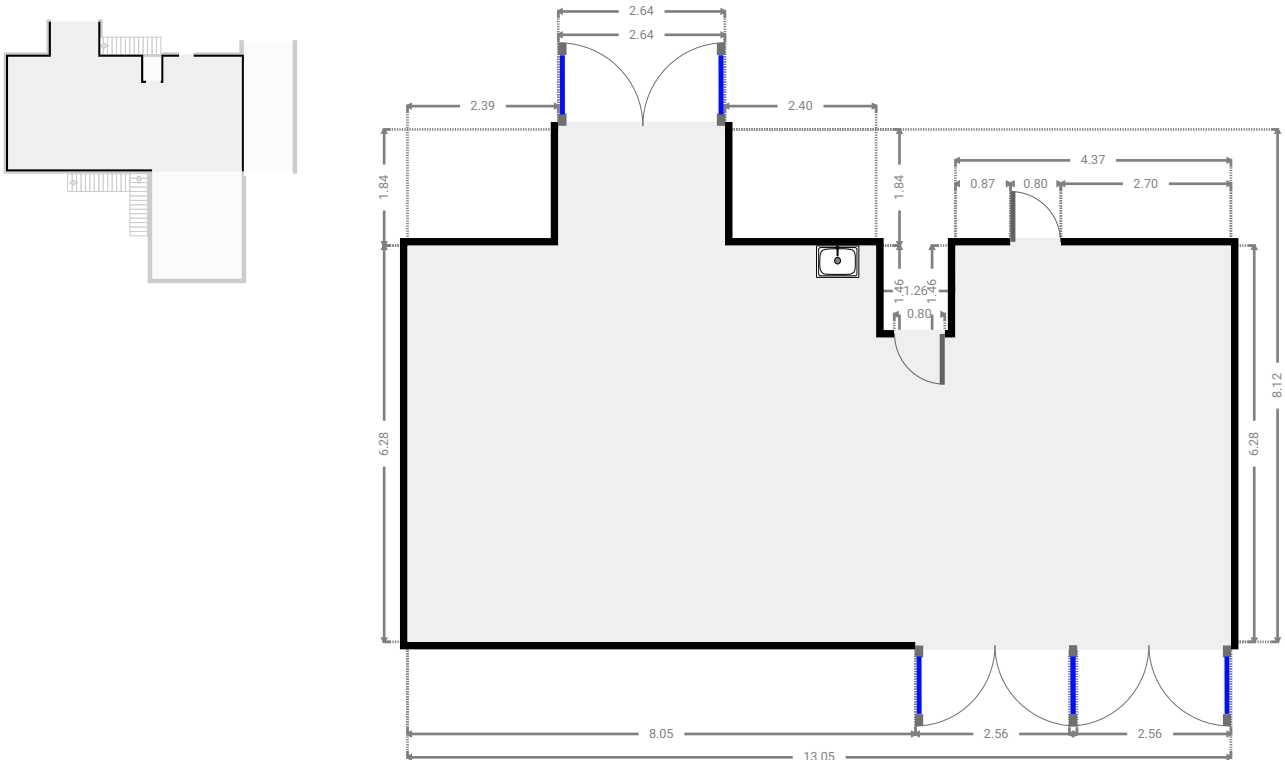

▼ Garage
Ground Floor

WIDTH: 5.00 m • LENGTH: 6.00 m
AREA: 30.00 m² • PERIMETER: 22.00 m

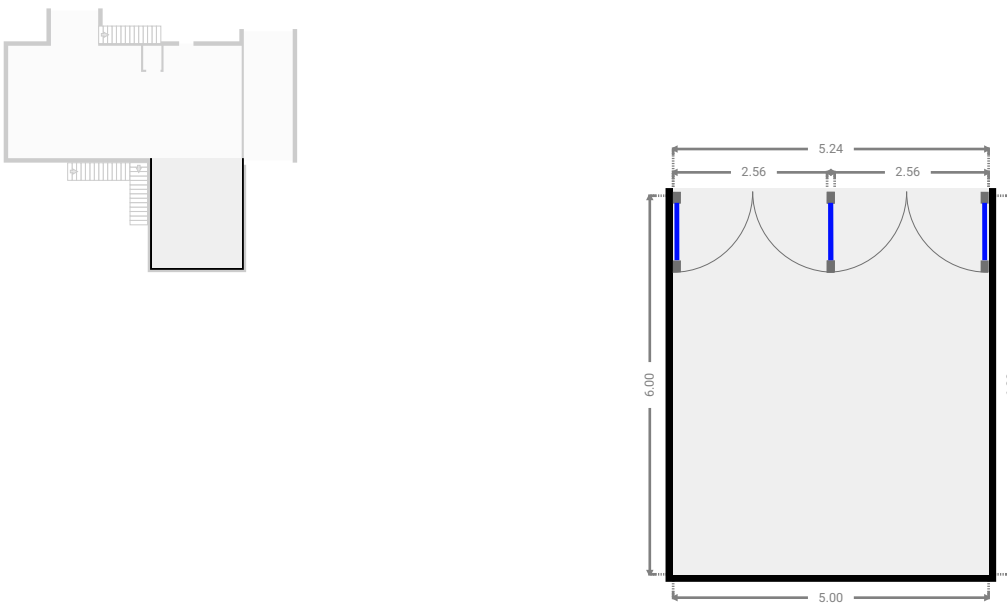

▼ **Garage**
Ground Floor

WIDTH: 2.73 m • LENGTH: 6.96 m
AREA: 19.01 m² • PERIMETER: 19.39 m

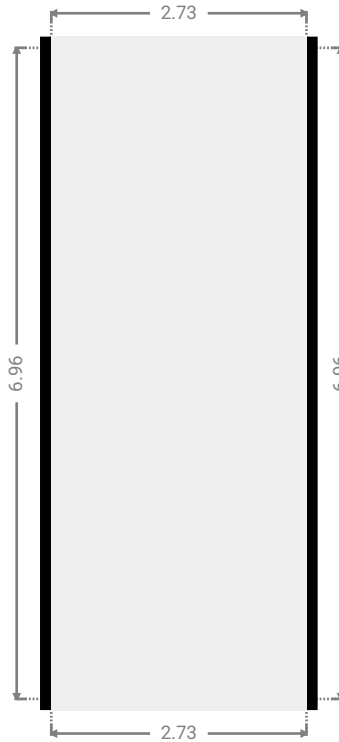
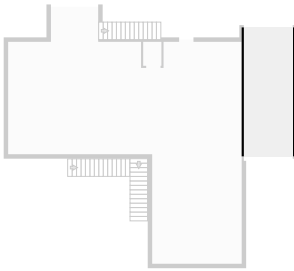

▼ **Toilet**
Ground Floor

WIDTH: 1.02 m • LENGTH: 1.34 m
AREA: 1.36 m² • PERIMETER: 4.71 m

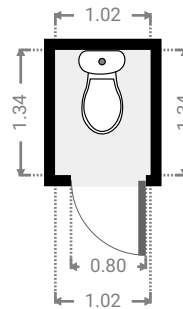
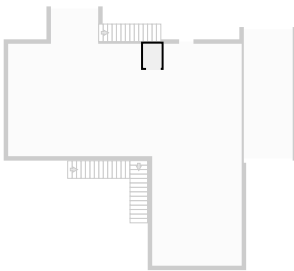

▼ 1st Floor

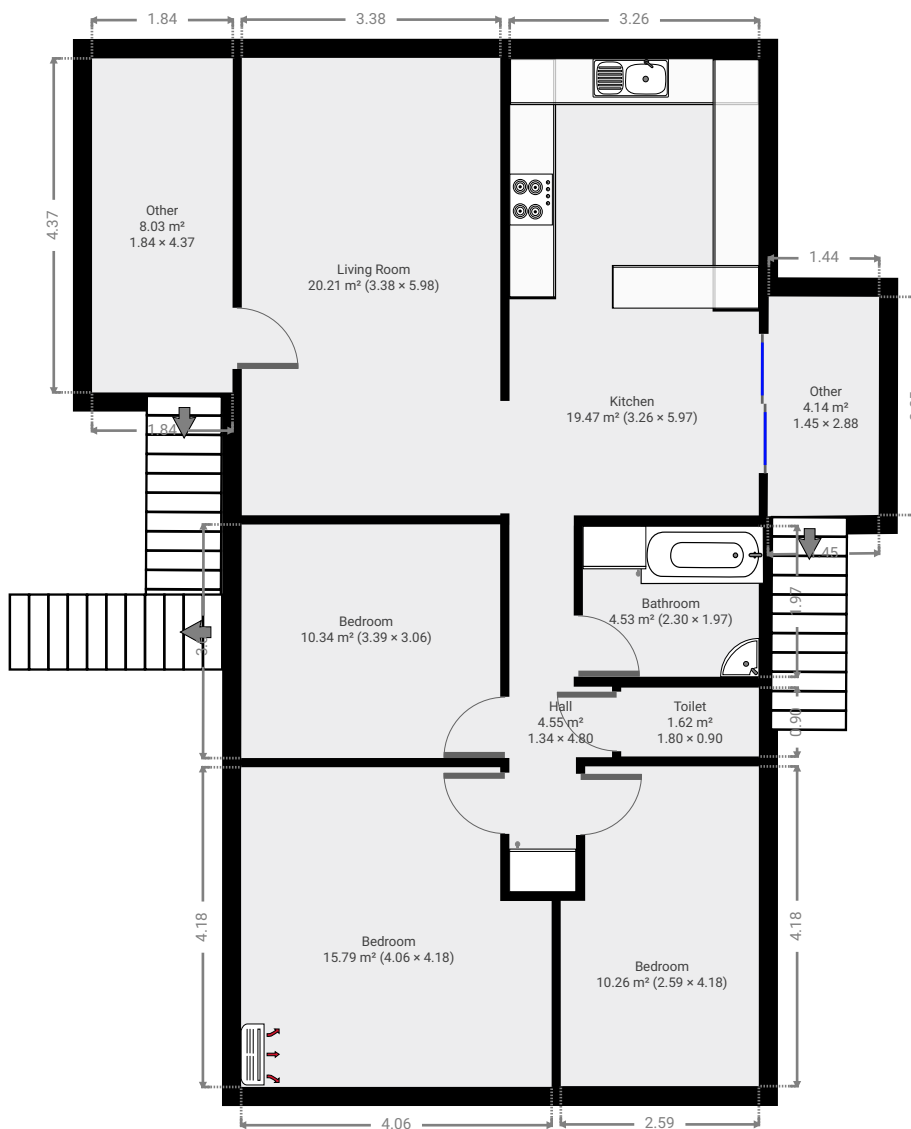

▼ Living Room
1st Floor

WIDTH: 5.98 m • LENGTH: 3.38 m
AREA: 20.21 m² • PERIMETER: 18.72 m

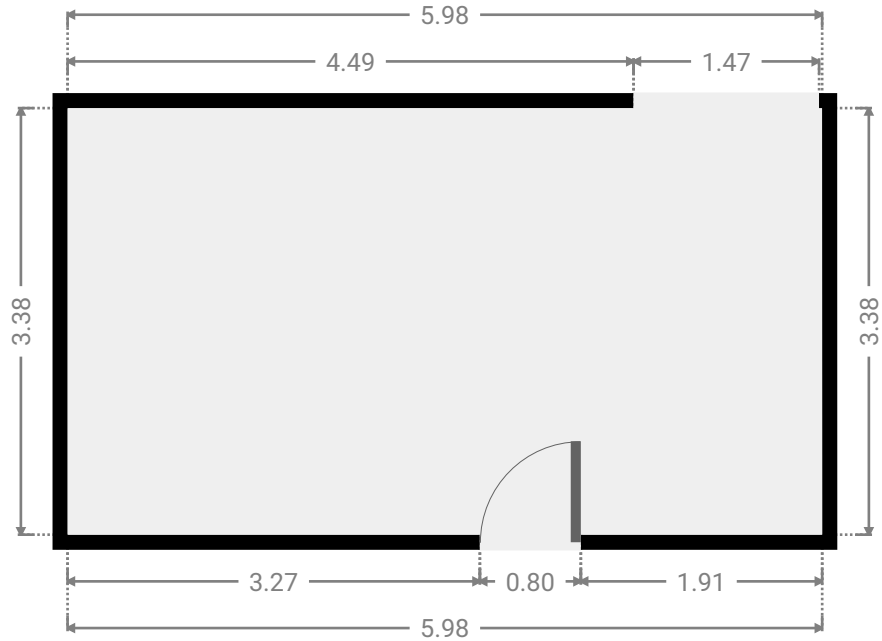
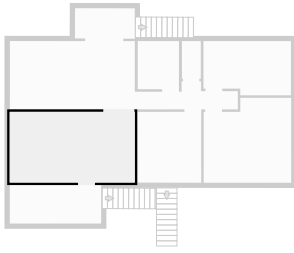

▼ Kitchen
1st Floor

WIDTH: 5.97 m • LENGTH: 3.26 m
AREA: 19.47 m² • PERIMETER: 18.46 m

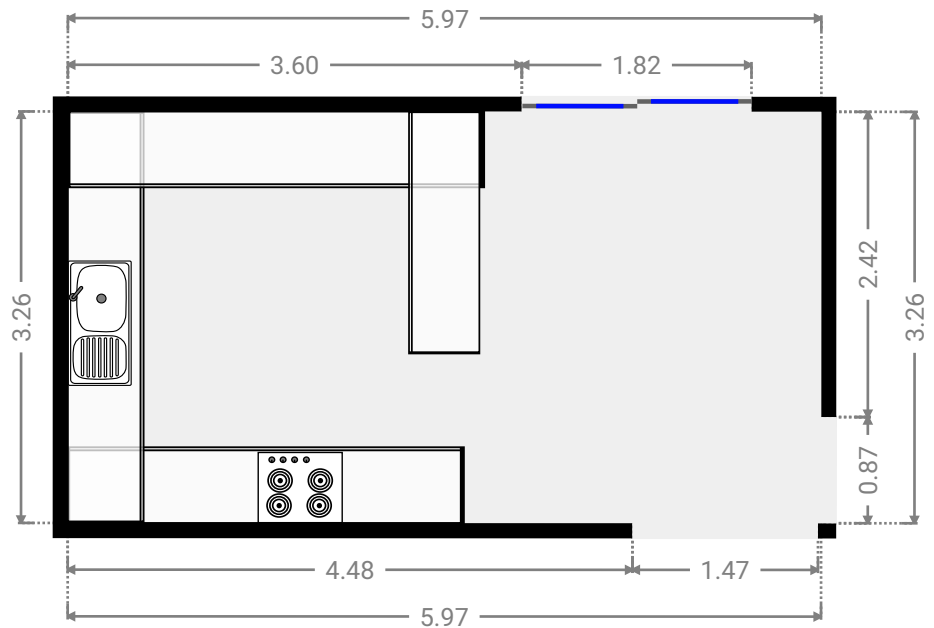
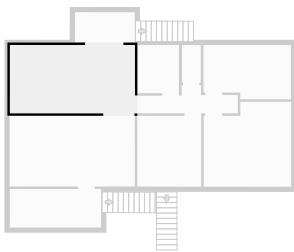

▼ **Hall**
1st Floor

WIDTH: 4.80 m • LENGTH: 1.34 m
AREA: 4.55 m² • PERIMETER: 12.28 m

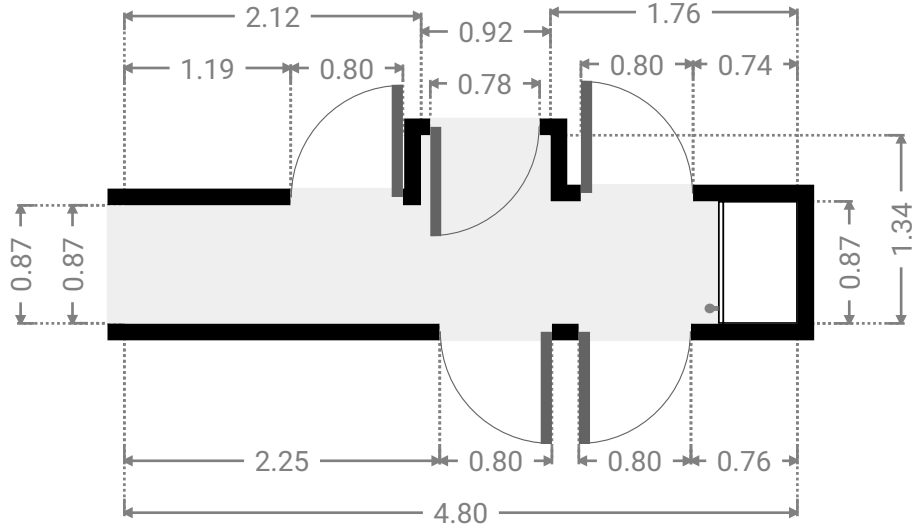
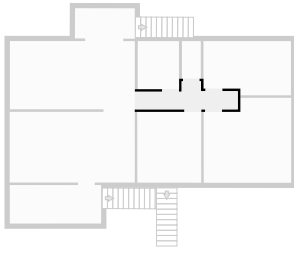

▼ **Bathroom**
1st Floor

WIDTH: 1.97 m • LENGTH: 2.30 m
AREA: 4.53 m² • PERIMETER: 8.54 m

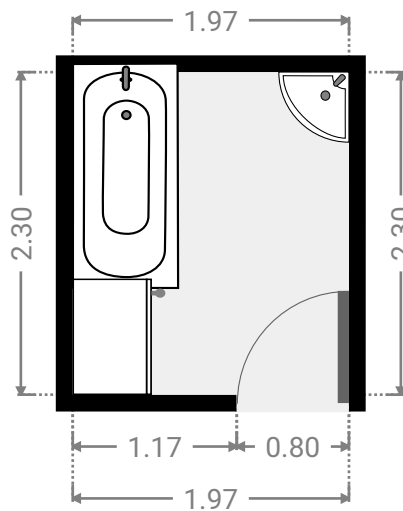
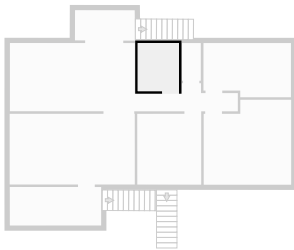

▼ **Toilet**
1st Floor

WIDTH: 0.90 m • LENGTH: 1.80 m
AREA: 1.62 m² • PERIMETER: 5.40 m

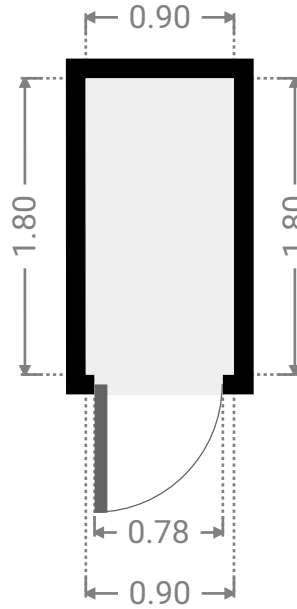
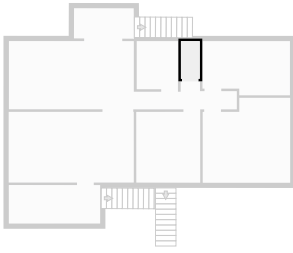

▼ **Bedroom**
1st Floor

WIDTH: 4.18 m • LENGTH: 2.59 m
AREA: 10.26 m² • PERIMETER: 13.54 m

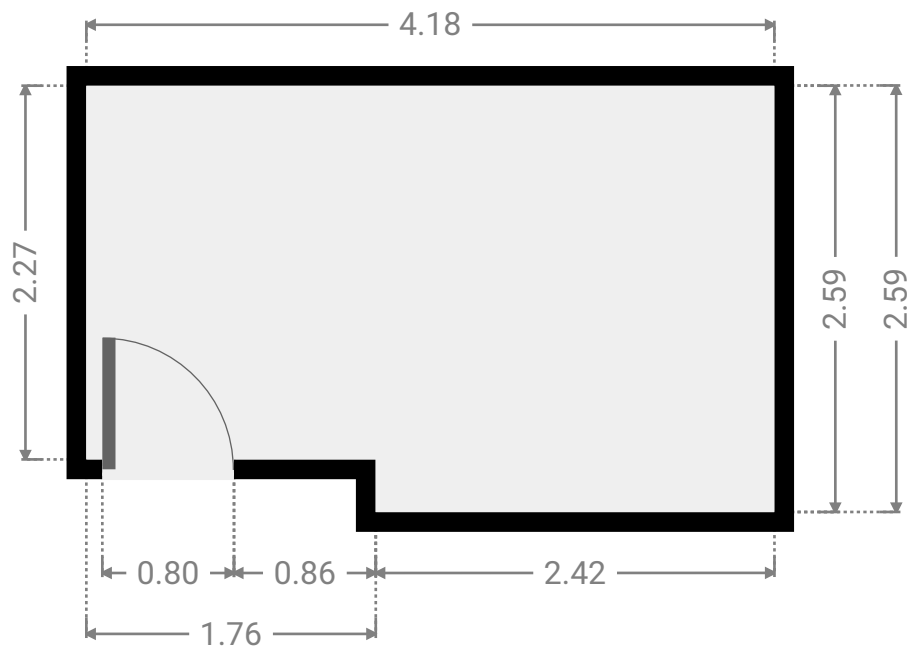
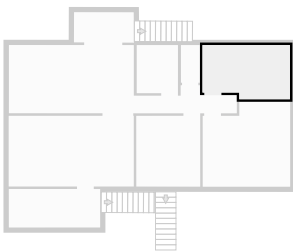

▼ **Bedroom**
1st Floor

WIDTH: 4.18 m • LENGTH: 4.06 m
AREA: 15.79 m² • PERIMETER: 16.48 m

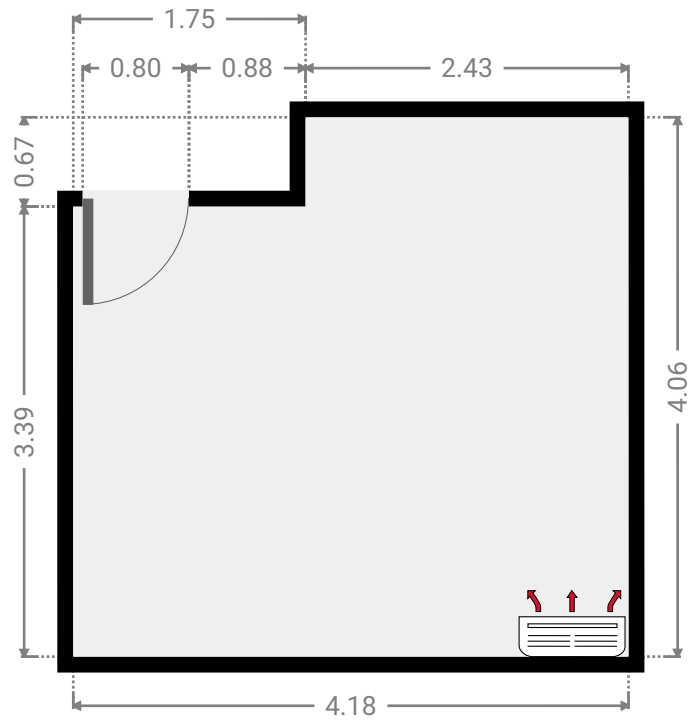
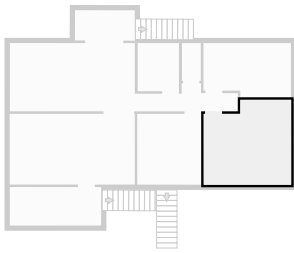

▼ **Bedroom**
1st Floor

WIDTH: 3.06 m • LENGTH: 3.39 m
AREA: 10.34 m² • PERIMETER: 12.88 m

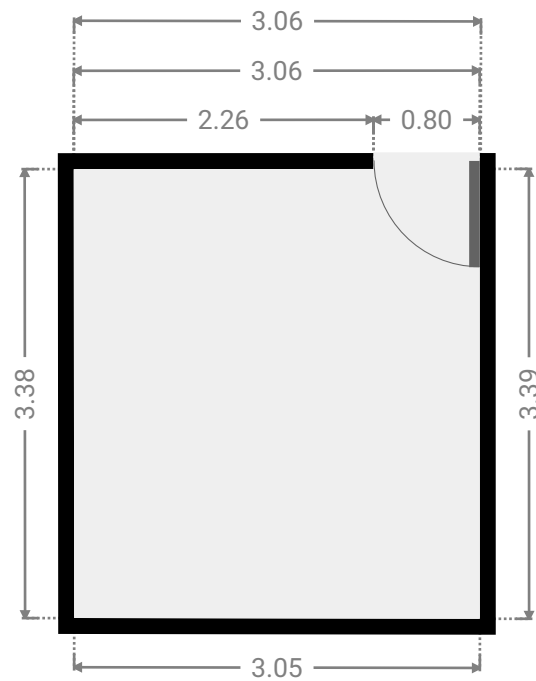
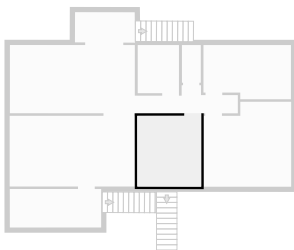

▼ Other
1st Floor

WIDTH: 2.88 m • LENGTH: 1.45 m
AREA: 4.14 m² • PERIMETER: 8.62 m

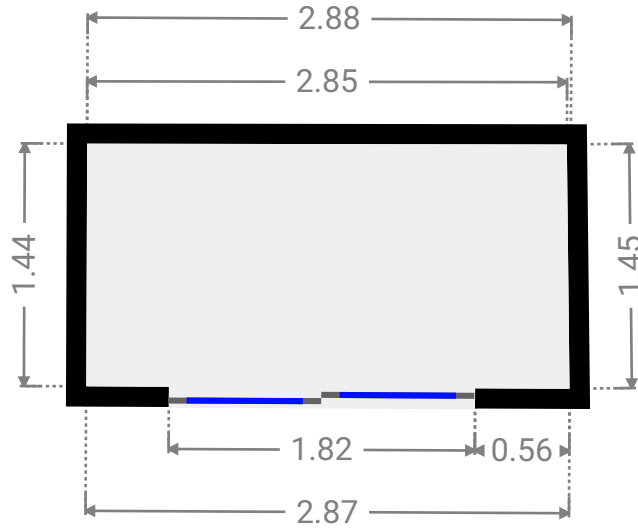
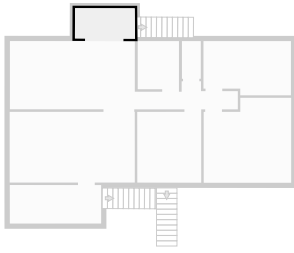

▼ Other
1st Floor

WIDTH: 4.37 m • LENGTH: 1.84 m
AREA: 8.03 m² • PERIMETER: 12.41 m

