

# 8 Owen Avenue

Created on  
2021-03-23

Floors  
1

▼ Ground Floor



▼ **Hall**  
Ground Floor

WIDTH: 2.20 m • LENGTH: 10.45 m  
AREA: 15.42 m<sup>2</sup> • PERIMETER: 25.30 m

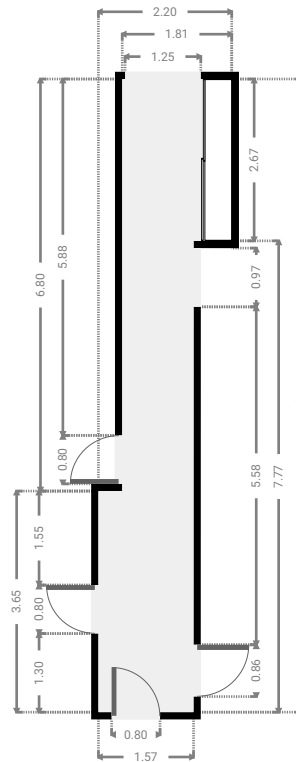
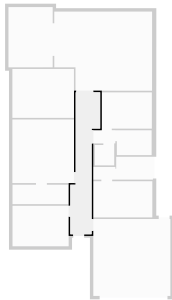

▼ **Bedroom**  
Ground Floor

WIDTH: 4.13 m • LENGTH: 2.98 m  
AREA: 12.31 m<sup>2</sup> • PERIMETER: 14.22 m

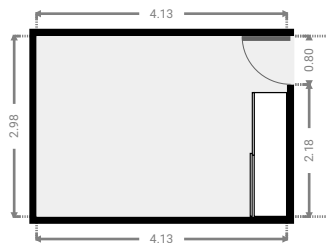
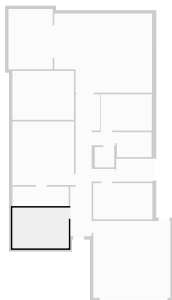

▼ **Garage**  
Ground Floor

WIDTH: 5.67 m • LENGTH: 5.66 m  
AREA: 32.09 m<sup>2</sup> • PERIMETER: 22.66 m

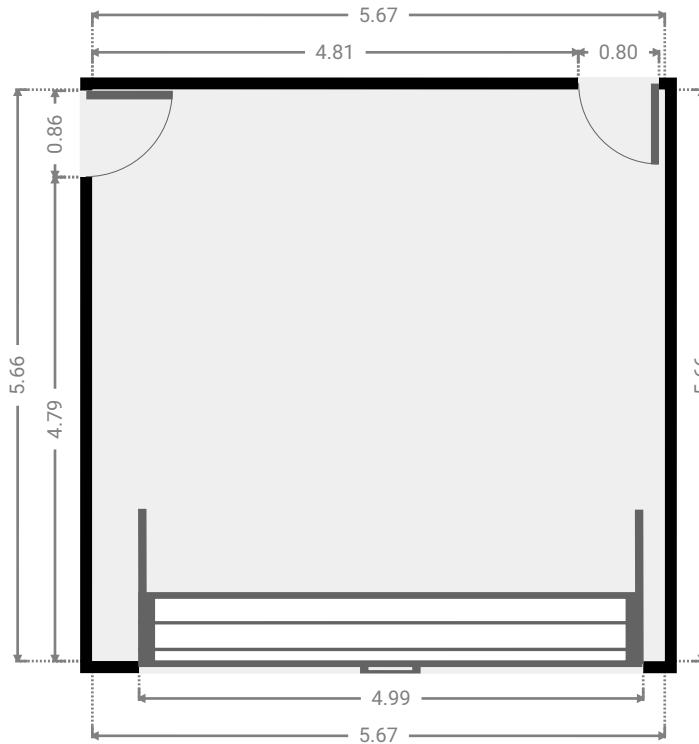

▼ **Bathroom**  
Ground Floor

WIDTH: 4.13 m • LENGTH: 1.43 m  
AREA: 5.91 m<sup>2</sup> • PERIMETER: 11.12 m

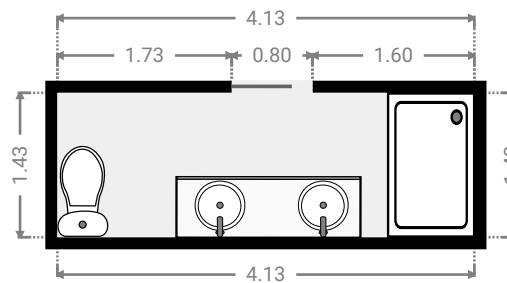
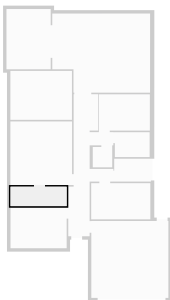

▼ **Master Bedroom**  
Ground Floor

WIDTH: 4.54 m • LENGTH: 4.68 m  
AREA: 21.25 m<sup>2</sup> • PERIMETER: 18.44 m

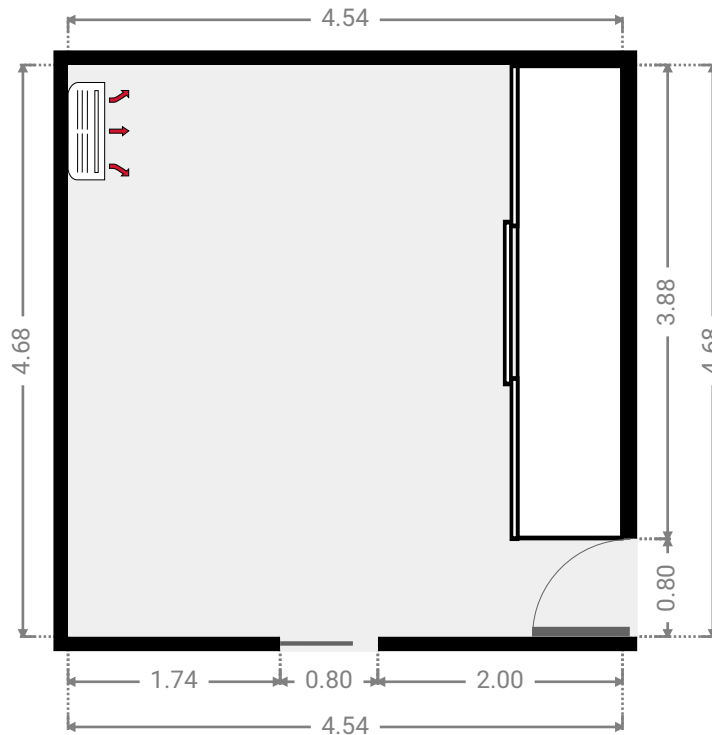
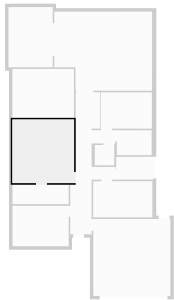

▼ **Bedroom**  
Ground Floor

WIDTH: 4.35 m • LENGTH: 2.66 m  
AREA: 11.57 m<sup>2</sup> • PERIMETER: 14.02 m

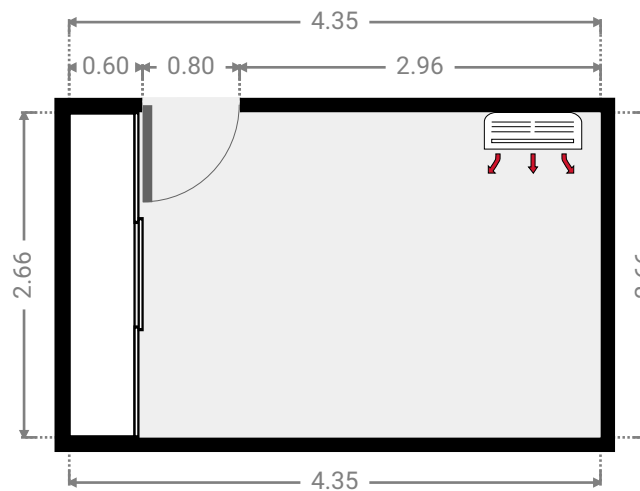
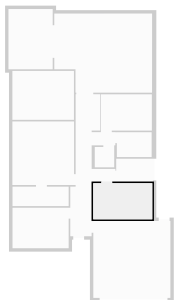

▼ Hall  
Ground Floor

WIDTH: 1.68 m • LENGTH: 0.93 m  
AREA: 1.56 m<sup>2</sup> • PERIMETER: 5.22 m

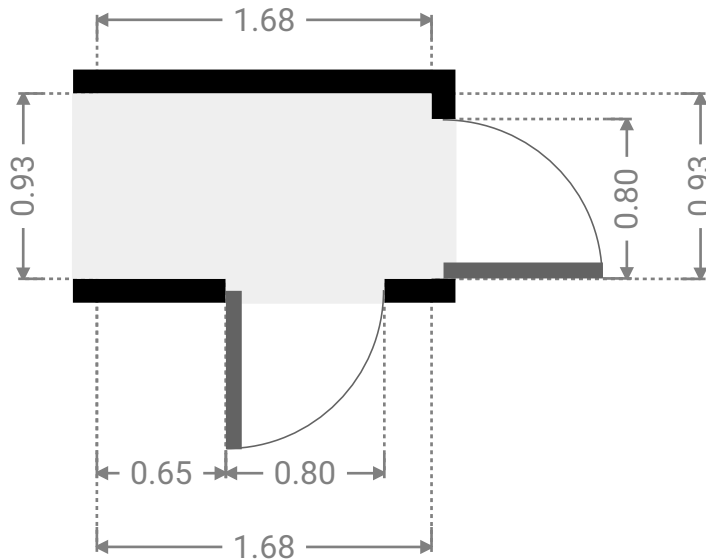

▼ Laundry Room  
Ground Floor

WIDTH: 2.70 m • LENGTH: 1.68 m  
AREA: 4.53 m<sup>2</sup> • PERIMETER: 8.76 m

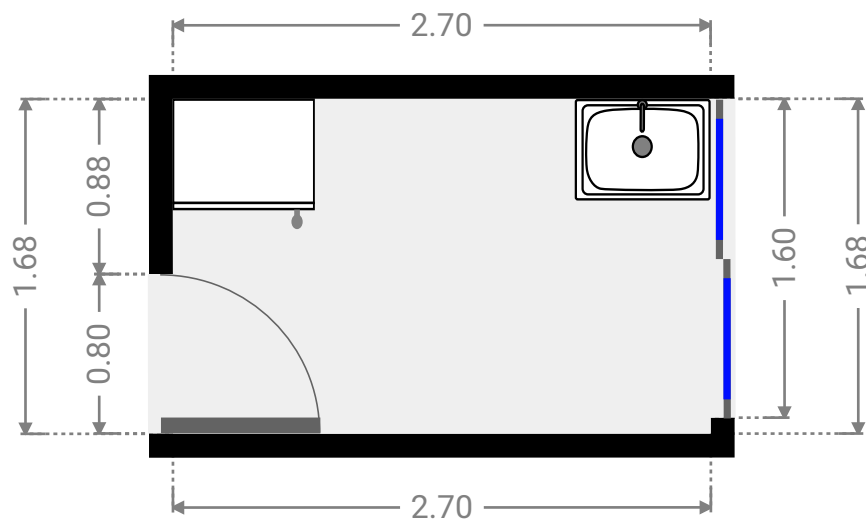

▼ Toilet  
Ground Floor

WIDTH: 1.43 m • LENGTH: 1.50 m  
AREA: 2.15 m<sup>2</sup> • PERIMETER: 5.86 m

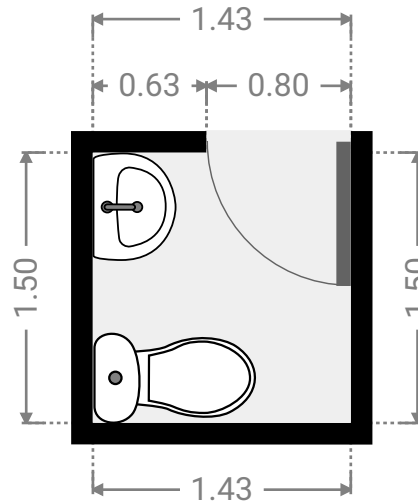
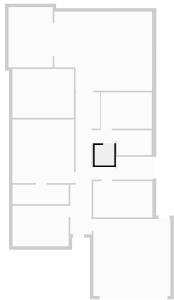

▼ Hall  
Ground Floor

WIDTH: 1.62 m • LENGTH: 0.97 m  
AREA: 1.57 m<sup>2</sup> • PERIMETER: 5.18 m

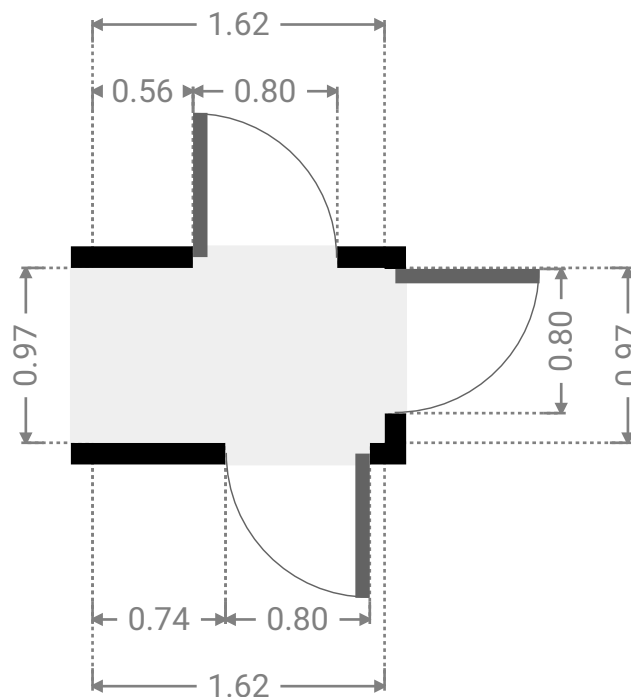

▼ **Bedroom**  
Ground Floor

WIDTH: 3.75 m • LENGTH: 2.67 m  
AREA: 10.01 m<sup>2</sup> • PERIMETER: 12.84 m

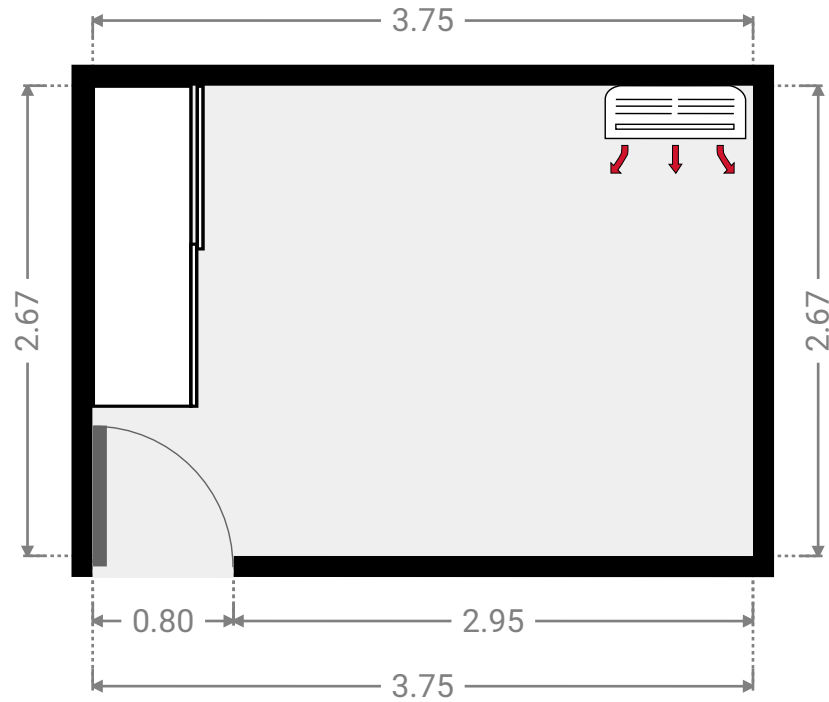
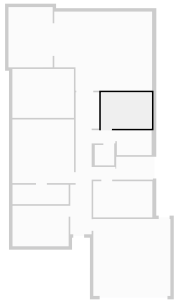

▼ **Bathroom**  
Ground Floor

WIDTH: 2.56 m • LENGTH: 1.83 m  
AREA: 4.69 m<sup>2</sup> • PERIMETER: 8.78 m

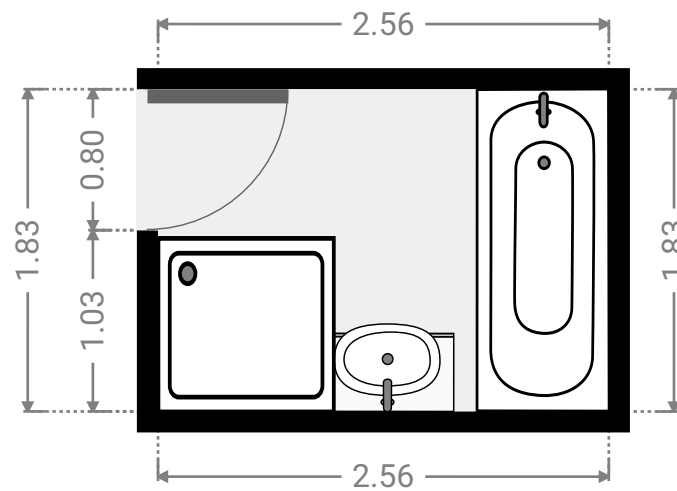



▼ Living Room  
Ground Floor

WIDTH: 4.53 m • LENGTH: 3.60 m  
AREA: 16.31 m<sup>2</sup> • PERIMETER: 16.26 m

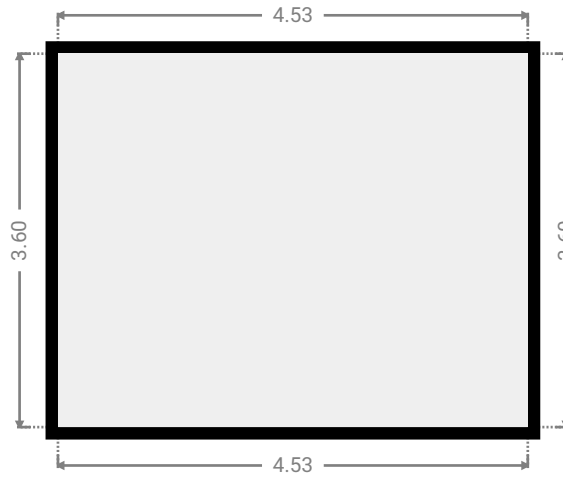
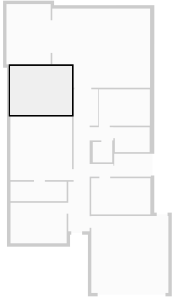

▼ Kitchen/Dining/Living  
Ground Floor

WIDTH: 7.20 m • LENGTH: 5.82 m  
AREA: 39.21 m<sup>2</sup> • PERIMETER: 26.04 m

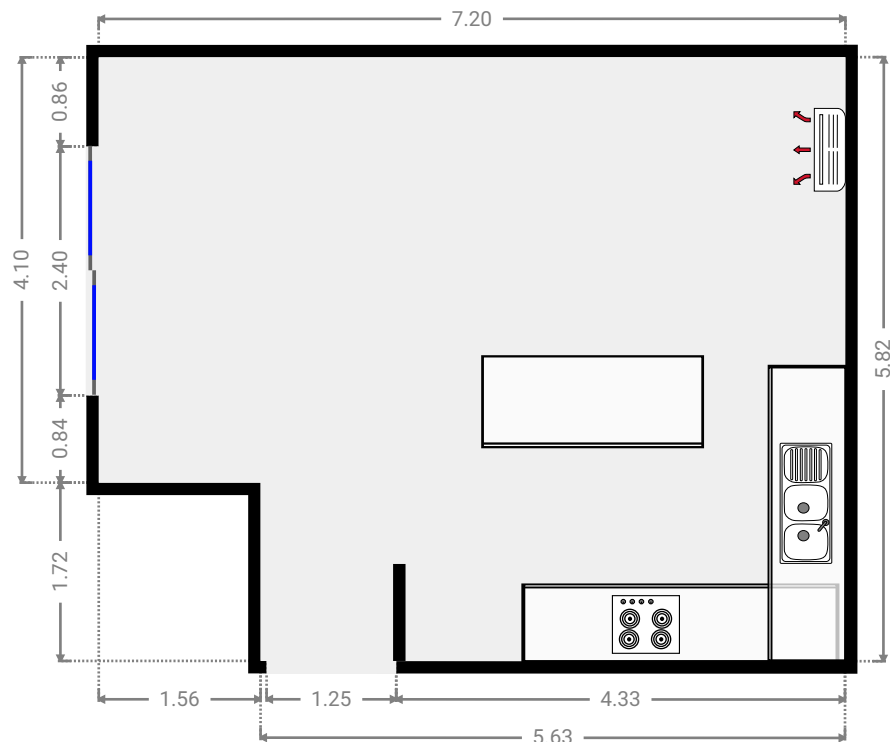

▼ **Patio**  
Ground Floor

WIDTH: 3.25 m • LENGTH: 4.43 m  
AREA: 14.42 m<sup>2</sup> • PERIMETER: 15.37 m

