

78 Corella Drive

SUBMITTED BY
Janelle Casey
stockers@cqoz.com

CREATED ON
2021-10-28

Floors 1

▼ Ground Floor

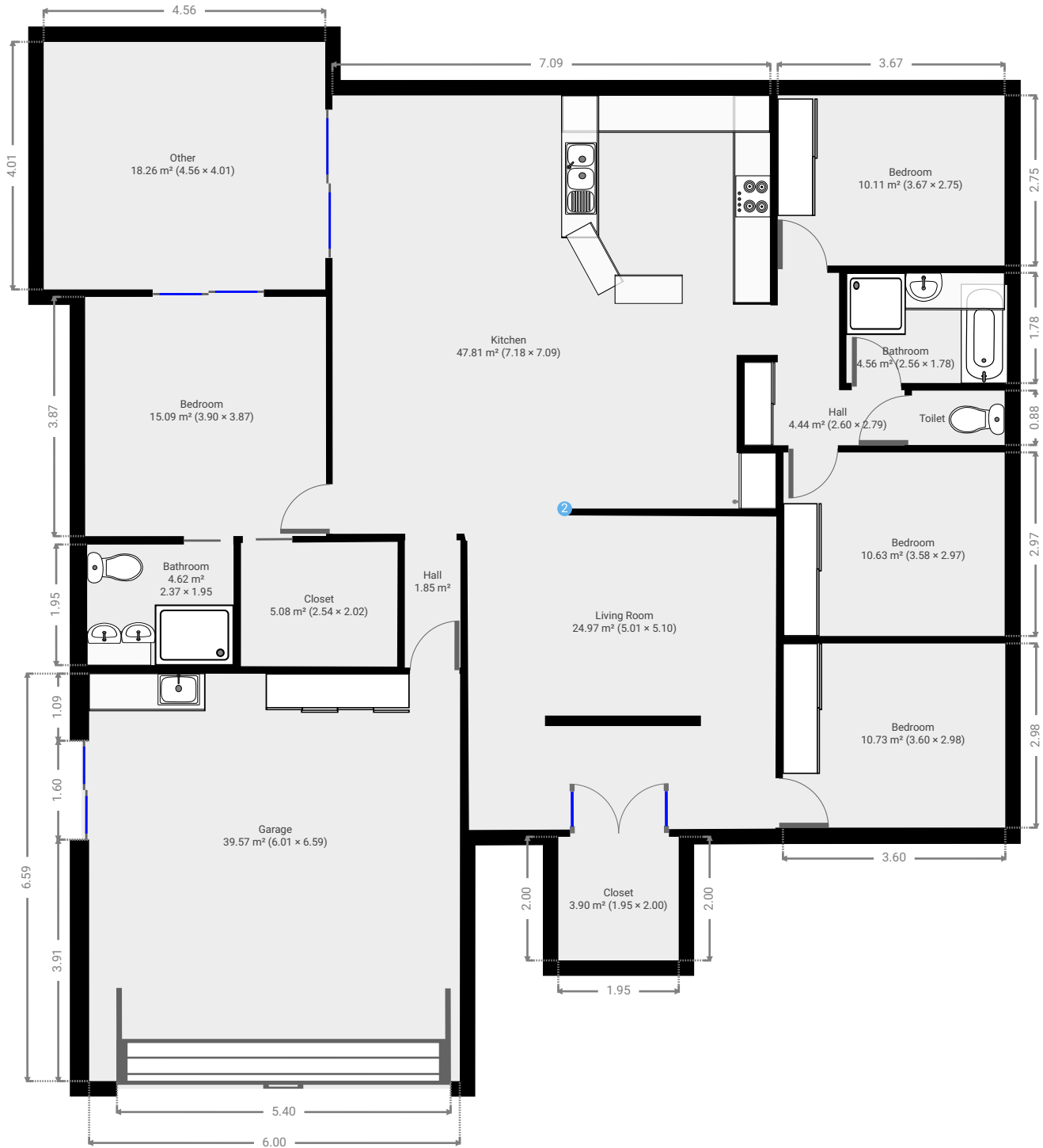

▼ Living Room
Ground Floor

WIDTH: 5.01 m • LENGTH: 5.10 m
AREA: 24.97 m² • PERIMETER: 19.76 m

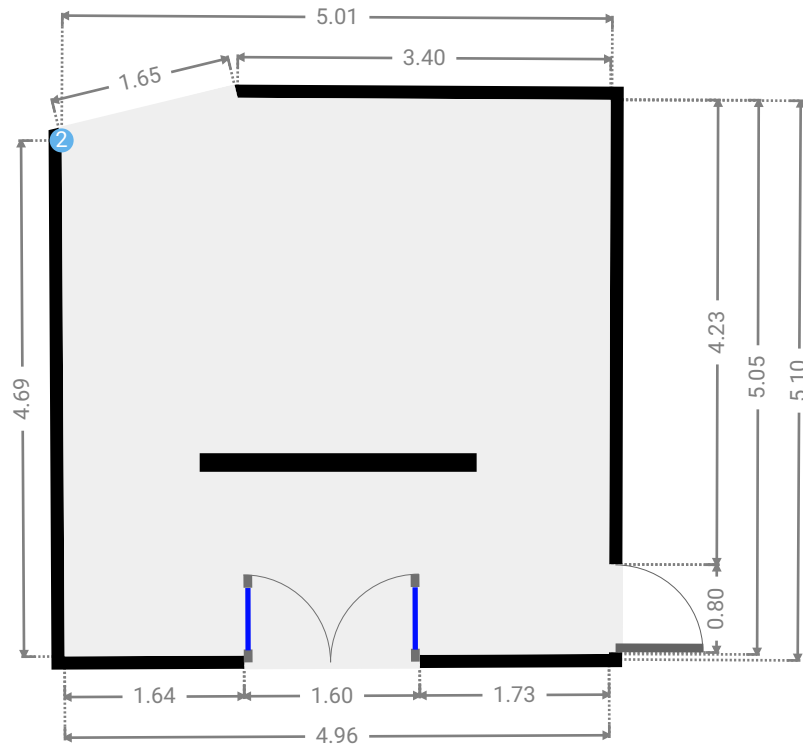
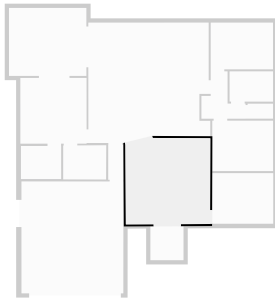

▼ Bedroom
Ground Floor

WIDTH: 3.60 m • LENGTH: 2.98 m
AREA: 10.73 m² • PERIMETER: 13.16 m

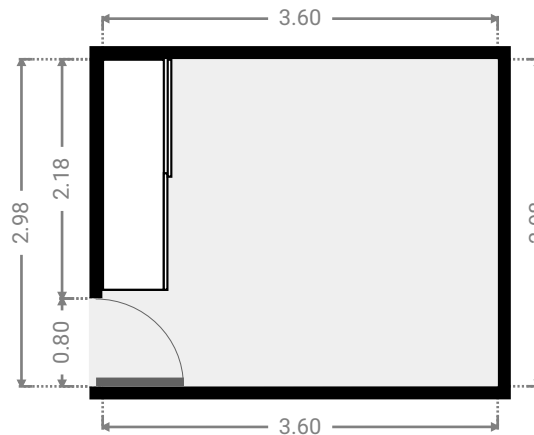
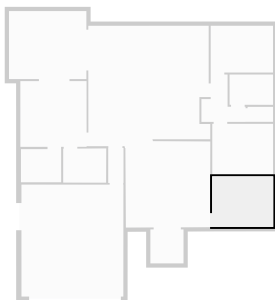

▼ Kitchen
Ground Floor

WIDTH: 7.18 m • LENGTH: 7.09 m
AREA: 47.81 m² • PERIMETER: 29.29 m

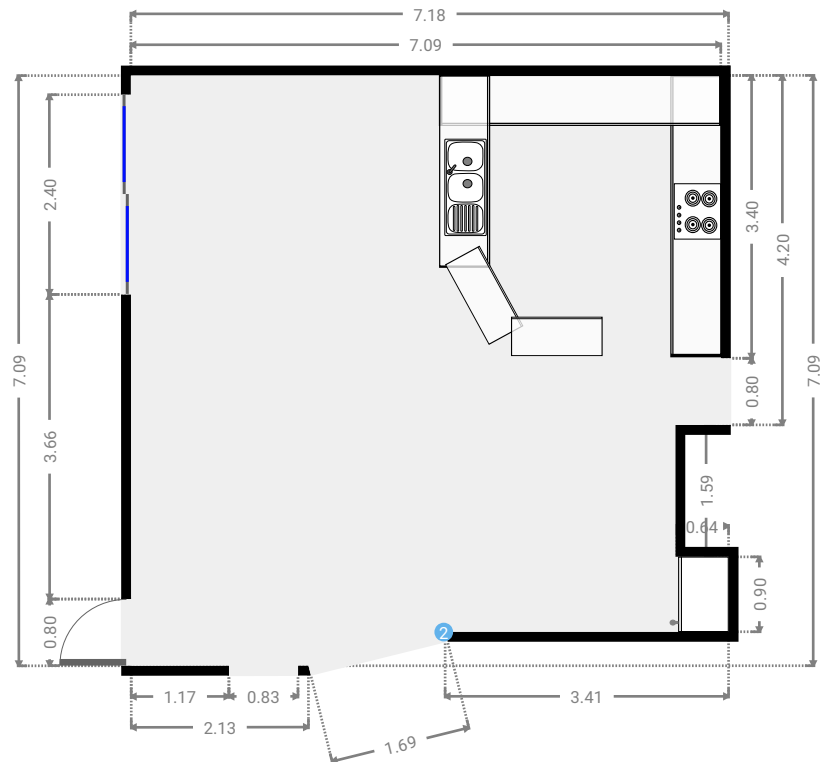
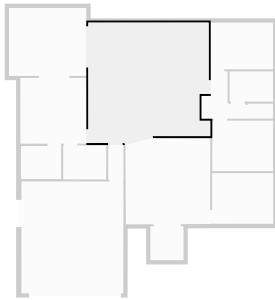

▼ Kitchen/Ground Floor

2 OPENING

Height
0.00 m



▼ **Hall**
Ground Floor

WIDTH: 0.90 m • LENGTH: 2.06 m
AREA: 1.85 m² • PERIMETER: 5.92 m

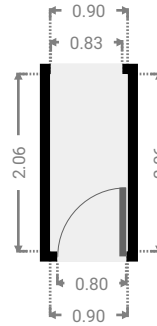
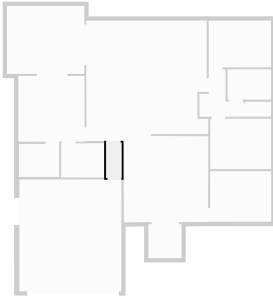

▼ **Garage**
Ground Floor

WIDTH: 6.01 m • LENGTH: 6.59 m
AREA: 39.57 m² • PERIMETER: 25.19 m

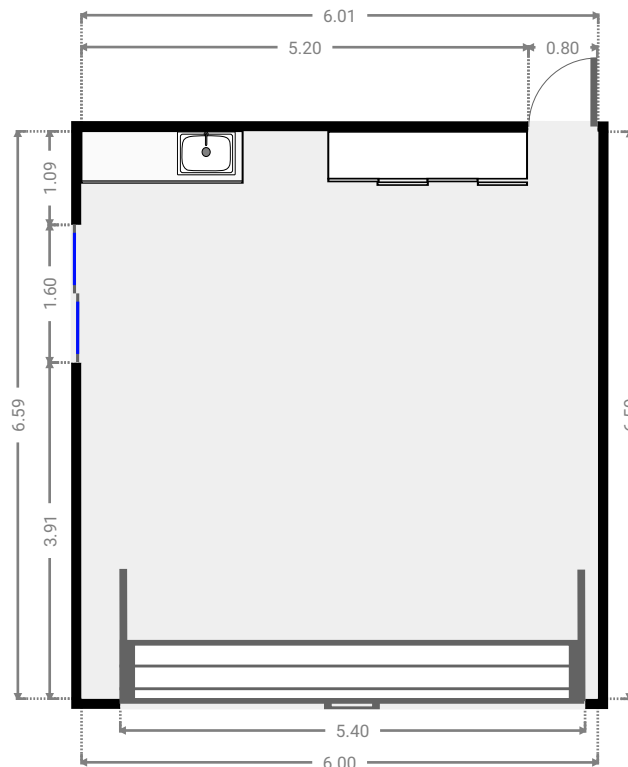
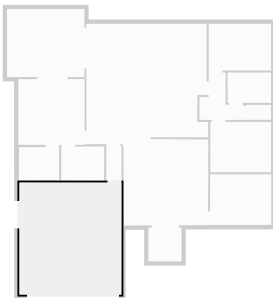

▼ **Bedroom**
Ground Floor

WIDTH: 3.90 m • LENGTH: 3.87 m
AREA: 15.09 m² • PERIMETER: 15.54 m

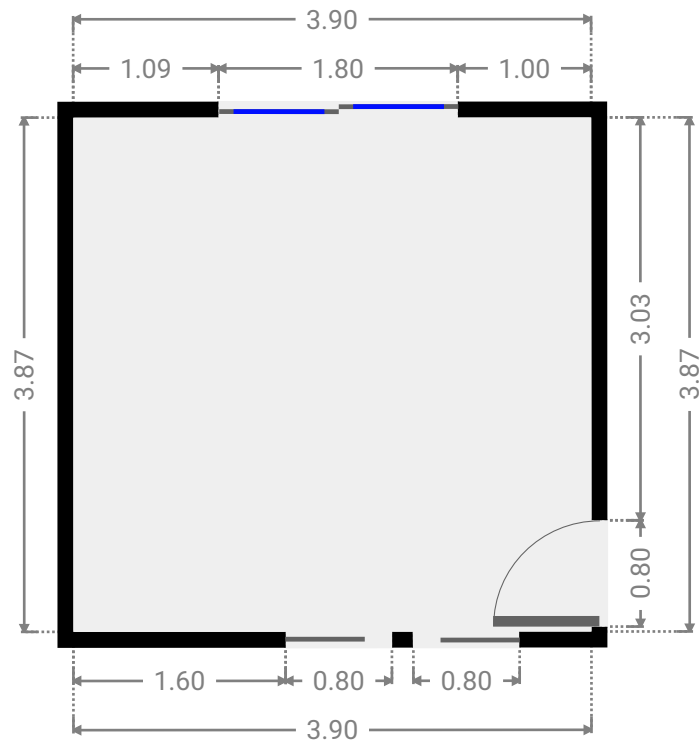
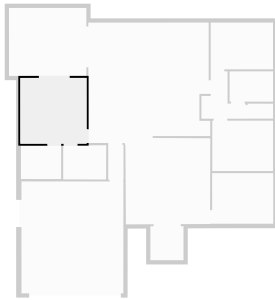

▼ **Bathroom**
Ground Floor

WIDTH: 2.37 m • LENGTH: 1.95 m
AREA: 4.62 m² • PERIMETER: 8.64 m

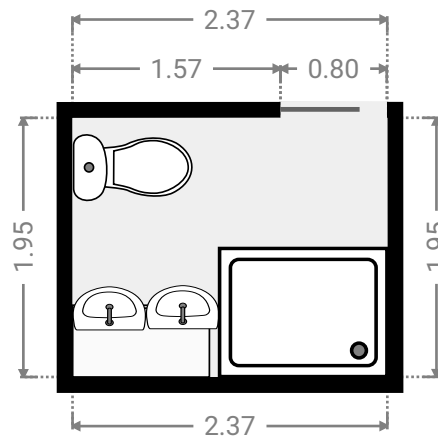
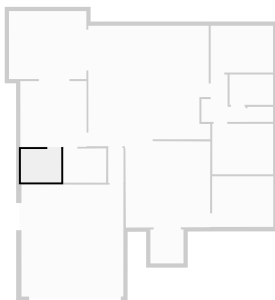

▼ **Closet**
Ground Floor

WIDTH: 2.54 m • LENGTH: 2.02 m
AREA: 5.08 m² • PERIMETER: 9.08 m

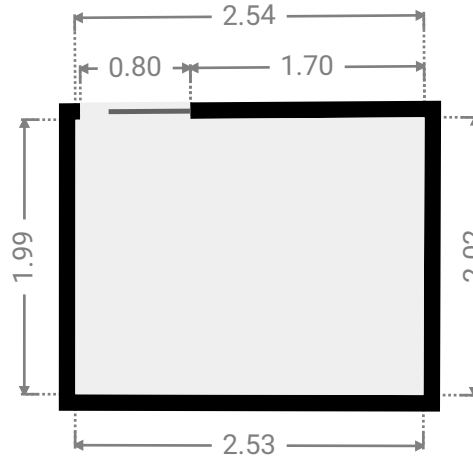
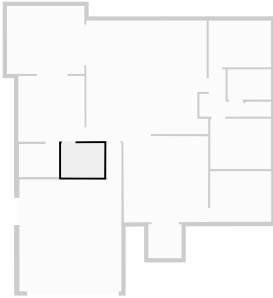

▼ **Other**
Ground Floor

WIDTH: 4.56 m • LENGTH: 4.01 m
AREA: 18.26 m² • PERIMETER: 17.13 m

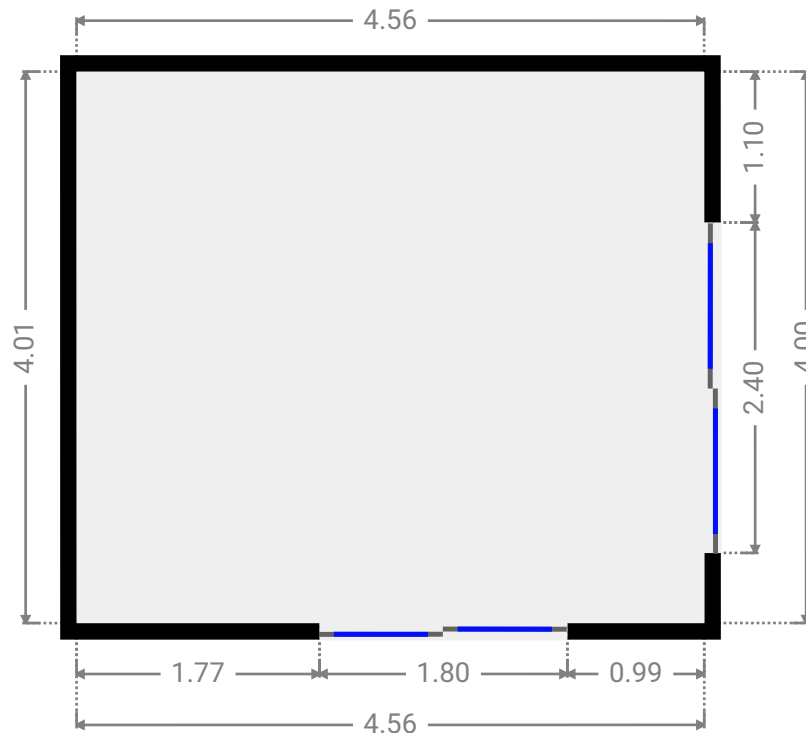
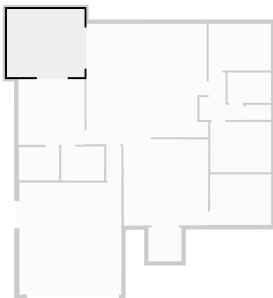

▼ **Hall**
Ground Floor

WIDTH: 2.60 m • LENGTH: 2.79 m
AREA: 4.44 m² • PERIMETER: 10.78 m

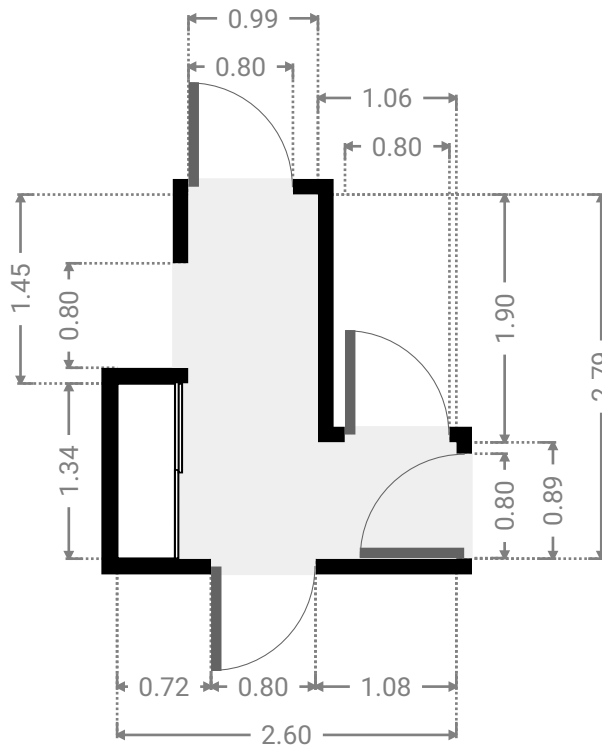
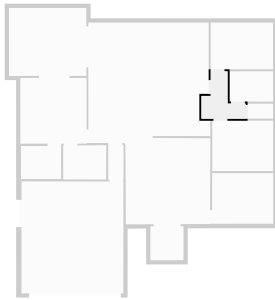

▼ **Bedroom**
Ground Floor

WIDTH: 3.58 m • LENGTH: 2.97 m
AREA: 10.63 m² • PERIMETER: 13.10 m

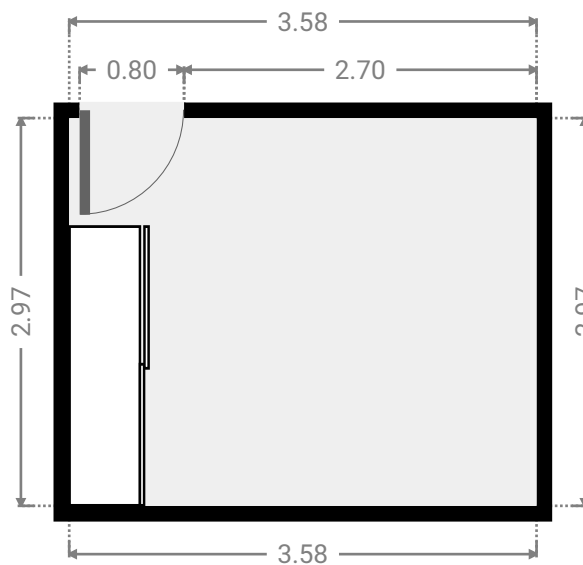
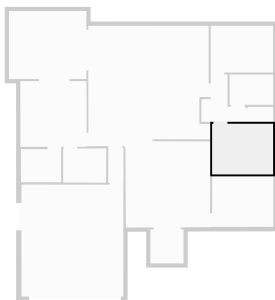

▼ **Toilet**
Ground Floor

WIDTH: 1.50 m • LENGTH: 0.88 m
AREA: 1.32 m² • PERIMETER: 4.76 m

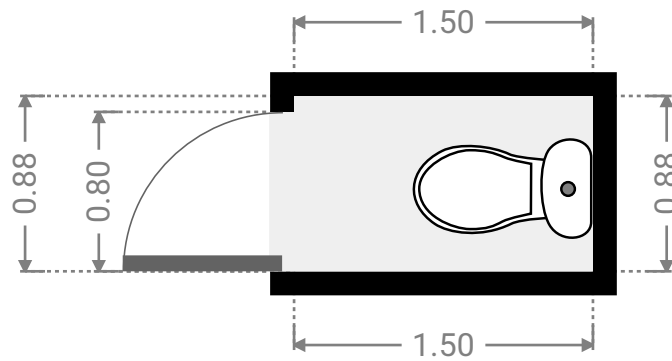
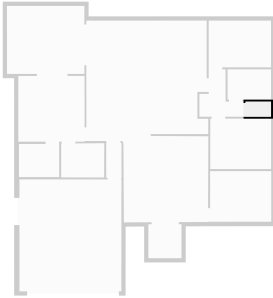

▼ **Bathroom**
Ground Floor

WIDTH: 2.56 m • LENGTH: 1.78 m
AREA: 4.56 m² • PERIMETER: 8.68 m

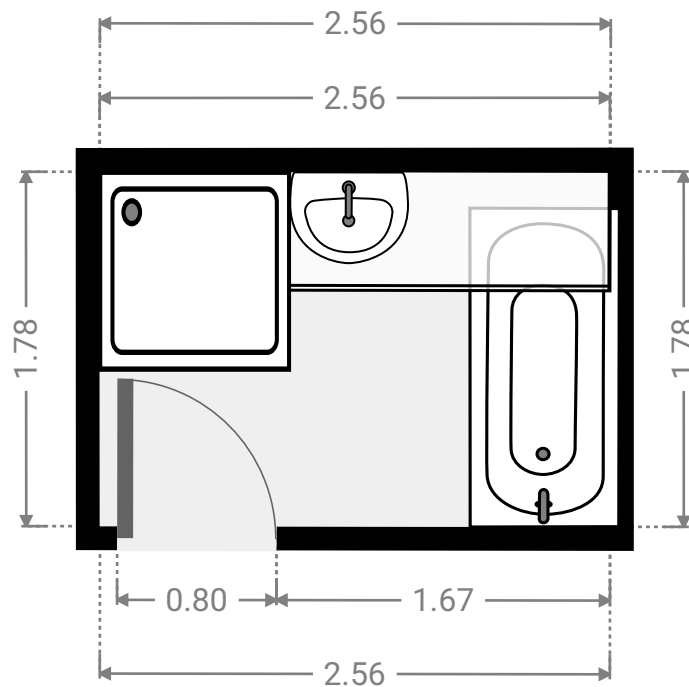
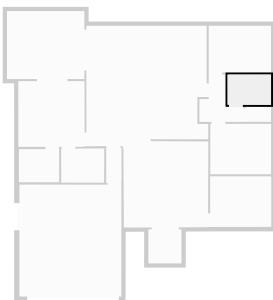

▼ **Bedroom**
Ground Floor

WIDTH: 3.67 m • LENGTH: 2.75 m
AREA: 10.11 m² • PERIMETER: 12.85 m

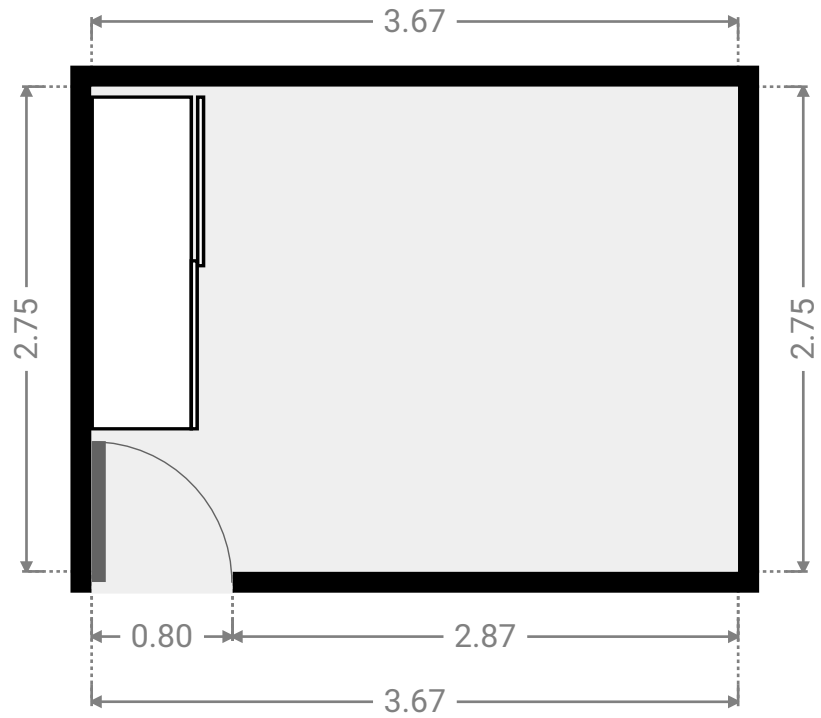
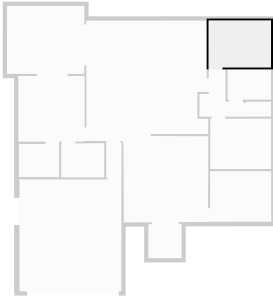

▼ **Closet**
Ground Floor

WIDTH: 1.95 m • LENGTH: 2.00 m
AREA: 3.90 m² • PERIMETER: 7.90 m

