

76 Cherryfield Road

Created on
2021-07-05

Floors
1

▼ Ground Floor

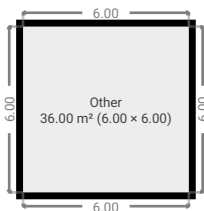
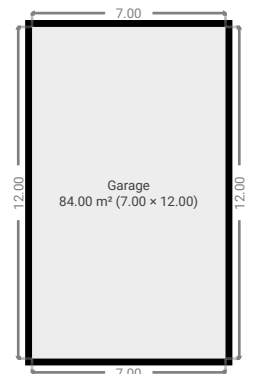
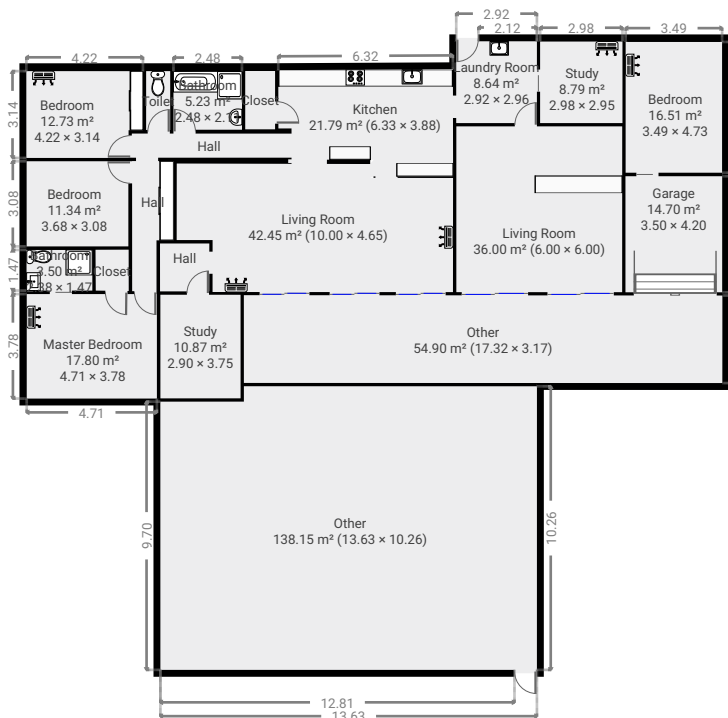
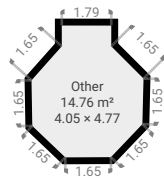
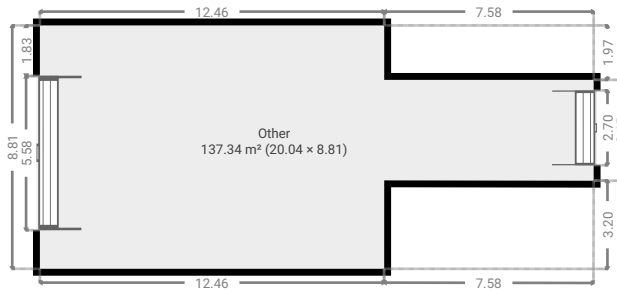

▼ **Hall**
Ground Floor

WIDTH: 1.78 m • LENGTH: 1.73 m
AREA: 3.09 m² • PERIMETER: 7.03 m

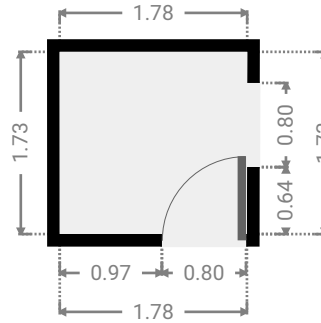
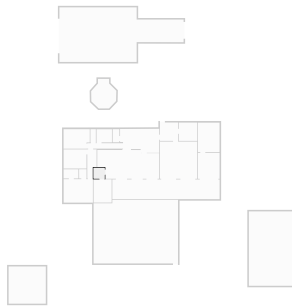

▼ **Other**
Ground Floor

WIDTH: 6.00 m • LENGTH: 6.00 m
AREA: 36.00 m² • PERIMETER: 24.00 m

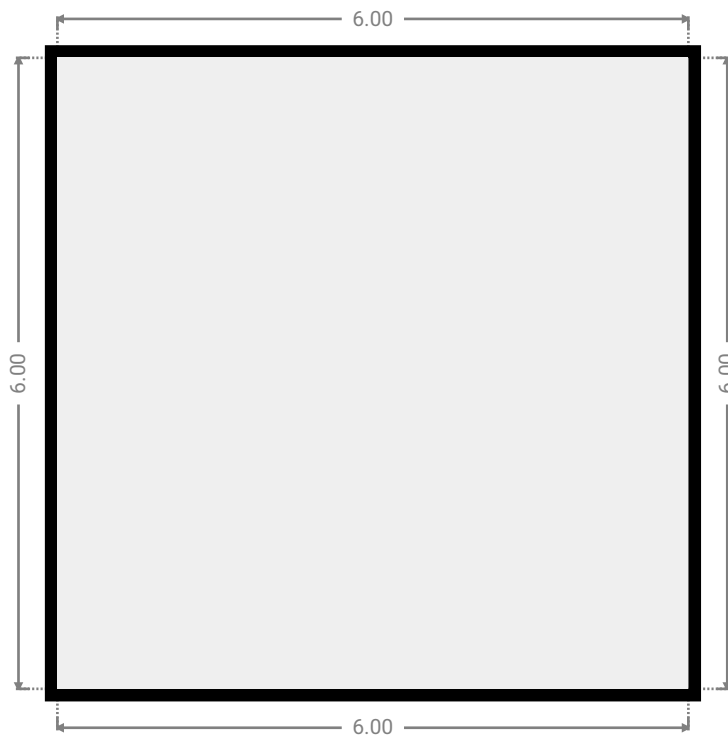
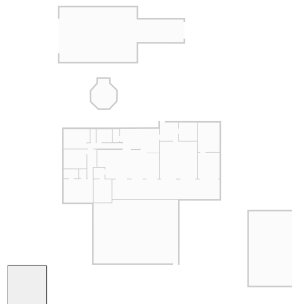

▼ **Garage**
Ground Floor

WIDTH: 7.00 m • LENGTH: 12.00 m
AREA: 84.00 m² • PERIMETER: 38.00 m

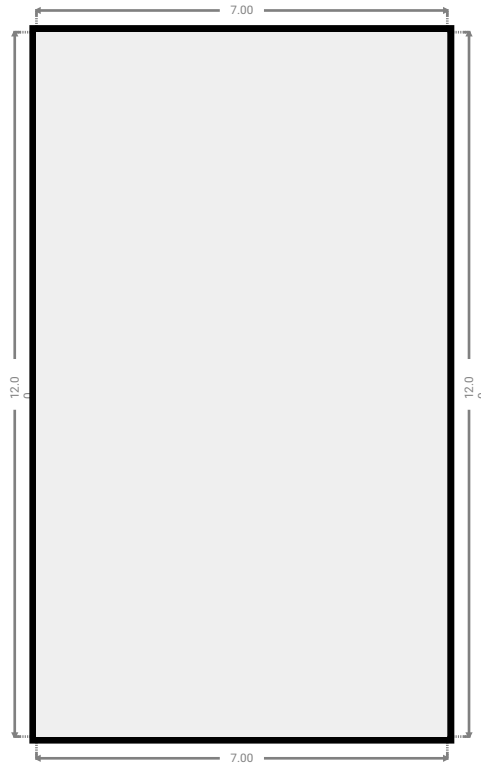
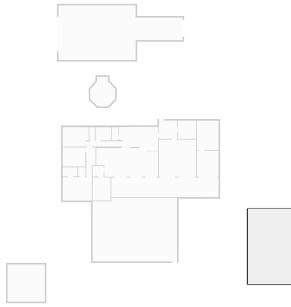

▼ **Other**
Ground Floor

WIDTH: 13.63 m • LENGTH: 10.26 m
AREA: 138.15 m² • PERIMETER: 47.78 m

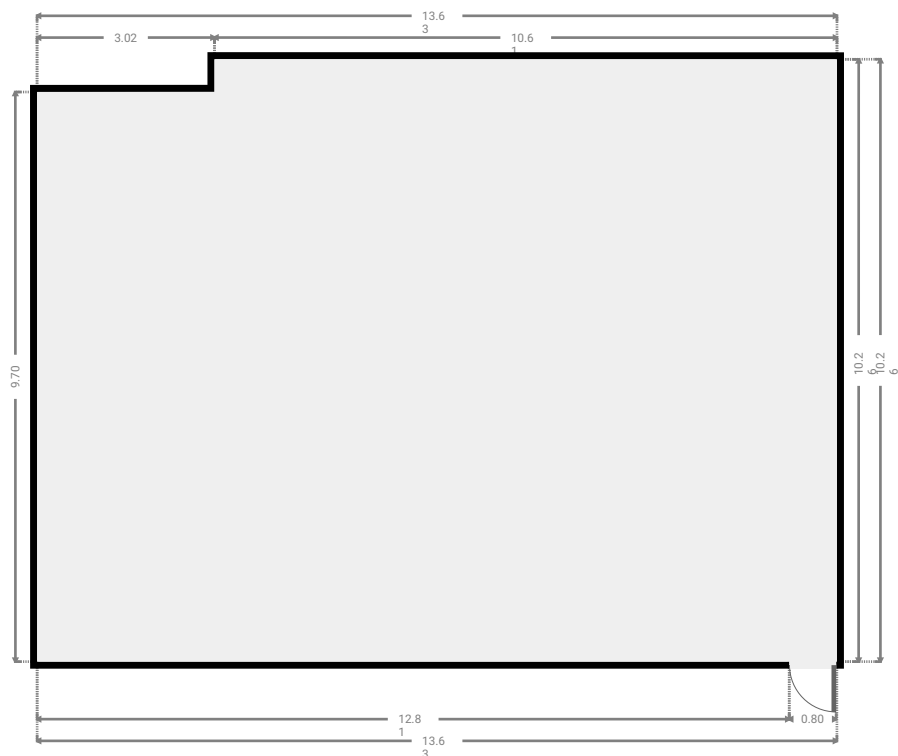
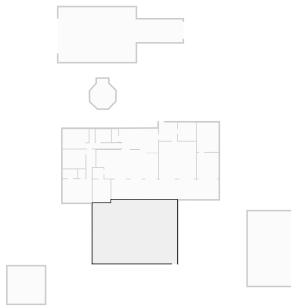

▼ Other Ground Floor

WIDTH: 20.04 m • LENGTH: 8.81 m
AREA: 137.34 m² • PERIMETER: 57.70 m

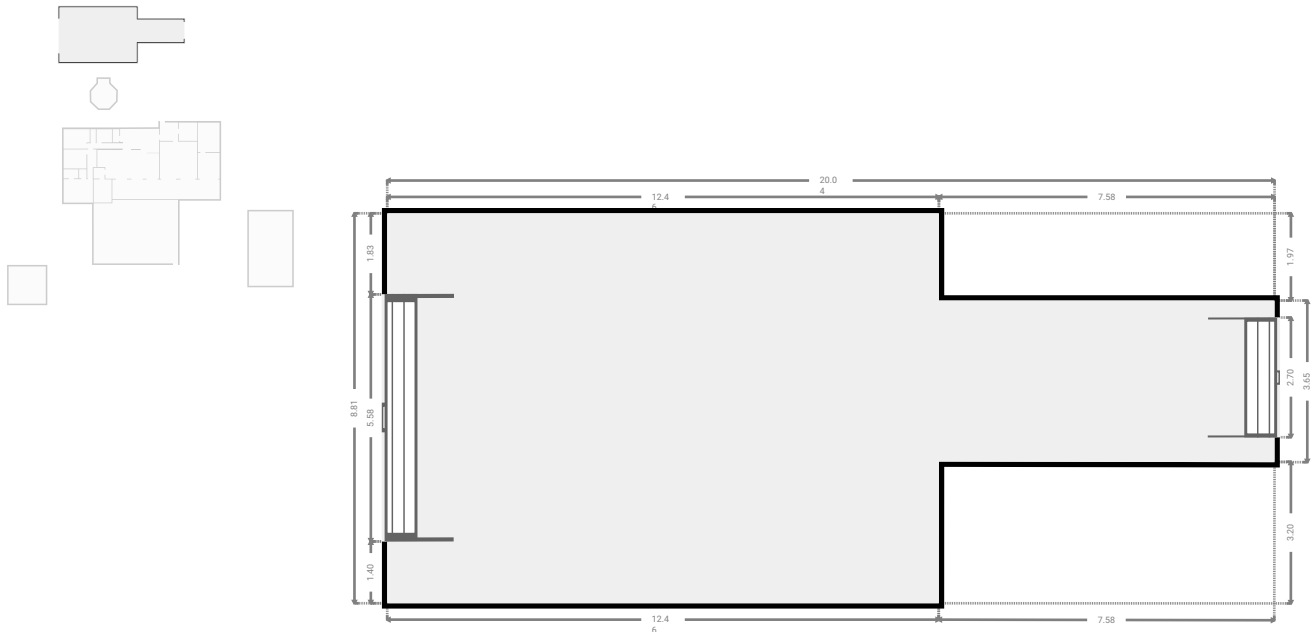

▼ Other Ground Floor

WIDTH: 4.05 m • LENGTH: 4.77 m
AREA: 14.76 m² • PERIMETER: 14.84 m

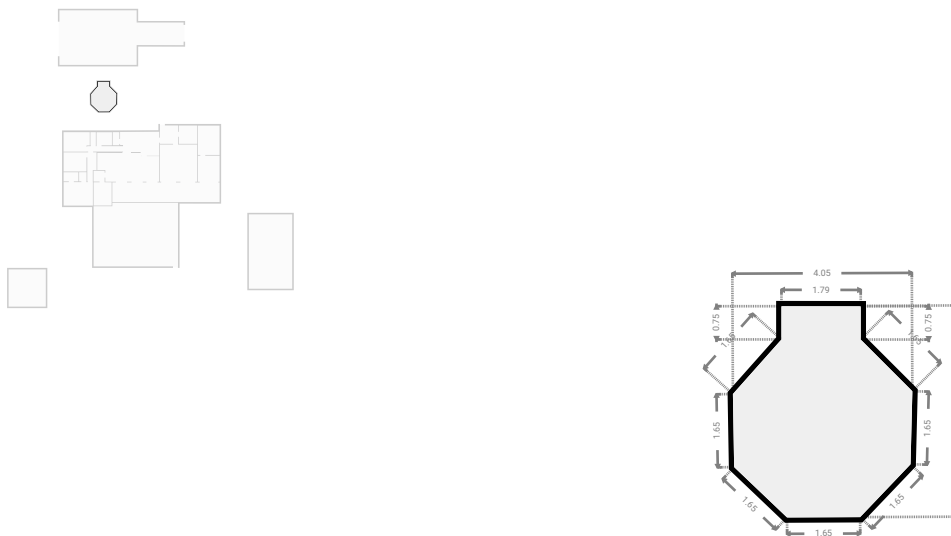

▼ Other Ground Floor

WIDTH: 17.32 m • LENGTH: 3.17 m
AREA: 54.90 m² • PERIMETER: 40.97 m

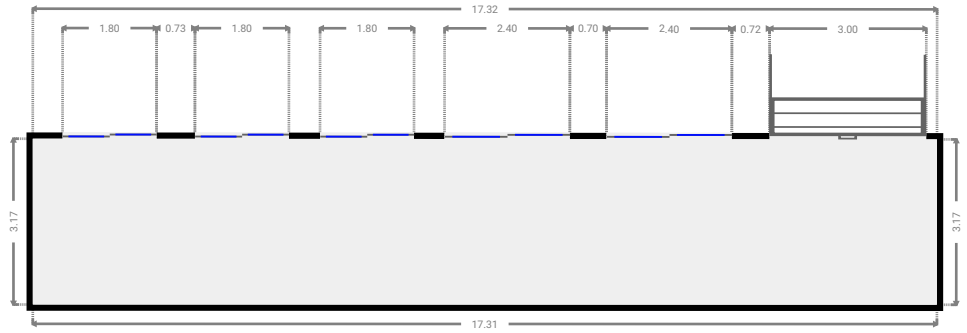
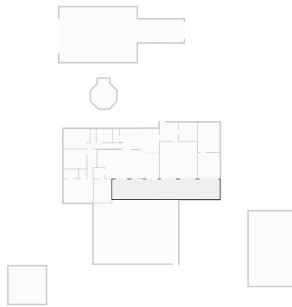

▼ Bedroom Ground Floor

WIDTH: 3.49 m • LENGTH: 4.73 m
AREA: 16.51 m² • PERIMETER: 16.44 m

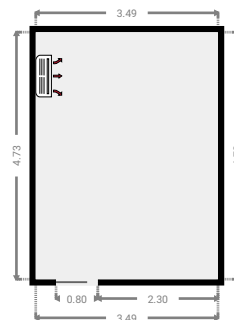
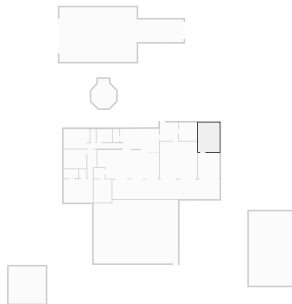

▼ **Garage**
Ground Floor

WIDTH: 3.50 m • LENGTH: 4.20 m
AREA: 14.70 m² • PERIMETER: 15.40 m

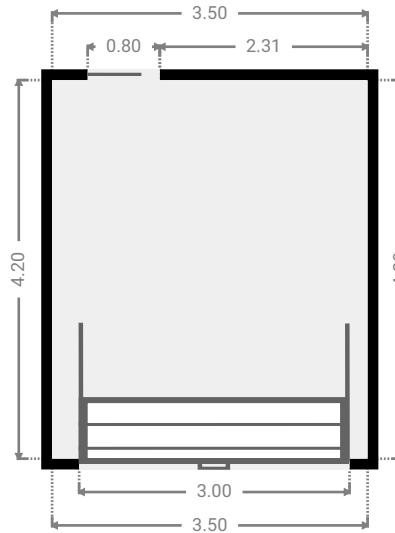
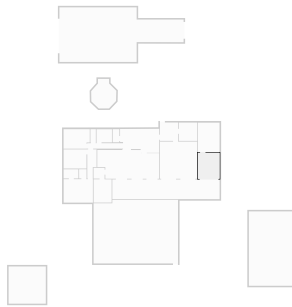

▼ **Living Room**
Ground Floor

WIDTH: 6.00 m • LENGTH: 6.00 m
AREA: 36.00 m² • PERIMETER: 24.00 m

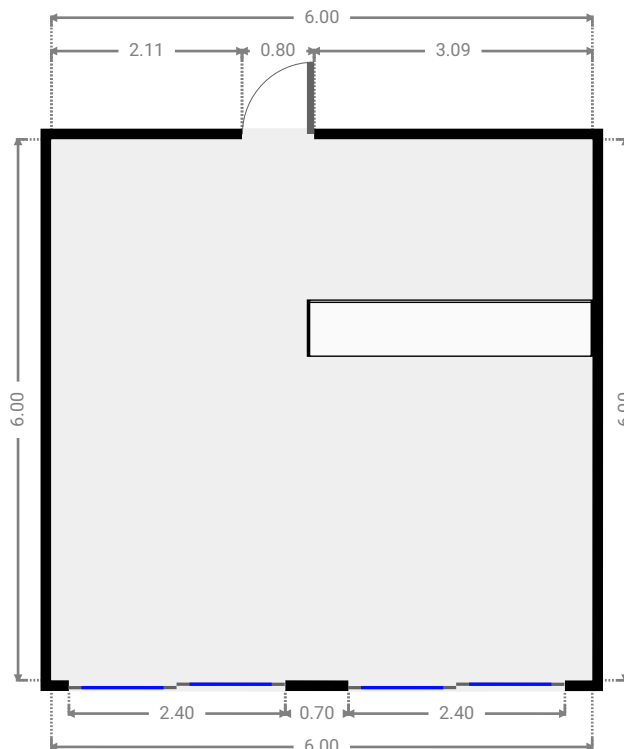
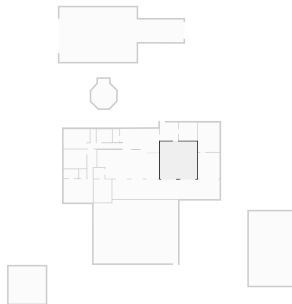

▼ Study
Ground Floor

WIDTH: 2.98 m • LENGTH: 2.95 m
AREA: 8.79 m² • PERIMETER: 11.86 m

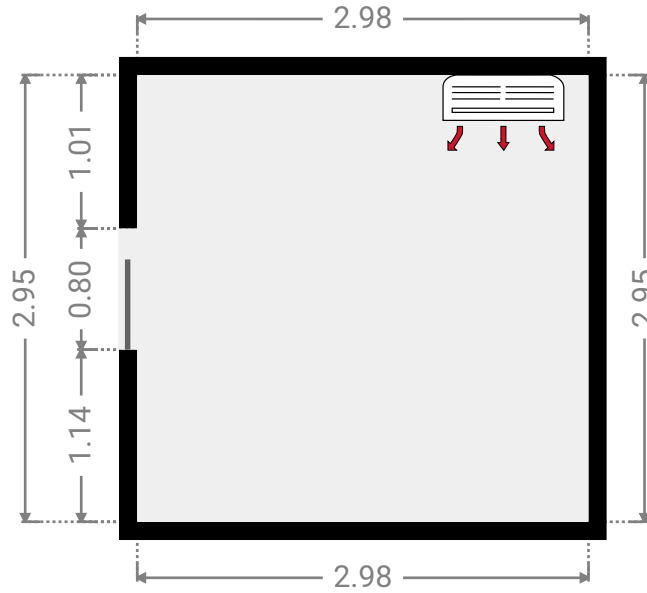
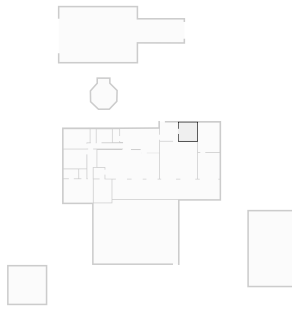

▼ Laundry Room
Ground Floor

WIDTH: 2.92 m • LENGTH: 2.96 m
AREA: 8.64 m² • PERIMETER: 11.76 m

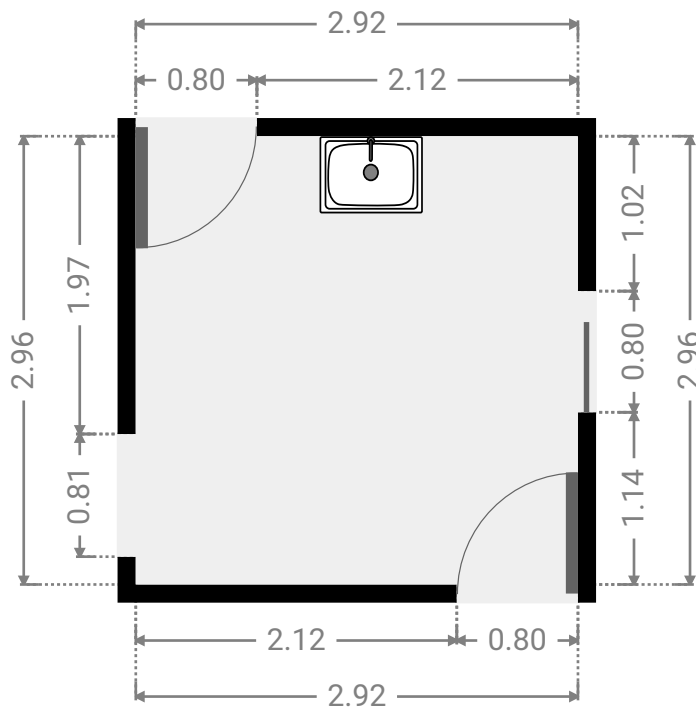
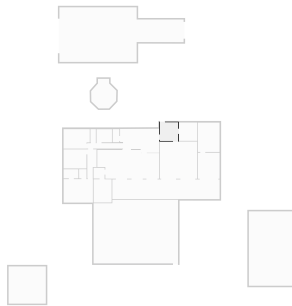

▼ Study
Ground Floor

WIDTH: 2.90 m • LENGTH: 3.75 m
AREA: 10.87 m² • PERIMETER: 13.30 m

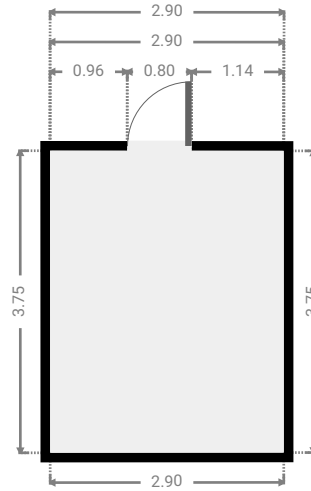
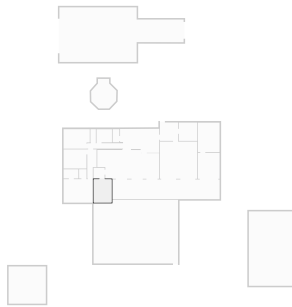

▼ Living Room
Ground Floor

WIDTH: 10.00 m • LENGTH: 4.65 m
AREA: 42.45 m² • PERIMETER: 29.28 m

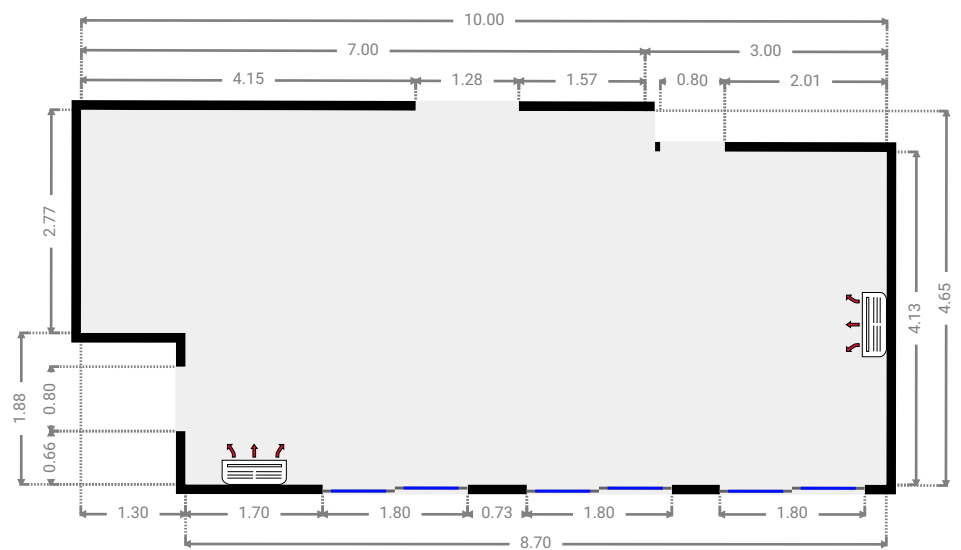
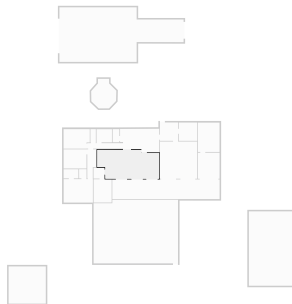

▼ **Master Bedroom**
Ground Floor

WIDTH: 4.71 m • LENGTH: 3.78 m
AREA: 17.80 m² • PERIMETER: 16.98 m

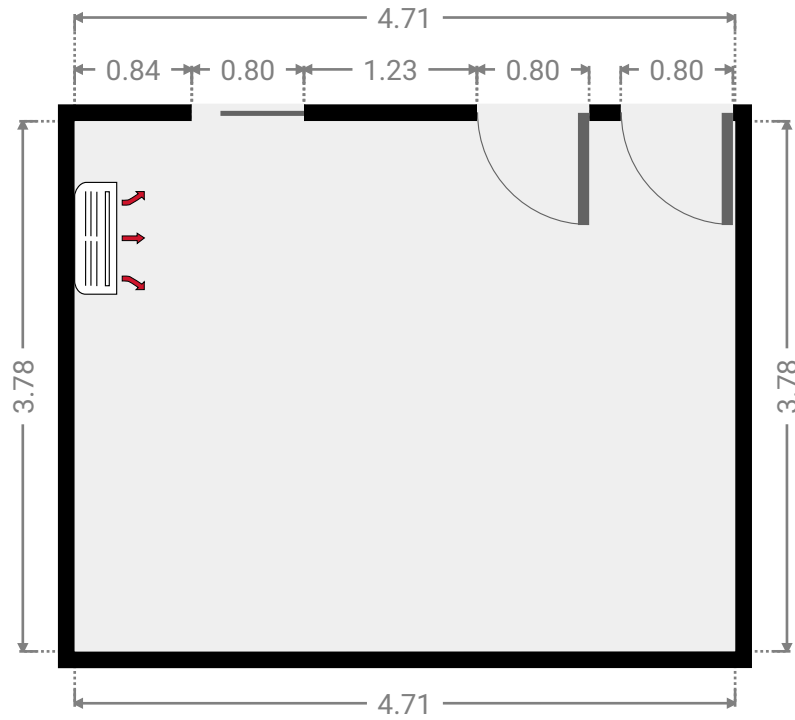
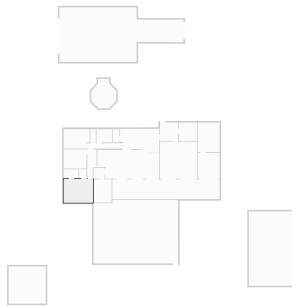

▼ **Closet**
Ground Floor

WIDTH: 1.20 m • LENGTH: 1.50 m
AREA: 1.78 m² • PERIMETER: 5.37 m

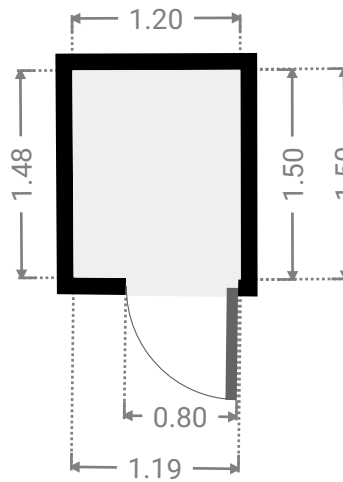
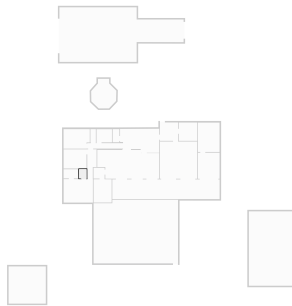

▼ Bathroom
Ground Floor

WIDTH: 2.38 m • LENGTH: 1.47 m
AREA: 3.50 m² • PERIMETER: 7.70 m

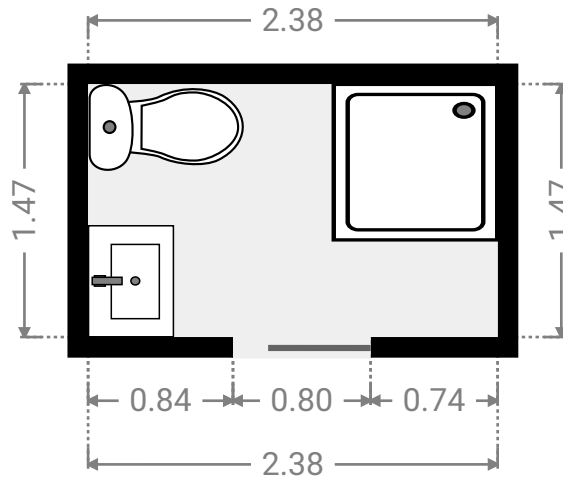
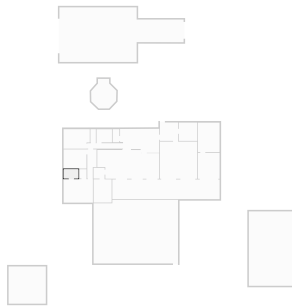

▼ Bedroom
Ground Floor

WIDTH: 3.68 m • LENGTH: 3.08 m
AREA: 11.34 m² • PERIMETER: 13.52 m

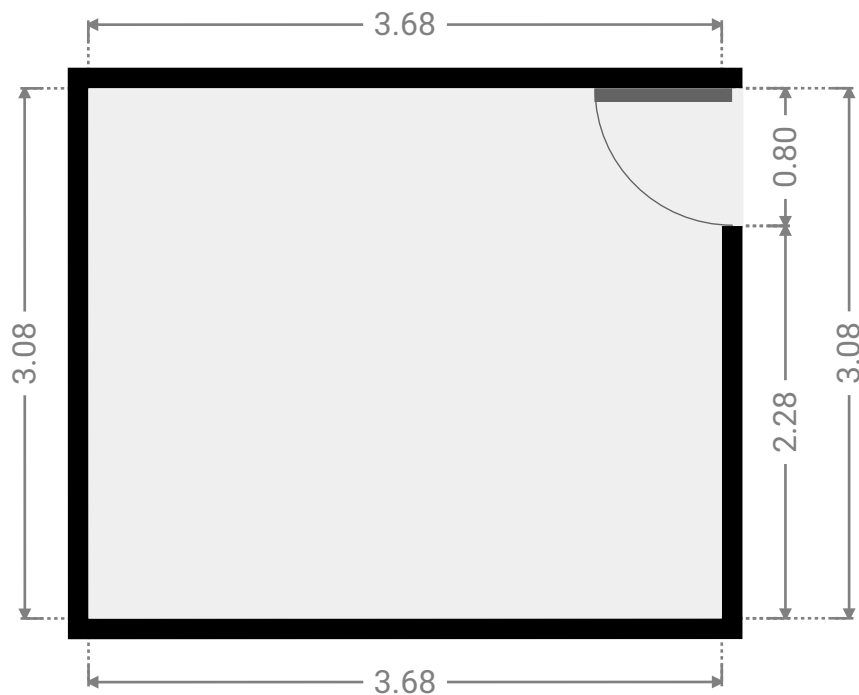
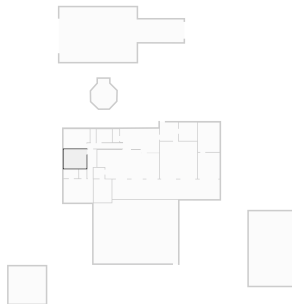

▼ **Hall**
Ground Floor

WIDTH: 1.49 m • LENGTH: 4.71 m
AREA: 5.91 m² • PERIMETER: 12.40 m

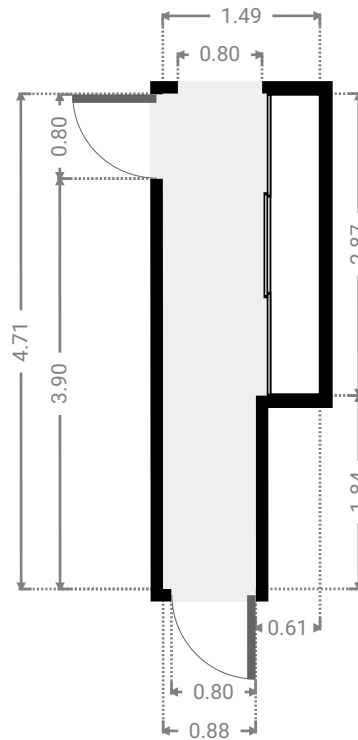
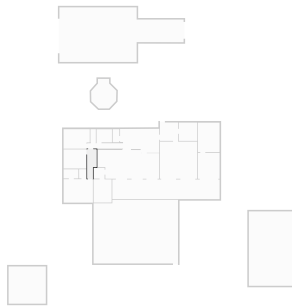

▼ **Bedroom**
Ground Floor

WIDTH: 4.22 m • LENGTH: 3.14 m
AREA: 12.73 m² • PERIMETER: 14.72 m

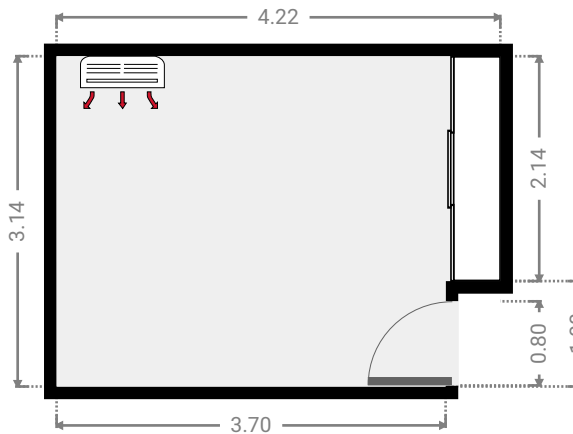
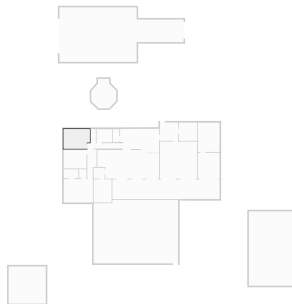

▼ **Toilet**
Ground Floor

WIDTH: 0.87 m • LENGTH: 2.13 m
AREA: 1.85 m² • PERIMETER: 6.00 m

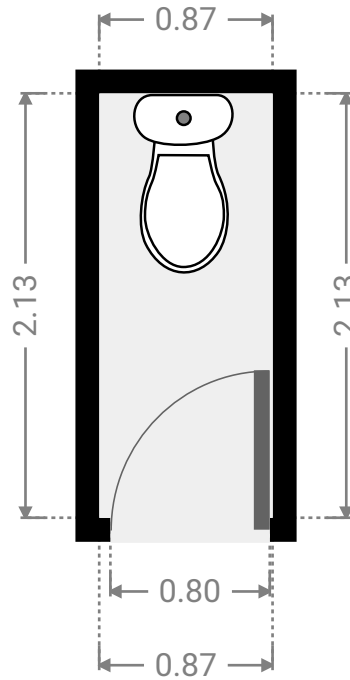
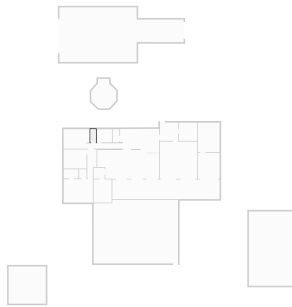

▼ **Bathroom**
Ground Floor

WIDTH: 2.48 m • LENGTH: 2.11 m
AREA: 5.23 m² • PERIMETER: 9.18 m

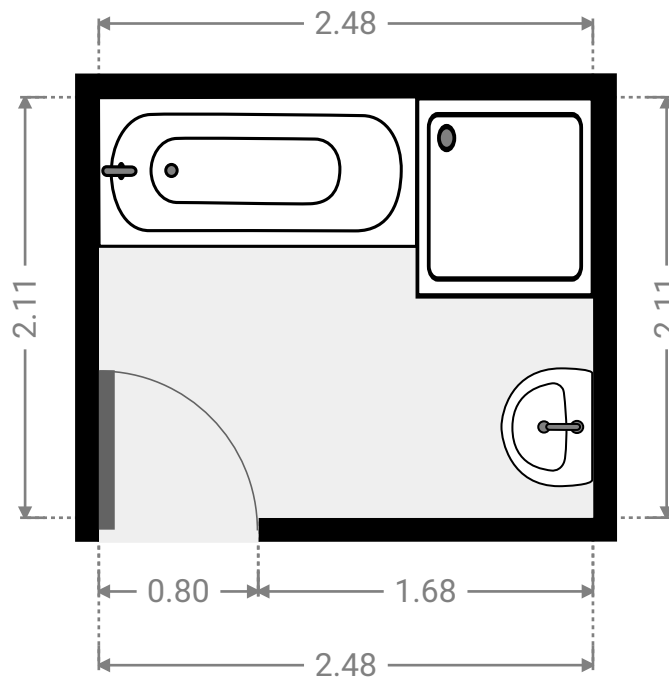
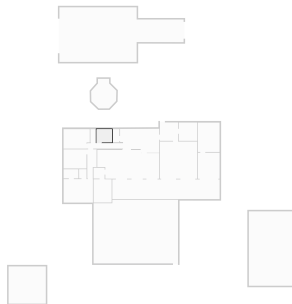

▼ **Closet**
Ground Floor

WIDTH: 1.08 m • LENGTH: 2.11 m
AREA: 2.28 m² • PERIMETER: 6.38 m

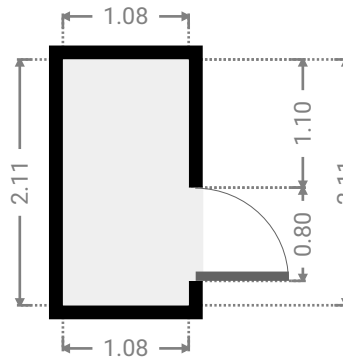
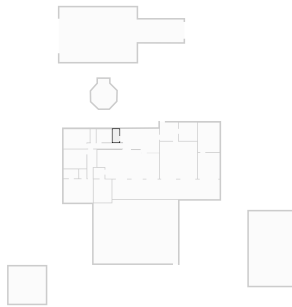

▼ **Hall**
Ground Floor

WIDTH: 5.66 m • LENGTH: 0.87 m
AREA: 4.93 m² • PERIMETER: 13.06 m

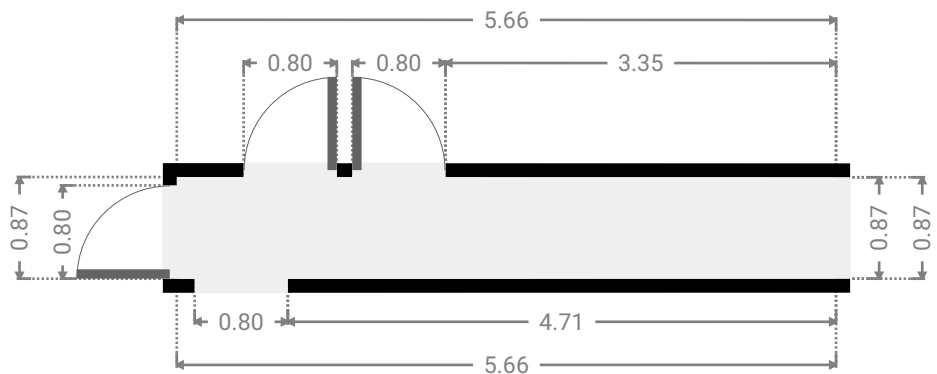
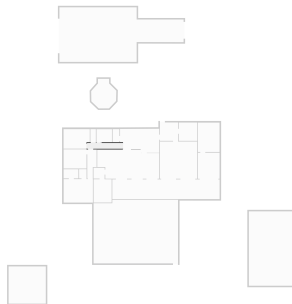

▼ **Kitchen**
Ground Floor

WIDTH: 6.33 m • LENGTH: 3.88 m
AREA: 21.79 m² • PERIMETER: 20.36 m

