

70 Sheehy Street

Created on
2021-06-03

Floors
1

▼ Ground Floor

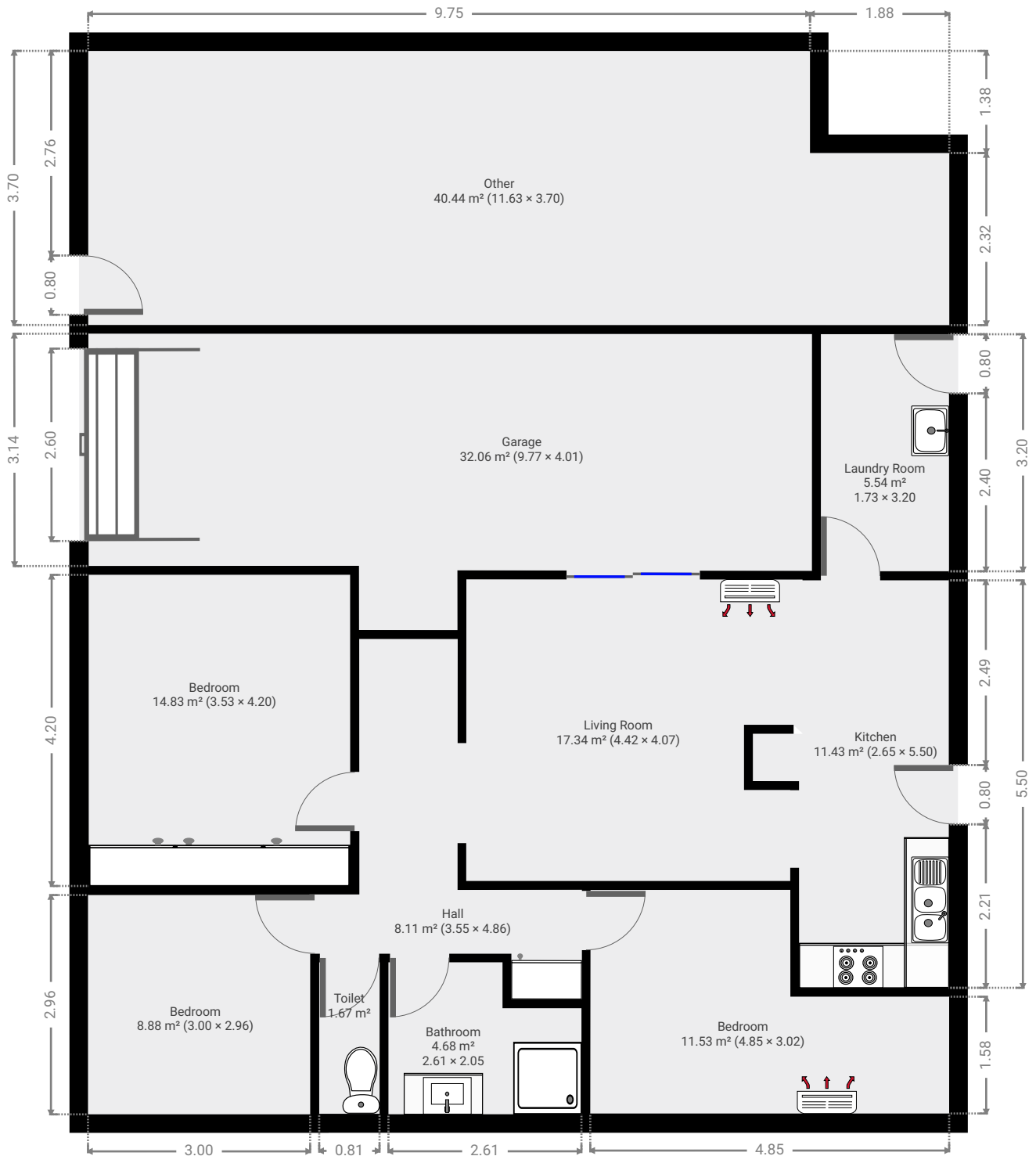

▼ Living Room
Ground Floor

WIDTH: 4.07 m • LENGTH: 4.42 m
AREA: 17.34 m² • PERIMETER: 18.23 m

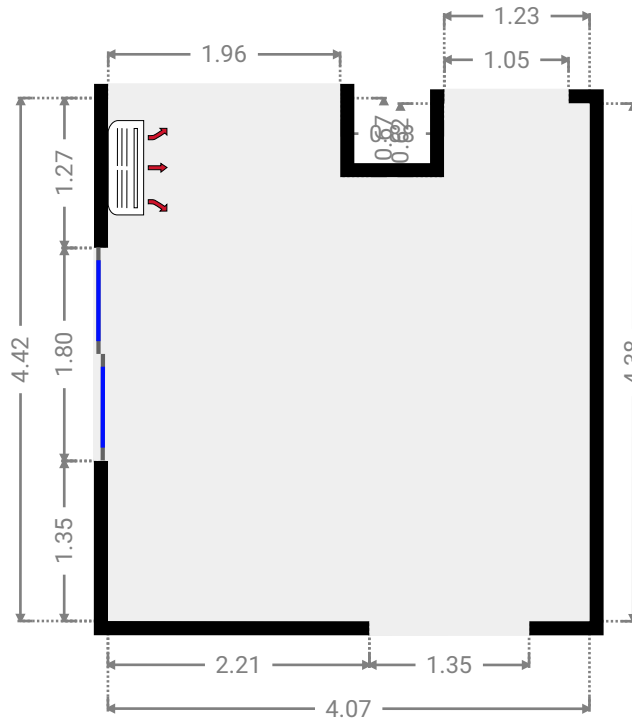
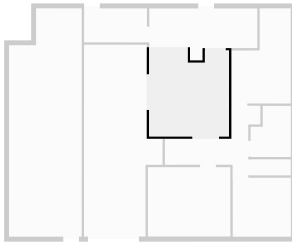

▼ Kitchen
Ground Floor

WIDTH: 5.50 m • LENGTH: 2.65 m
AREA: 11.43 m² • PERIMETER: 16.29 m

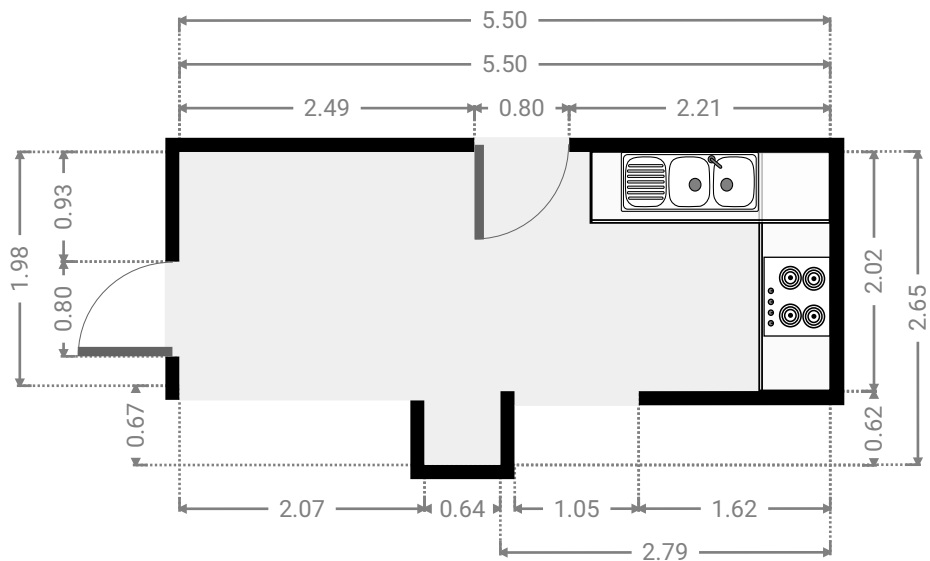

▼ Laundry Room
Ground Floor

WIDTH: 3.20 m • LENGTH: 1.73 m
AREA: 5.54 m² • PERIMETER: 9.86 m

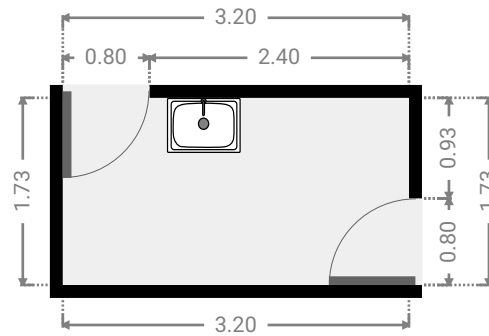
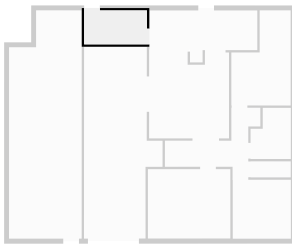

▼ Hall
Ground Floor

WIDTH: 4.86 m • LENGTH: 3.55 m
AREA: 8.11 m² • PERIMETER: 16.84 m

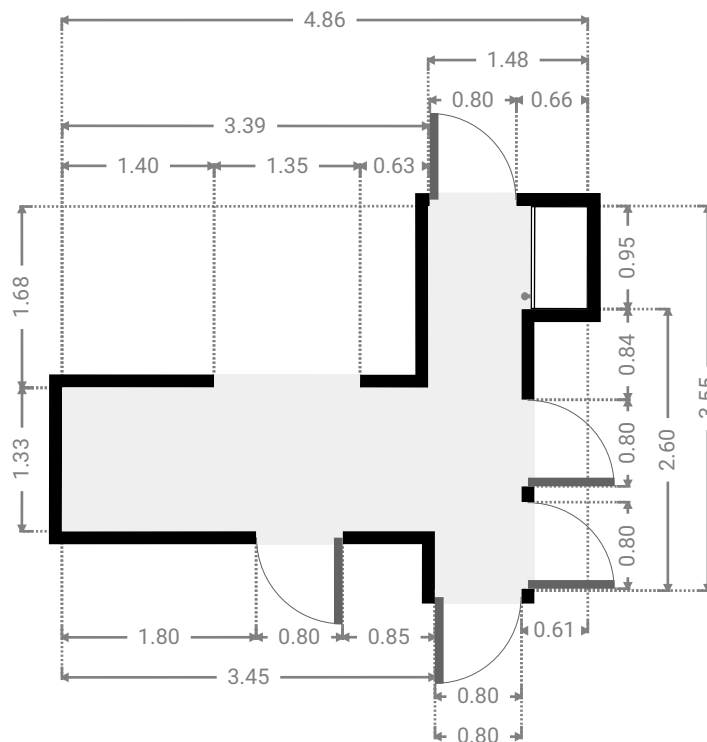

▼ **Bedroom**
Ground Floor

WIDTH: 2.96 m • LENGTH: 3.00 m
AREA: 8.88 m² • PERIMETER: 11.92 m

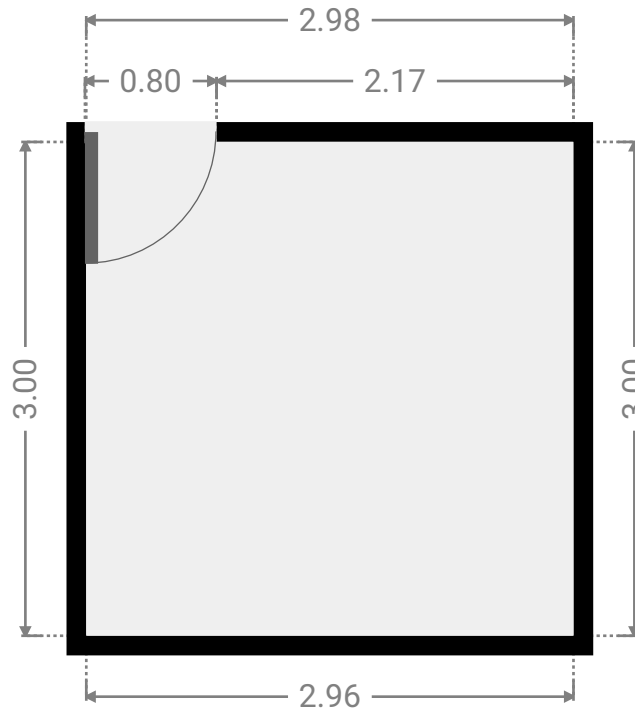

▼ **Toilet**
Ground Floor

WIDTH: 2.04 m • LENGTH: 0.82 m
AREA: 1.67 m² • PERIMETER: 5.72 m

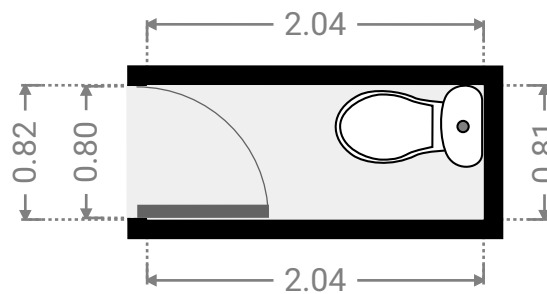

▼ **Bathroom**
Ground Floor

WIDTH: 2.05 m • LENGTH: 2.61 m
AREA: 4.68 m² • PERIMETER: 9.31 m

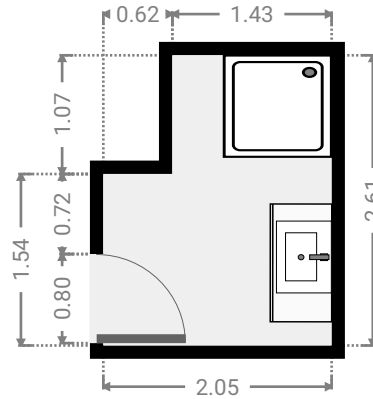
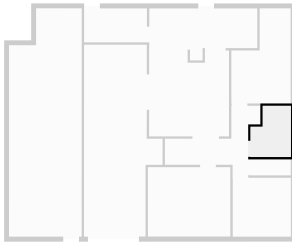

▼ **Bedroom**
Ground Floor

WIDTH: 3.02 m • LENGTH: 4.85 m
AREA: 11.53 m² • PERIMETER: 15.73 m

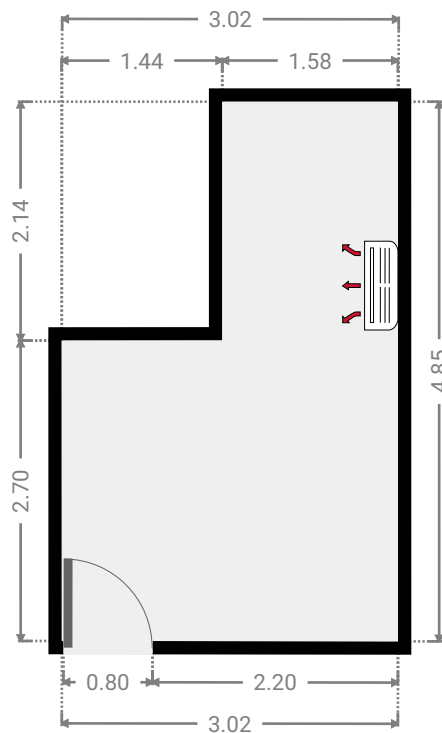
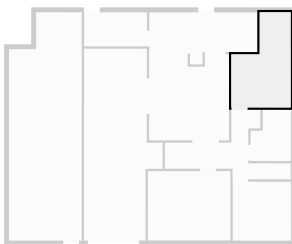

▼ **Bedroom**
Ground Floor

WIDTH: 4.20 m • LENGTH: 3.53 m
AREA: 14.83 m² • PERIMETER: 15.46 m

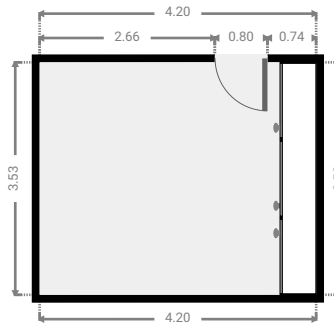
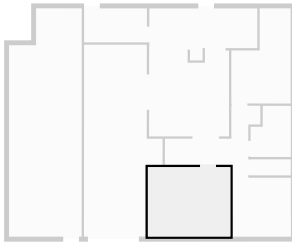

▼ **Garage**
Ground Floor

WIDTH: 4.01 m • LENGTH: 9.77 m
AREA: 32.06 m² • PERIMETER: 27.55 m

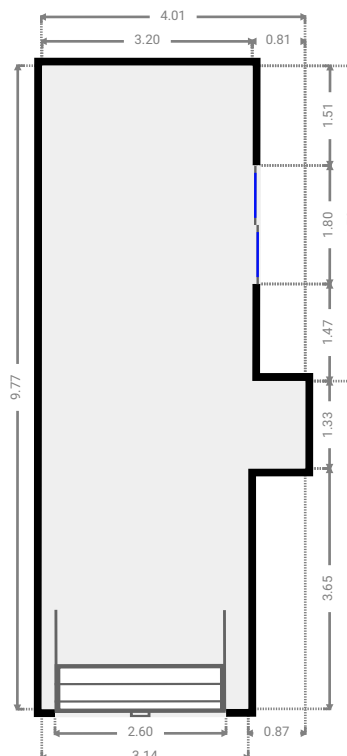
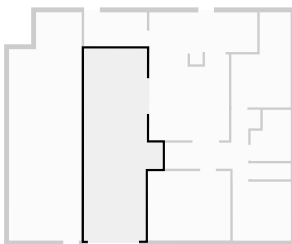

▼ Other
Ground Floor

WIDTH: 3.70 m • LENGTH: 11.63 m
AREA: 40.44 m² • PERIMETER: 30.66 m

