

7 Wiggington Street

SUBMITTED BY
Janelle Casey
stockers@cqoz.com

CREATED ON
2021-11-01

Floors
2

▼ Ground Floor

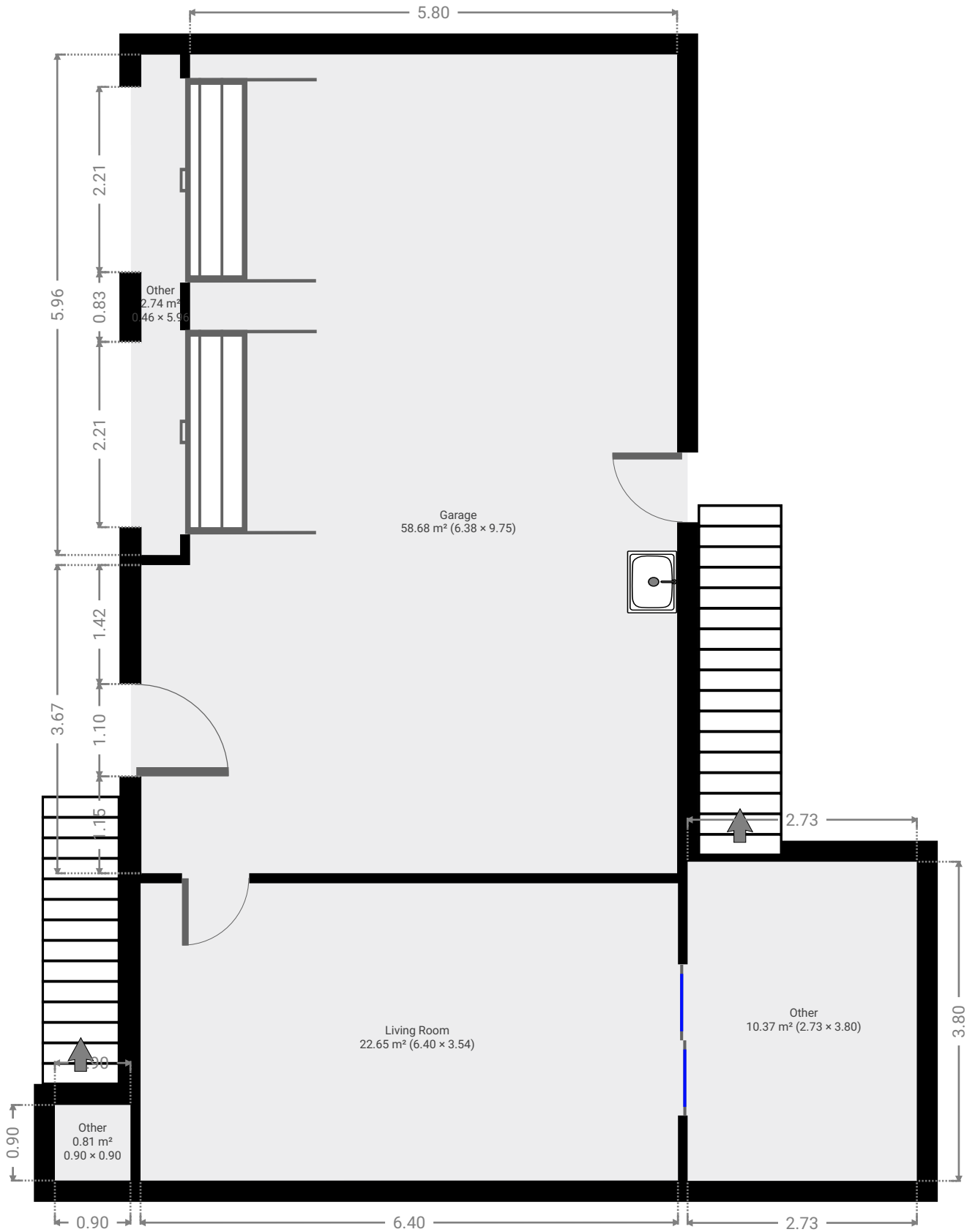

▼ **Living Room**
Ground Floor

WIDTH: 3.54 m • LENGTH: 6.40 m
AREA: 22.65 m² • PERIMETER: 19.88 m

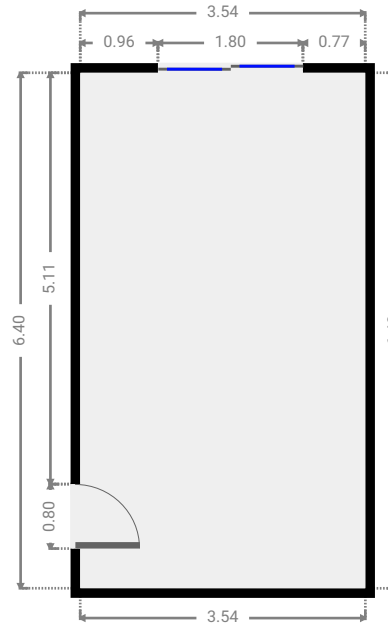
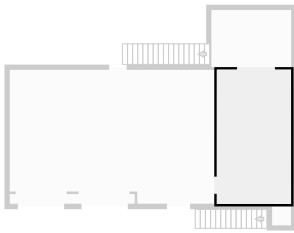

▼ **Garage**
Ground Floor

WIDTH: 9.75 m • LENGTH: 6.38 m
AREA: 58.68 m² • PERIMETER: 32.26 m

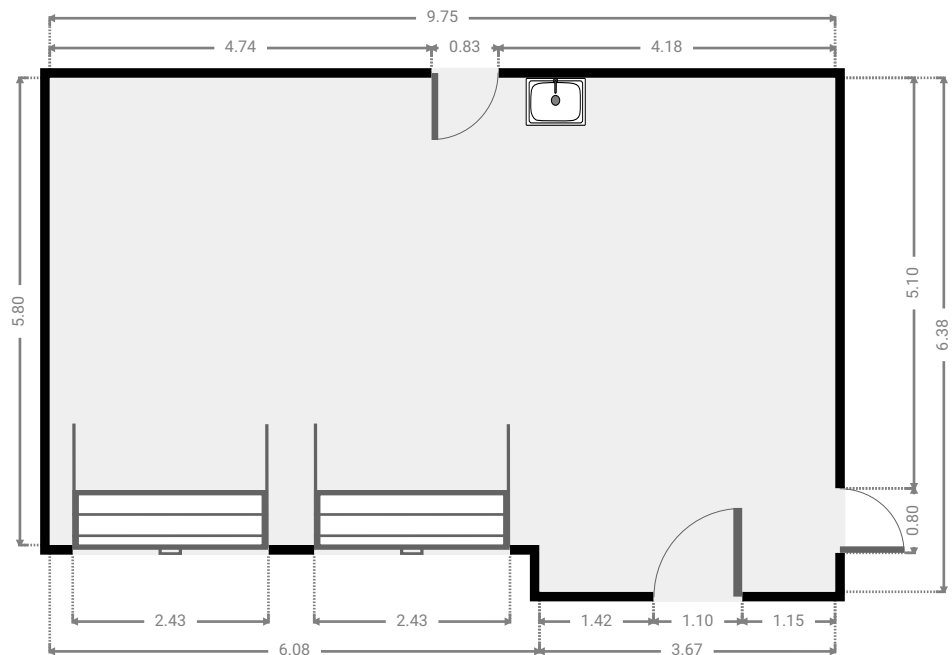
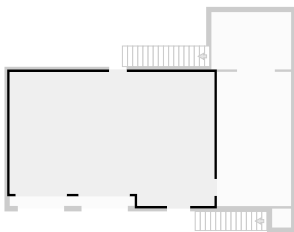

▼ Other
Ground Floor

WIDTH: 3.80 m • LENGTH: 2.73 m
AREA: 10.37 m² • PERIMETER: 13.06 m

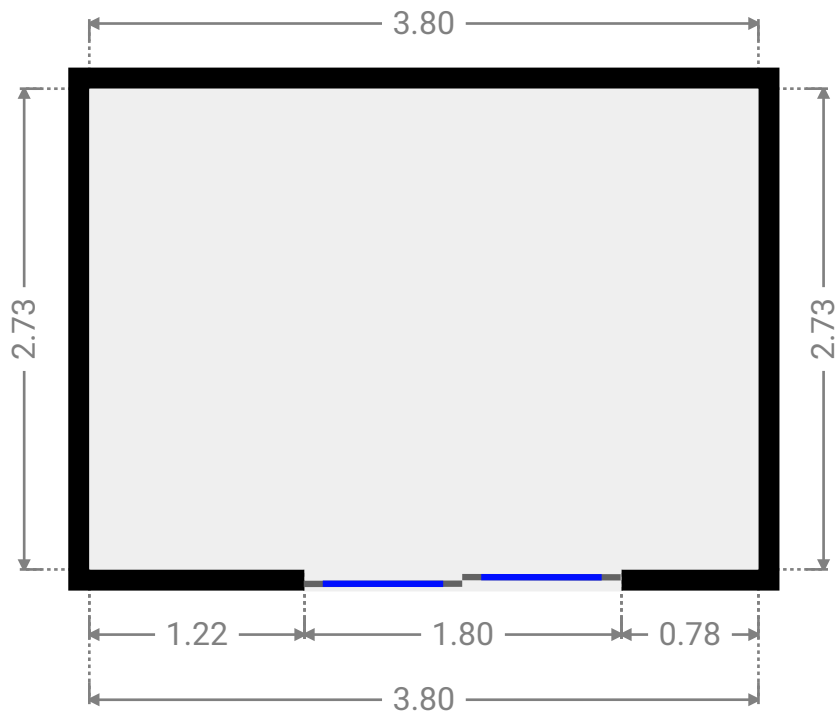
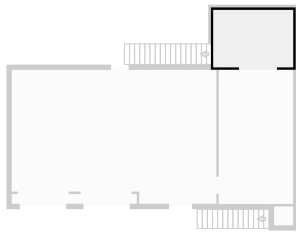

▼ Other
Ground Floor

WIDTH: 0.90 m • LENGTH: 0.90 m
AREA: 0.81 m² • PERIMETER: 3.60 m

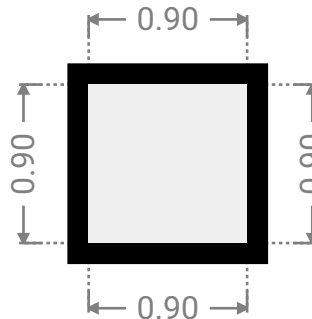
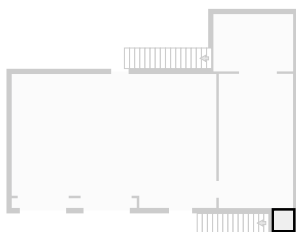

▼ Other
Ground Floor

WIDTH: 5.96 m • LENGTH: 0.46 m
AREA: 2.74 m² • PERIMETER: 12.84 m

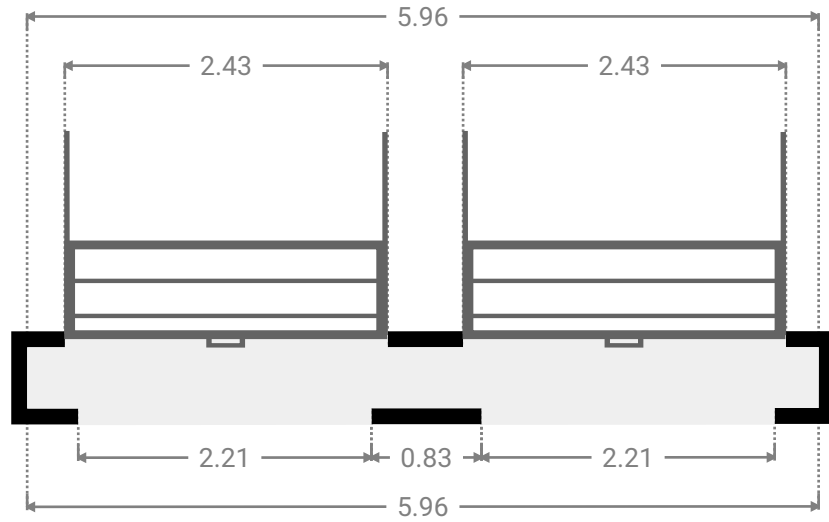
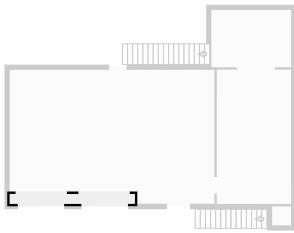

▼ 1st Floor

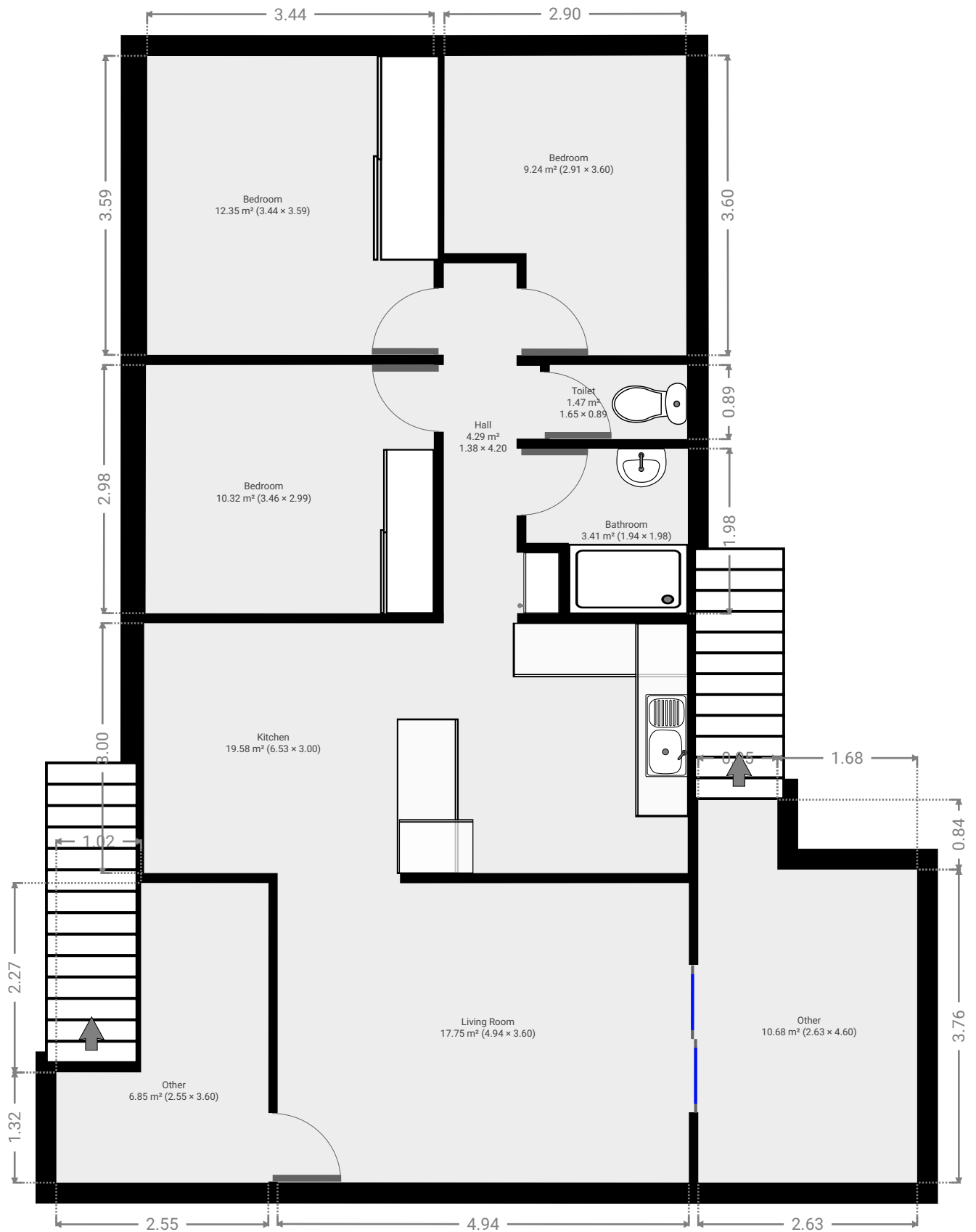

THIS FLOORPLAN IS PROVIDED WITHOUT WARRANTY OF ANY KIND. SENSOPIA DISCLAIMS ANY WARRANTY INCLUDING, WITHOUT LIMITATION, SATISFACTORY QUALITY OR ACCURACY OF DIMENSIONS.

0 1 2 3m

▼ **Living Room**
1st Floor

WIDTH: 3.60 m • LENGTH: 4.94 m
AREA: 17.75 m² • PERIMETER: 17.07 m

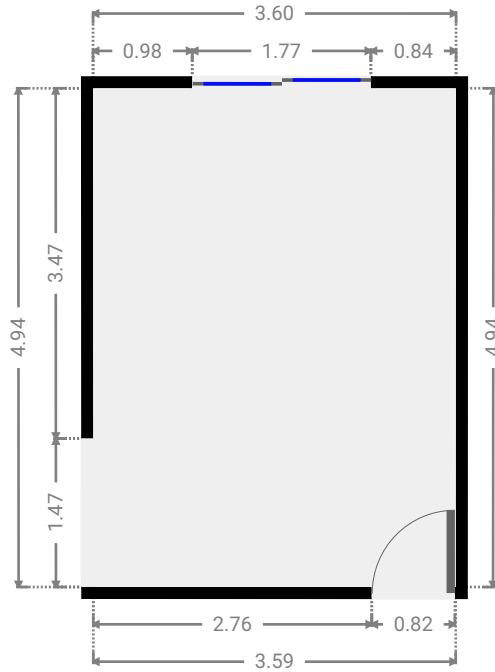
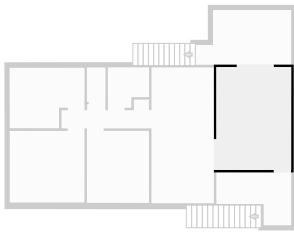

▼ **Kitchen**
1st Floor

WIDTH: 3.00 m • LENGTH: 6.53 m
AREA: 19.58 m² • PERIMETER: 19.06 m

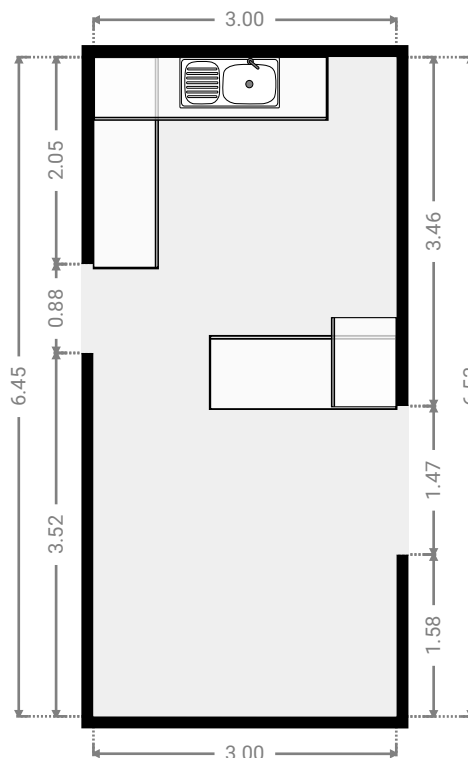
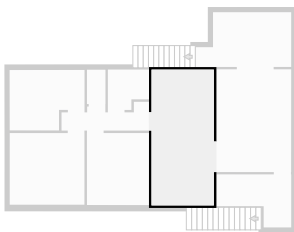

▼ **Hall**
1st Floor

WIDTH: 4.20 m • LENGTH: 1.38 m
AREA: 4.29 m² • PERIMETER: 11.73 m

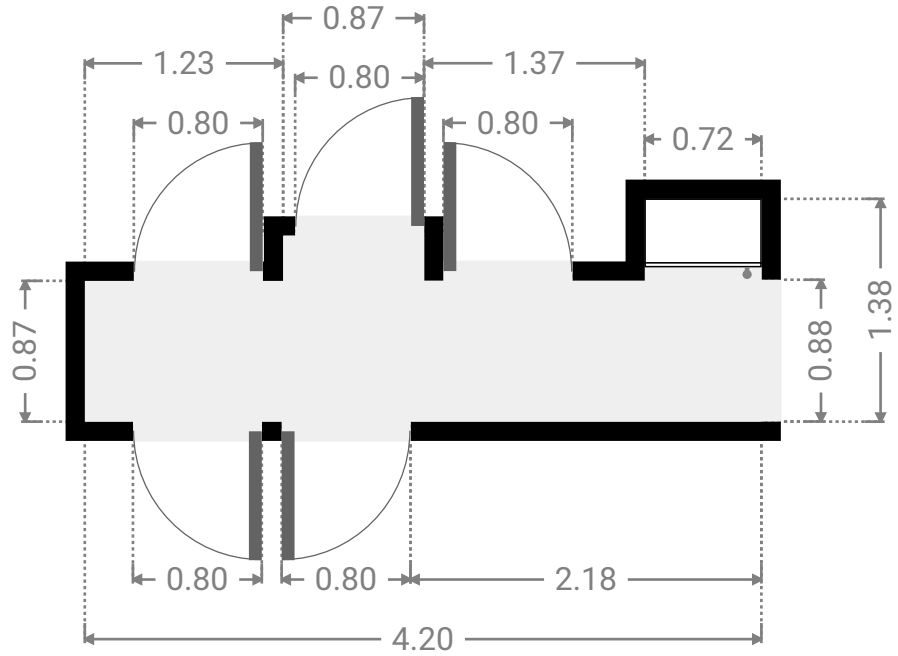
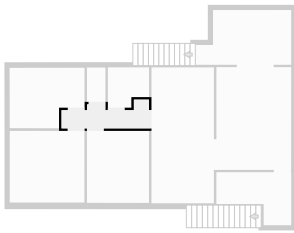

▼ **Bathroom**
1st Floor

WIDTH: 1.98 m • LENGTH: 1.94 m
AREA: 3.41 m² • PERIMETER: 7.84 m

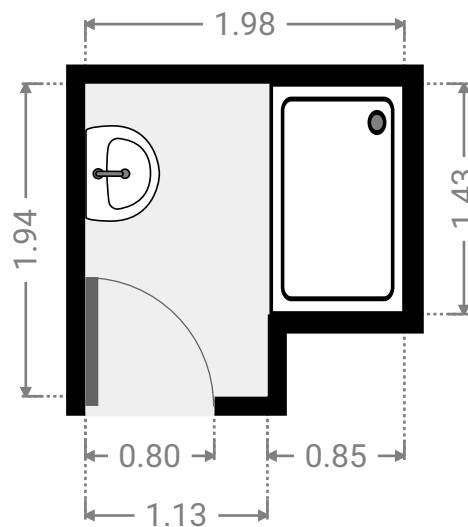
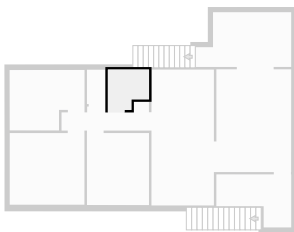

▼ **Toilet**
1st Floor

WIDTH: 0.89 m • LENGTH: 1.65 m
AREA: 1.47 m² • PERIMETER: 5.08 m

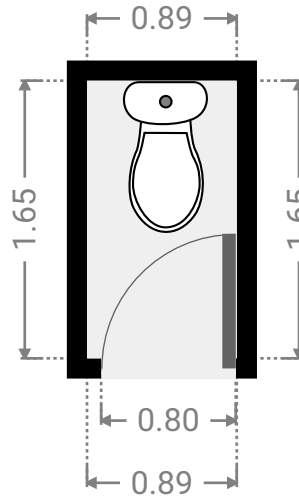
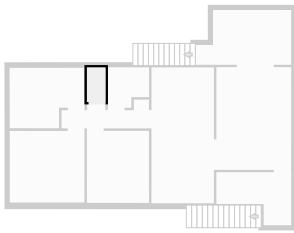

▼ **Bedroom**
1st Floor

WIDTH: 3.60 m • LENGTH: 2.91 m
AREA: 9.24 m² • PERIMETER: 13.00 m

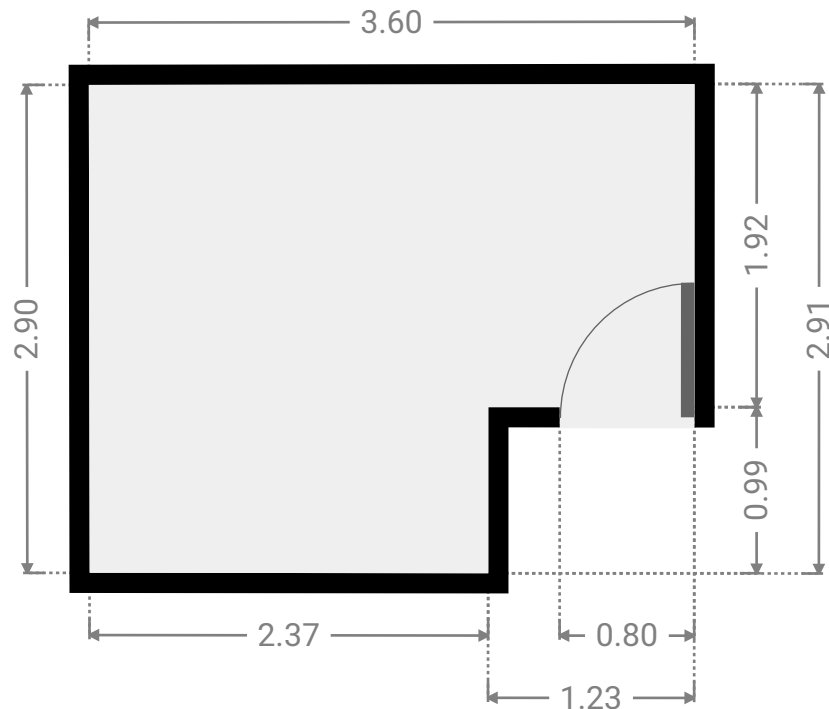
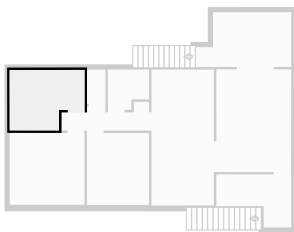

▼ **Bedroom**
1st Floor

WIDTH: 3.59 m • LENGTH: 3.44 m
AREA: 12.35 m² • PERIMETER: 14.06 m

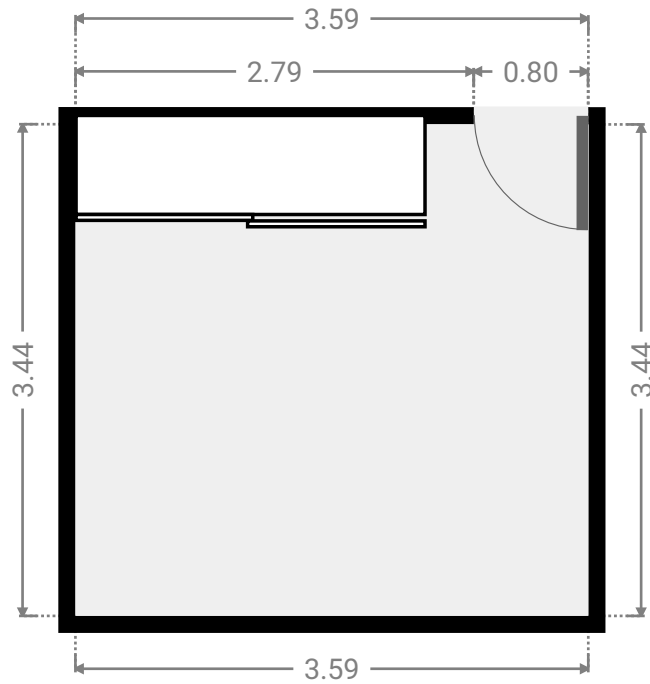
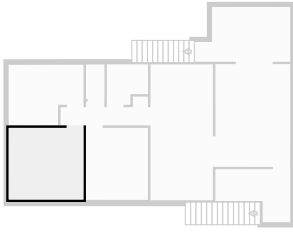

▼ **Bedroom**
1st Floor

WIDTH: 2.99 m • LENGTH: 3.46 m
AREA: 10.32 m² • PERIMETER: 12.89 m

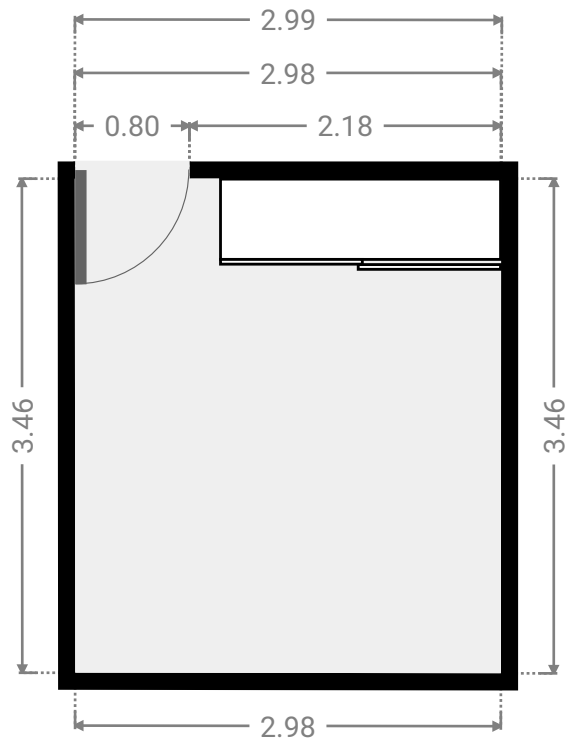
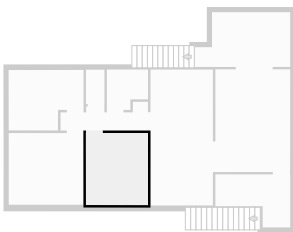

▼ Other
1st Floor

WIDTH: 3.60 m • LENGTH: 2.55 m
AREA: 6.85 m² • PERIMETER: 12.29 m

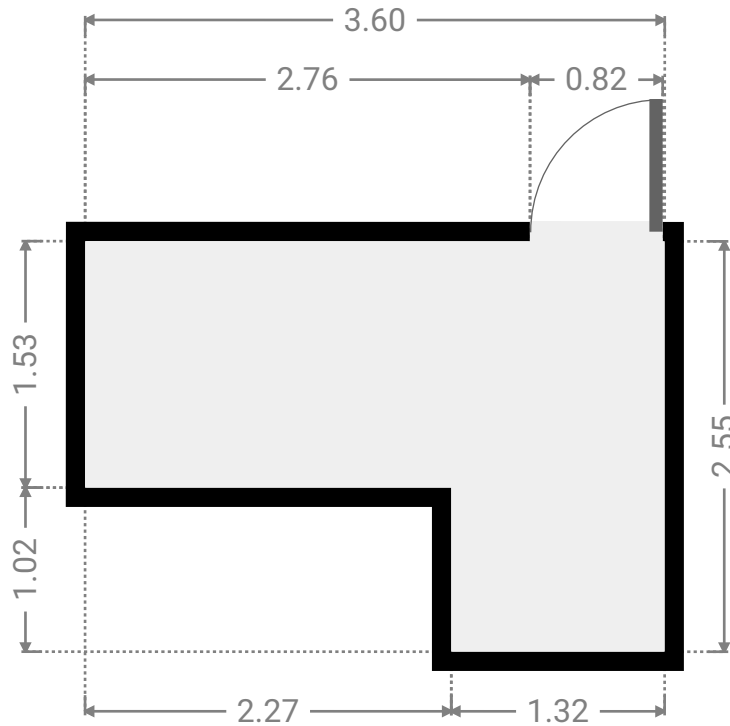
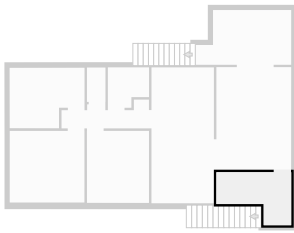

▼ Other
1st Floor

WIDTH: 4.60 m • LENGTH: 2.63 m
AREA: 10.68 m² • PERIMETER: 14.46 m

