

# 69 Kershaw Street

Created on  
2021-02-15

Floors  
2

▼ Ground Floor

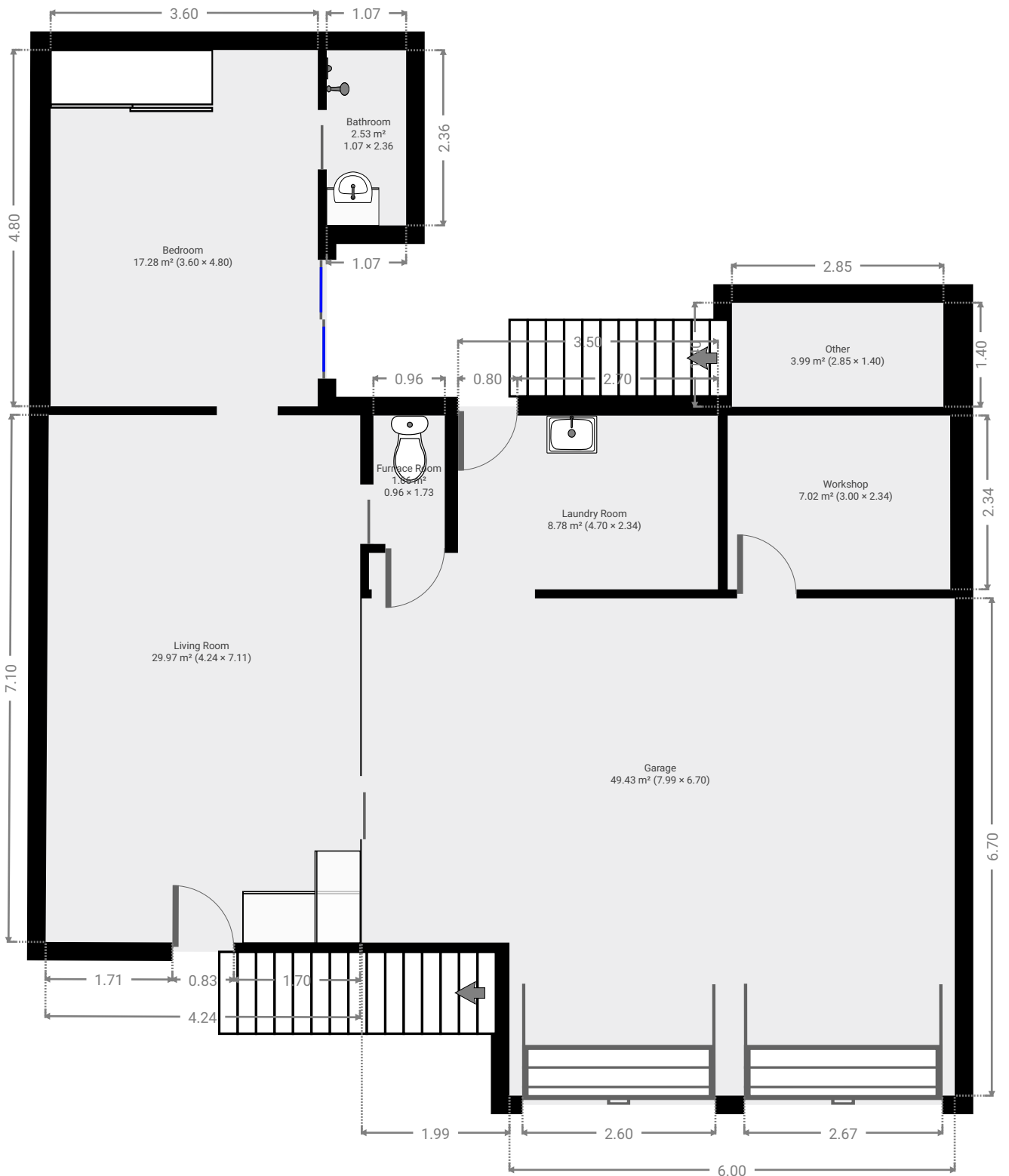

▼ Living Room  
Ground Floor

WIDTH: 4.24 m • LENGTH: 7.11 m  
AREA: 29.97 m<sup>2</sup> • PERIMETER: 22.65 m

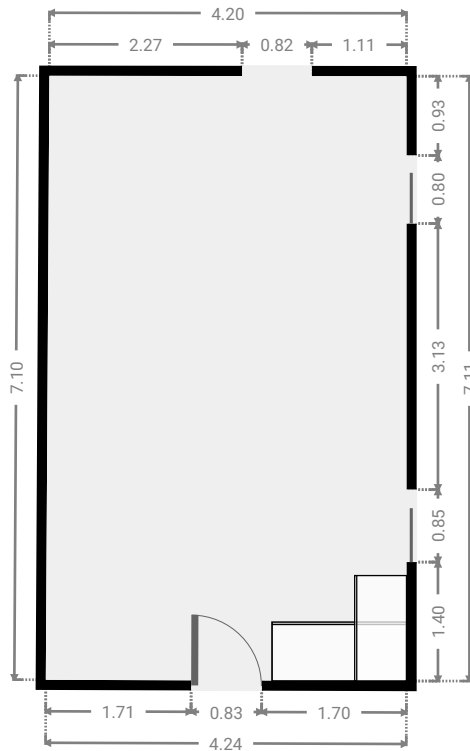
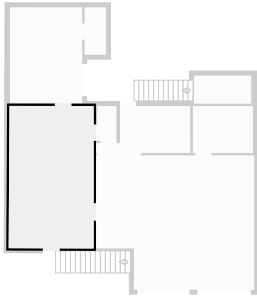

▼ Bedroom  
Ground Floor

WIDTH: 3.60 m • LENGTH: 4.80 m  
AREA: 17.28 m<sup>2</sup> • PERIMETER: 16.80 m

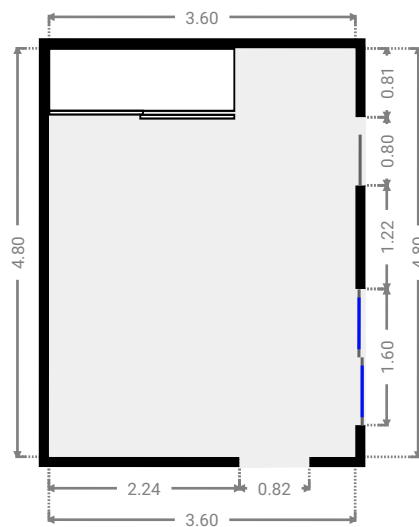
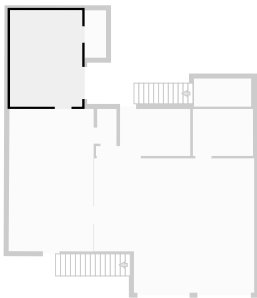

▼ **Bathroom**  
Ground Floor

WIDTH: 1.07 m • LENGTH: 2.36 m  
AREA: 2.53 m<sup>2</sup> • PERIMETER: 6.86 m

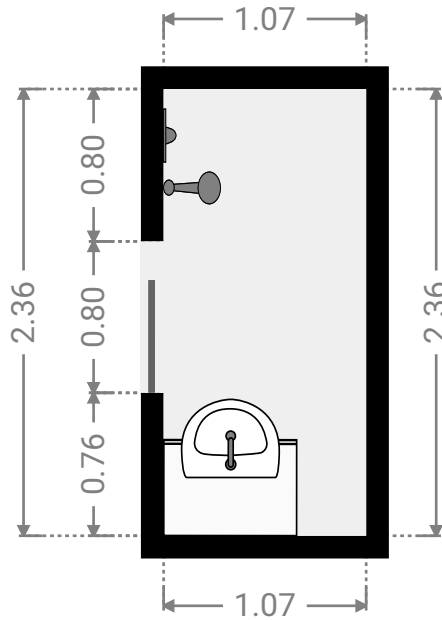
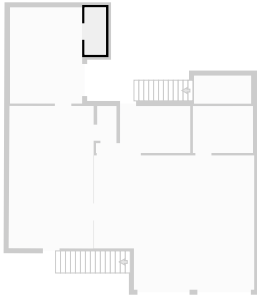

▼ **Furnace Room**  
Ground Floor

WIDTH: 0.96 m • LENGTH: 1.73 m  
AREA: 1.66 m<sup>2</sup> • PERIMETER: 5.38 m

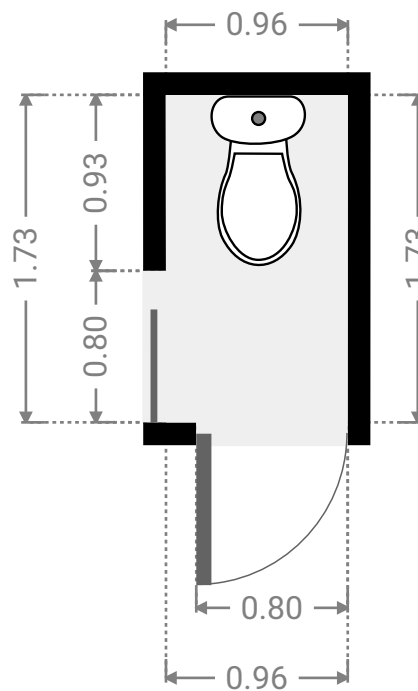
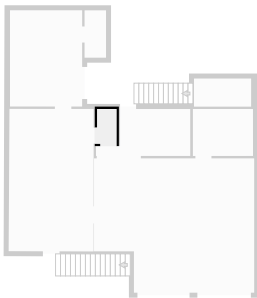

▼ Laundry Room  
Ground Floor

WIDTH: 4.70 m • LENGTH: 2.34 m  
AREA: 8.78 m<sup>2</sup> • PERIMETER: 14.08 m

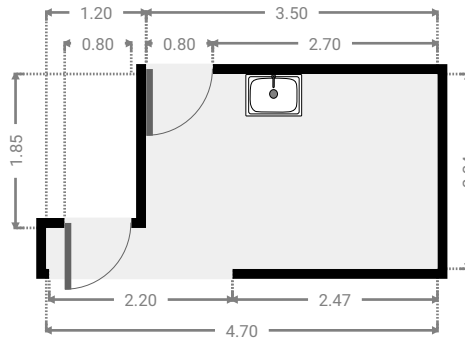
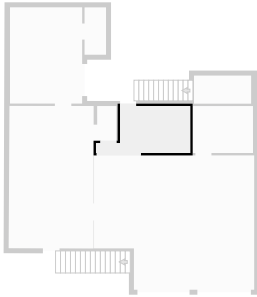

▼ Garage  
Ground Floor

WIDTH: 7.99 m • LENGTH: 6.70 m  
AREA: 49.43 m<sup>2</sup> • PERIMETER: 29.38 m

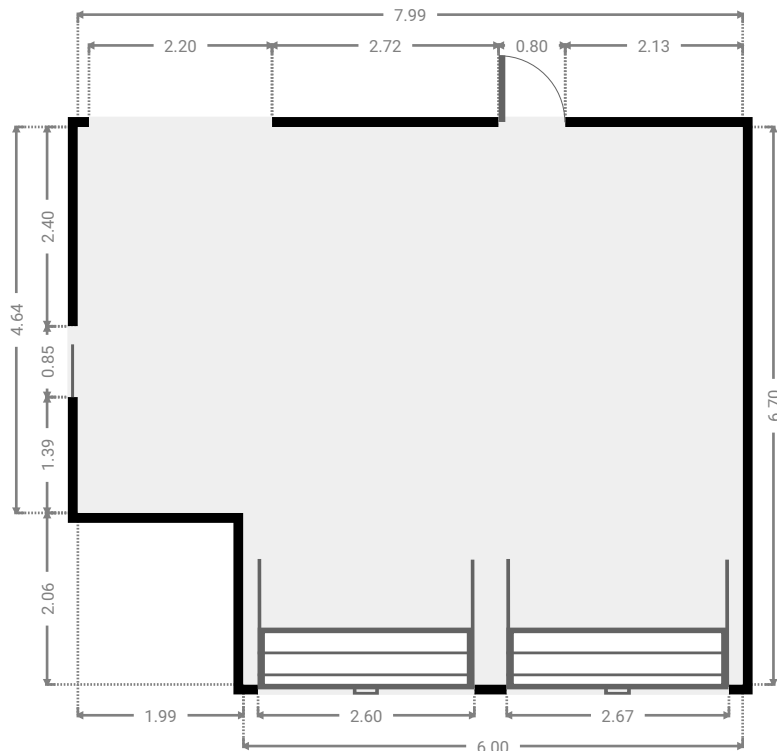
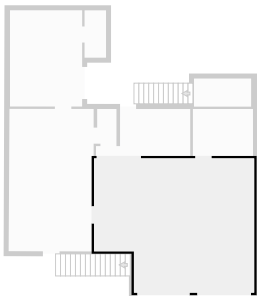

▼ **Workshop**  
Ground Floor

WIDTH: 3.00 m • LENGTH: 2.34 m  
AREA: 7.02 m<sup>2</sup> • PERIMETER: 10.68 m

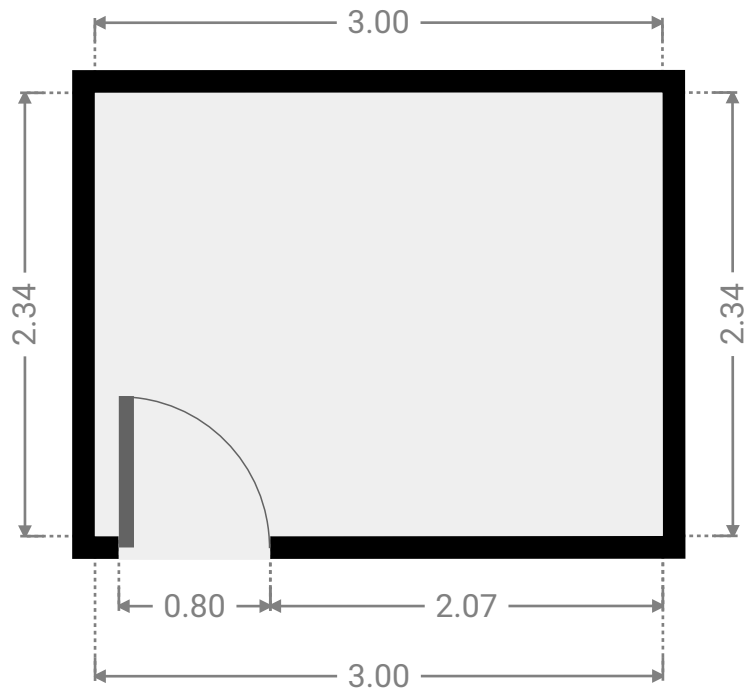
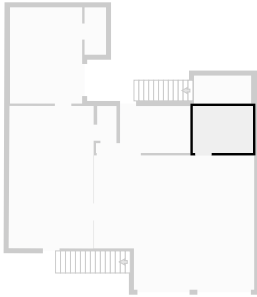

▼ **Other**  
Ground Floor

WIDTH: 2.85 m • LENGTH: 1.40 m  
AREA: 3.99 m<sup>2</sup> • PERIMETER: 8.50 m

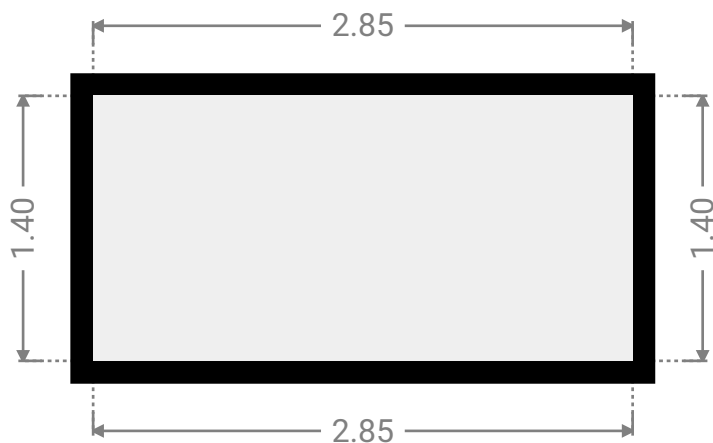
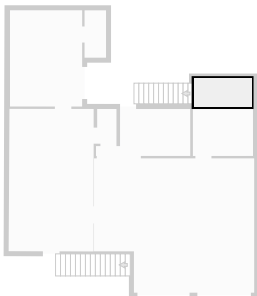

▼ 1st Floor



▼ Living Room  
1st Floor

WIDTH: 5.92 m • LENGTH: 3.75 m  
AREA: 22.20 m<sup>2</sup> • PERIMETER: 19.34 m

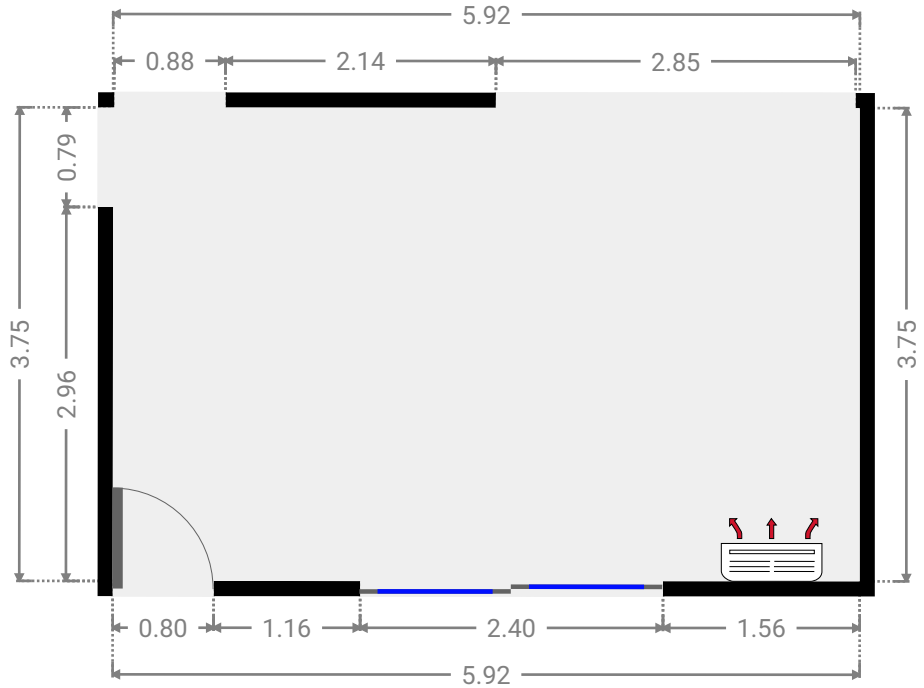
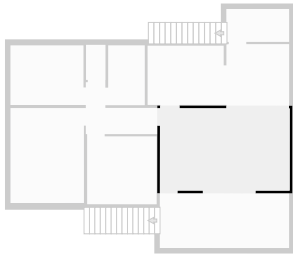

▼ Dining Room  
1st Floor

WIDTH: 2.86 m • LENGTH: 2.84 m  
AREA: 8.12 m<sup>2</sup> • PERIMETER: 11.40 m

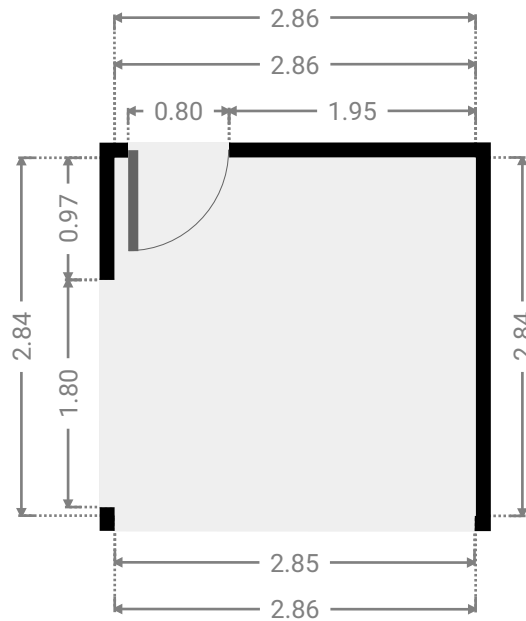
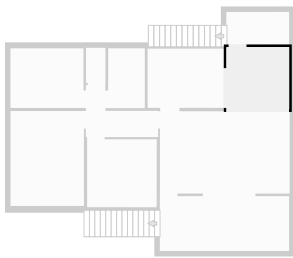



▼ Kitchen  
1st Floor

WIDTH: 3.47 m • LENGTH: 2.70 m  
AREA: 9.37 m<sup>2</sup> • PERIMETER: 12.34 m

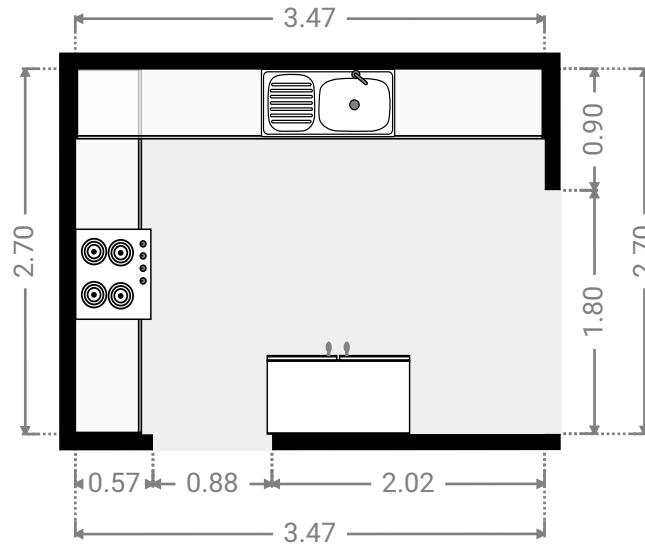
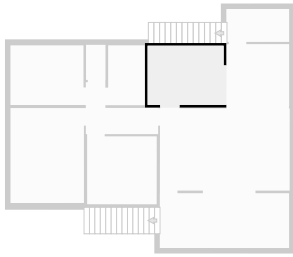

▼ Hall  
1st Floor

WIDTH: 3.30 m • LENGTH: 2.37 m  
AREA: 4.99 m<sup>2</sup> • PERIMETER: 11.34 m

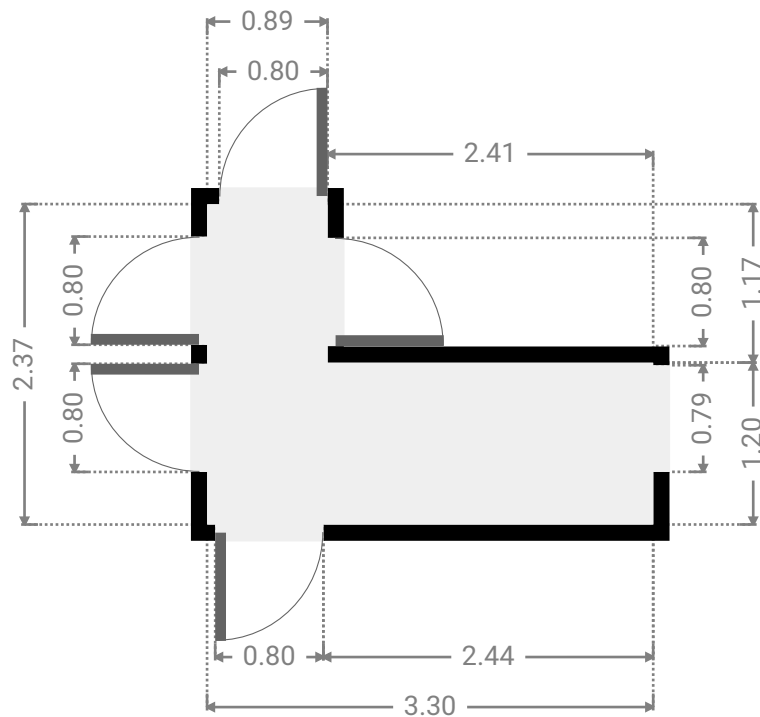
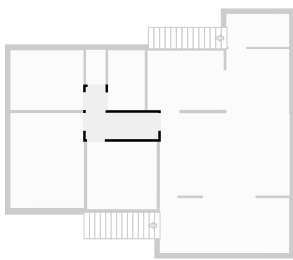

▼ **Bathroom**  
1st Floor

WIDTH: 1.67 m • LENGTH: 2.73 m  
AREA: 4.56 m<sup>2</sup> • PERIMETER: 8.80 m

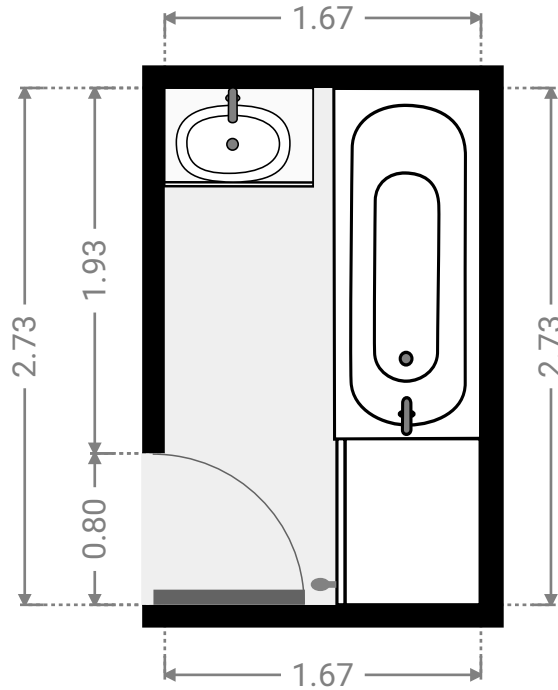
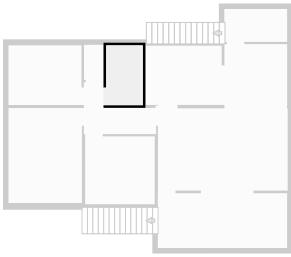

▼ **Toilet**  
1st Floor

WIDTH: 0.89 m • LENGTH: 1.60 m  
AREA: 1.42 m<sup>2</sup> • PERIMETER: 4.98 m

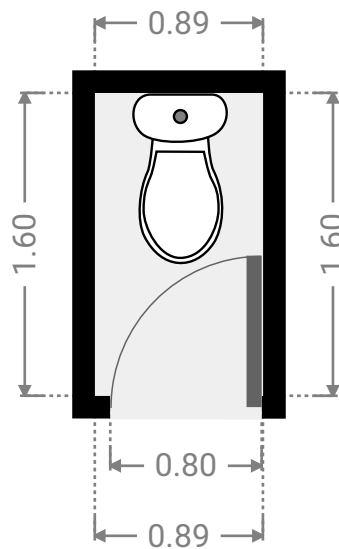
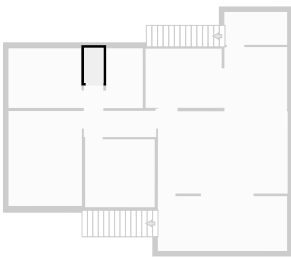

▼ **Bedroom**  
1st Floor

WIDTH: 3.33 m • LENGTH: 2.72 m  
AREA: 9.06 m<sup>2</sup> • PERIMETER: 12.10 m

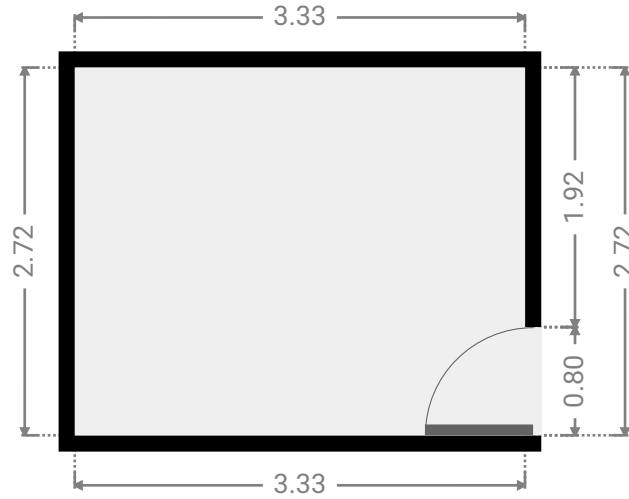
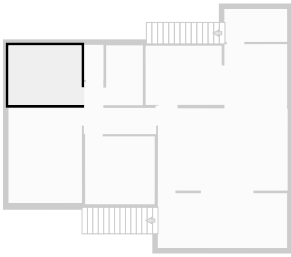

▼ **Bedroom**  
1st Floor

WIDTH: 3.35 m • LENGTH: 4.33 m  
AREA: 14.50 m<sup>2</sup> • PERIMETER: 15.36 m

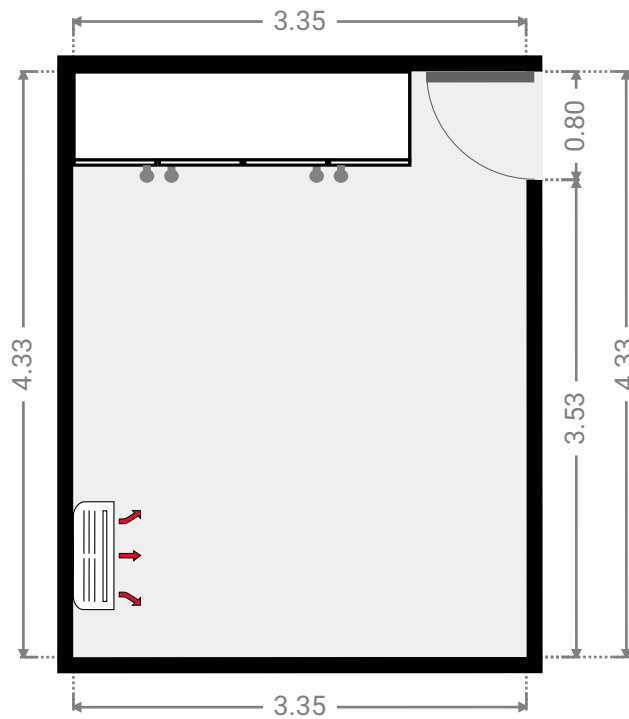
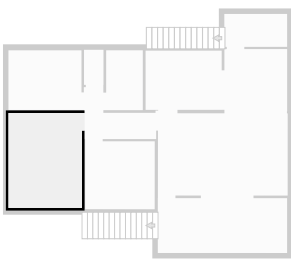

▼ **Bedroom**  
1st Floor

WIDTH: 3.17 m • LENGTH: 3.10 m  
AREA: 9.83 m<sup>2</sup> • PERIMETER: 12.54 m

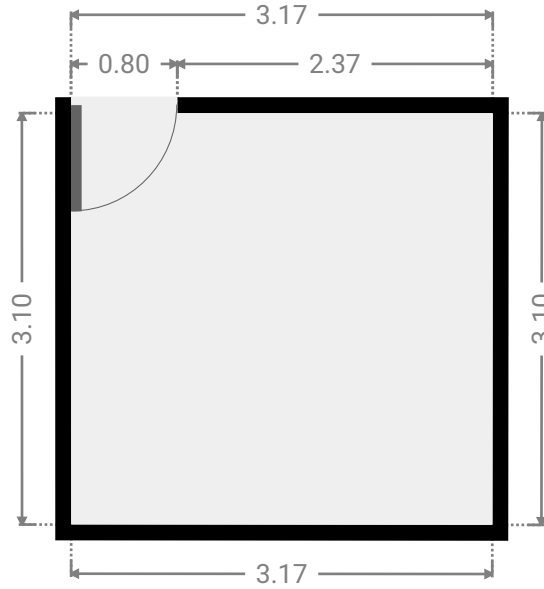
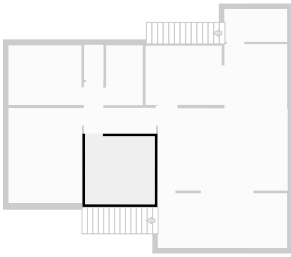

▼ **Other**  
1st Floor

WIDTH: 5.90 m • LENGTH: 2.50 m  
AREA: 14.75 m<sup>2</sup> • PERIMETER: 16.80 m

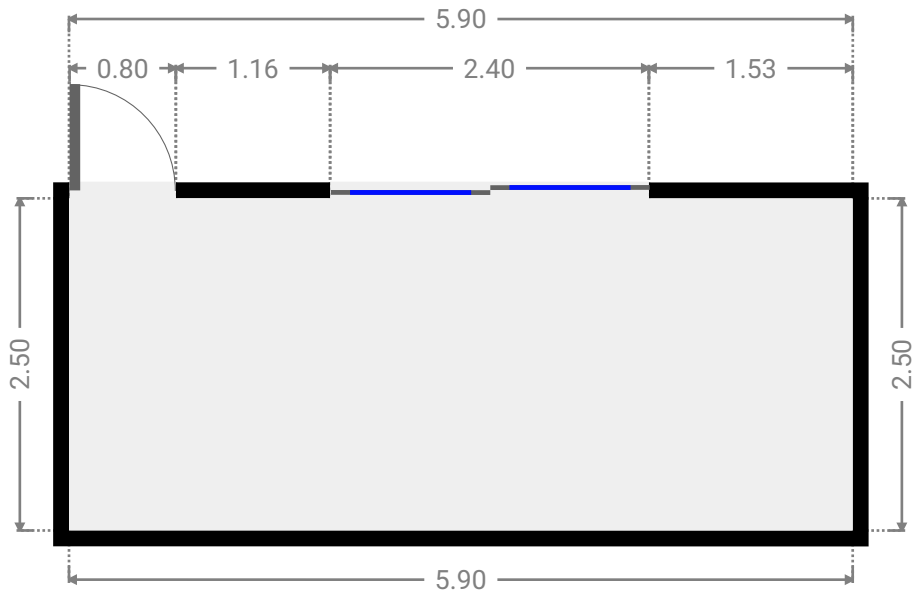
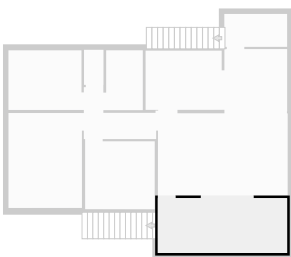

▼ Other  
1st Floor

WIDTH: 2.86 m • LENGTH: 1.50 m  
AREA: 4.30 m<sup>2</sup> • PERIMETER: 8.73 m

