

# 65 Alexandra Street

**SUBMITTED BY**

Ray White Rockhampton Casey  
stockers@cqoz.com

---

**CREATED ON**

2022-02-16

---

**Floors**

2

---

▼ Ground Floor

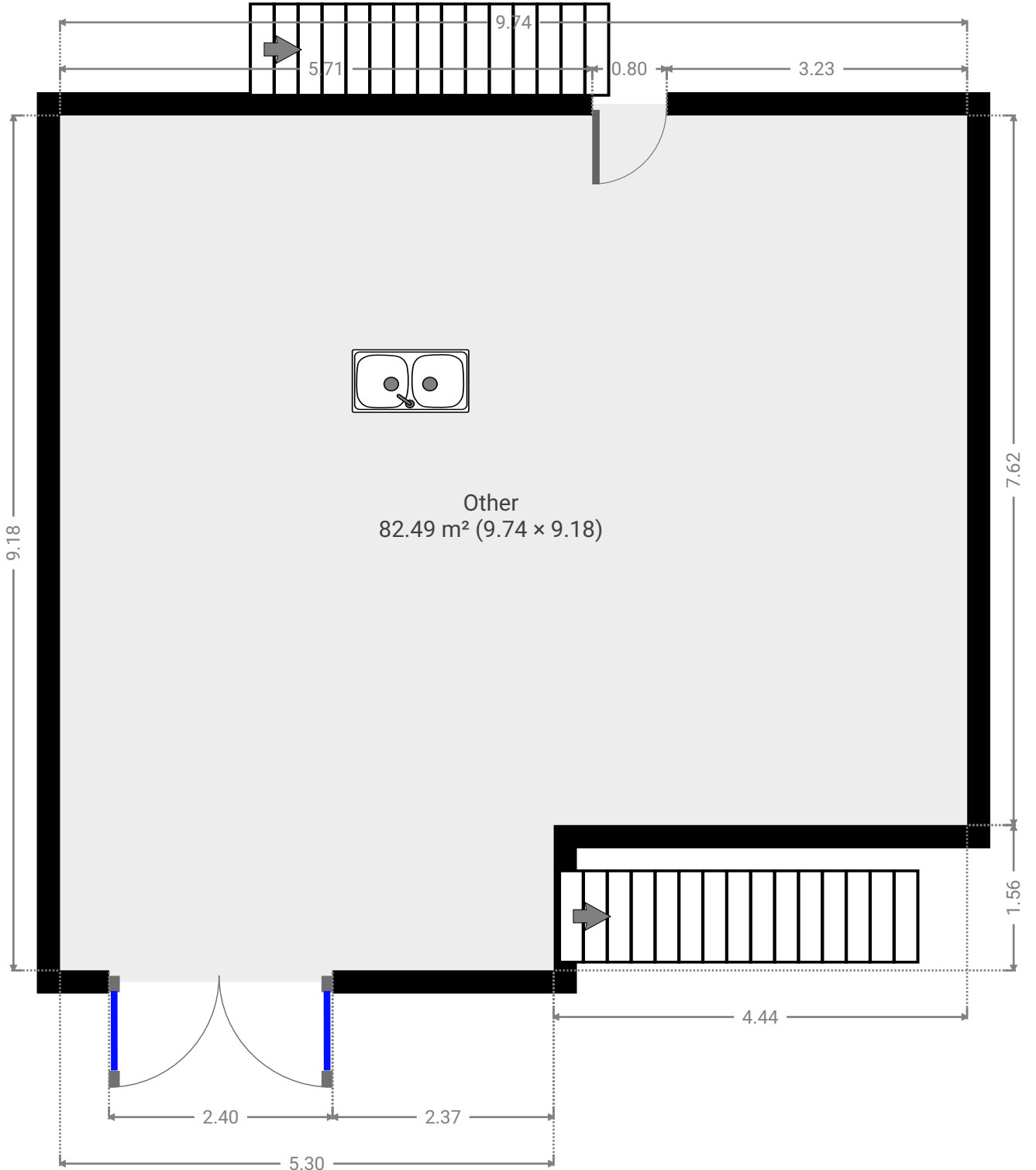

▼ Other  
Ground Floor

WIDTH: 9.74 m • LENGTH: 9.18 m  
AREA: 82.49 m<sup>2</sup> • PERIMETER: 37.84 m

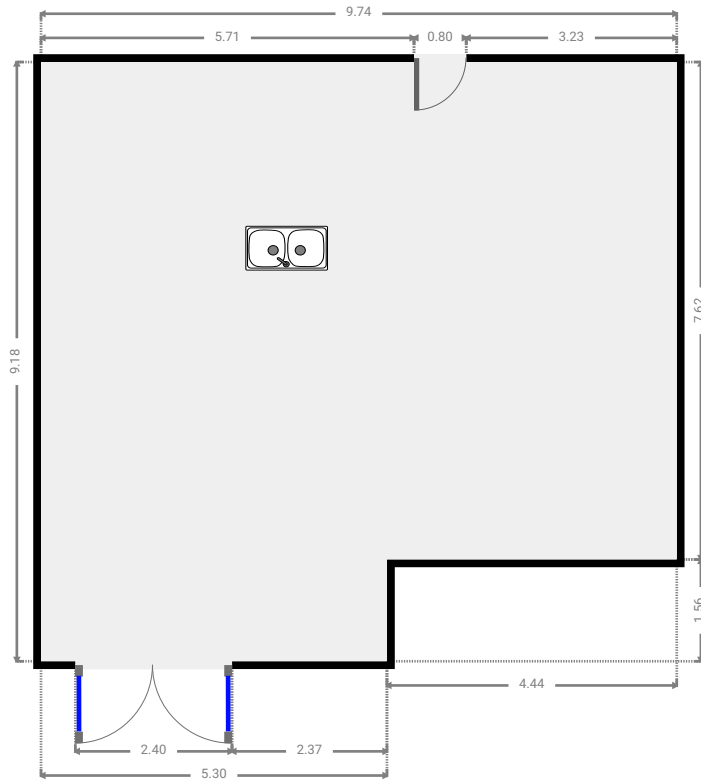
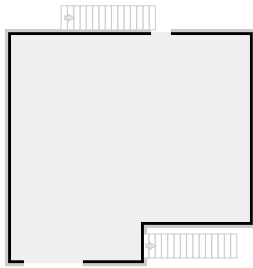

▼ 1st Floor

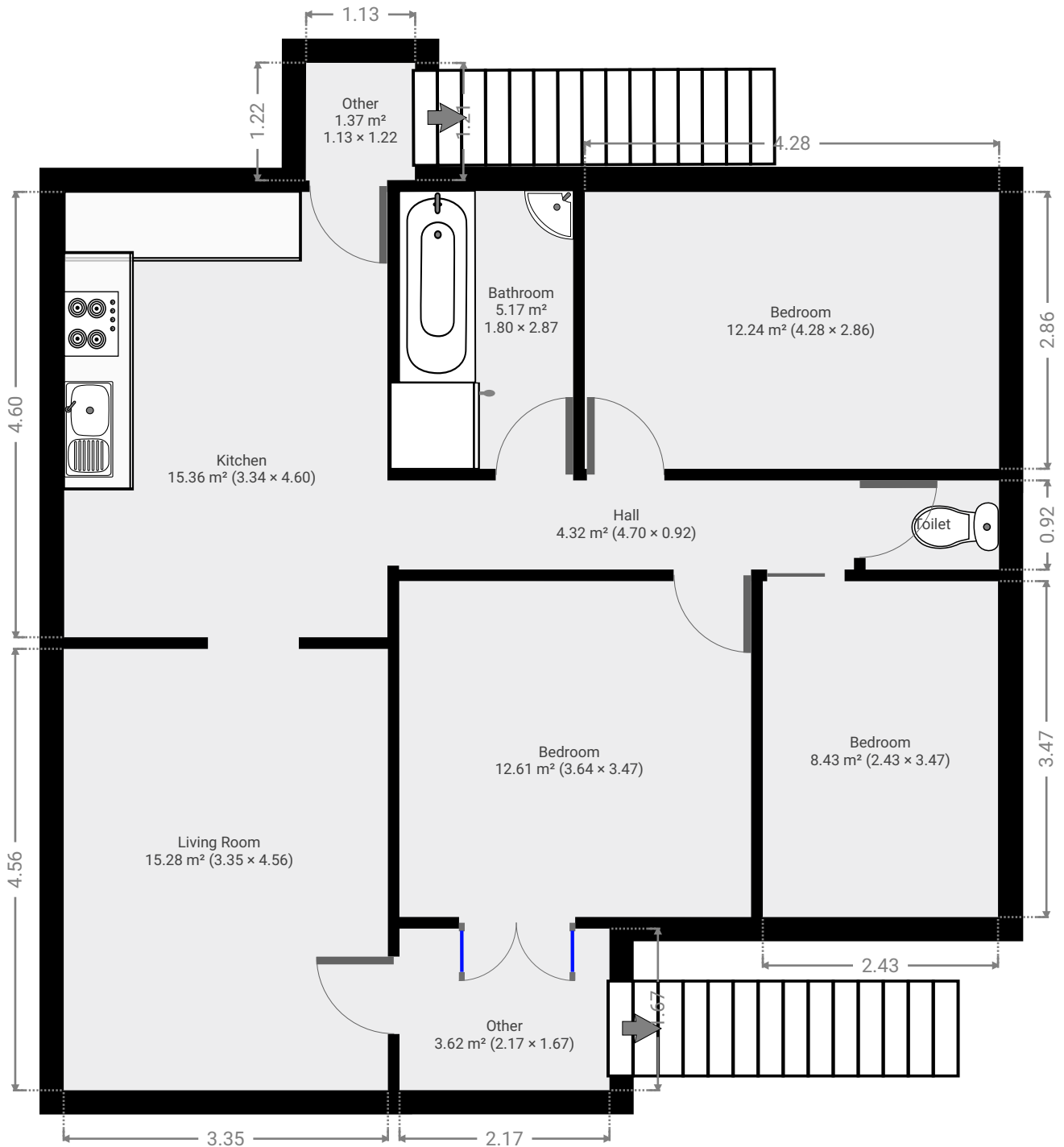

▼ **Living Room**  
1st Floor

WIDTH: 3.35 m • LENGTH: 4.56 m  
AREA: 15.28 m<sup>2</sup> • PERIMETER: 15.82 m

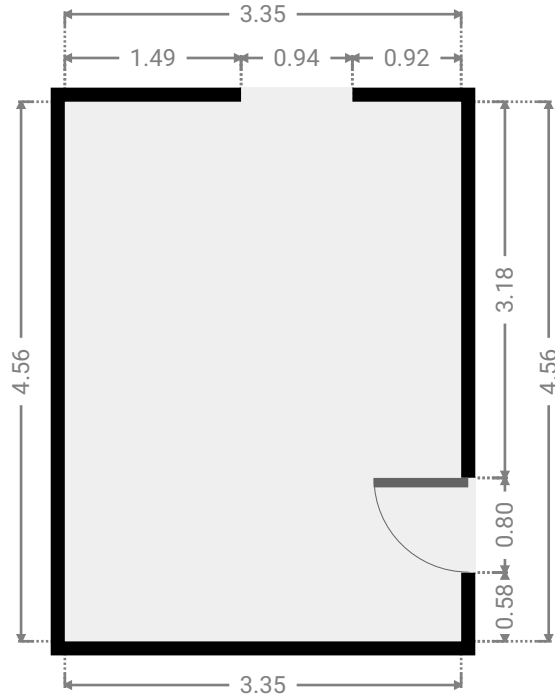
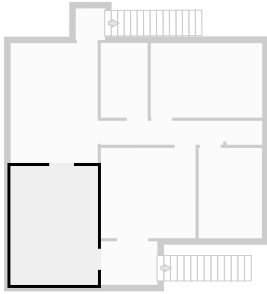

▼ **Kitchen**  
1st Floor

WIDTH: 3.34 m • LENGTH: 4.60 m  
AREA: 15.36 m<sup>2</sup> • PERIMETER: 15.88 m

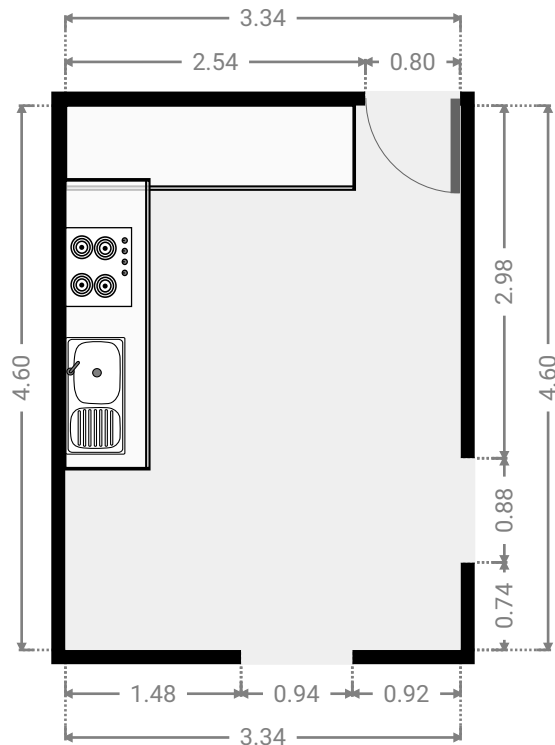
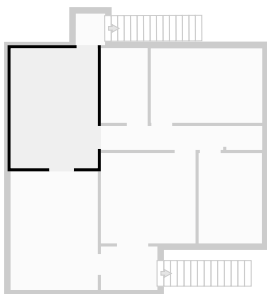

▼ **Hall**  
1st Floor

WIDTH: 4.70 m • LENGTH: 0.92 m  
AREA: 4.32 m<sup>2</sup> • PERIMETER: 11.24 m

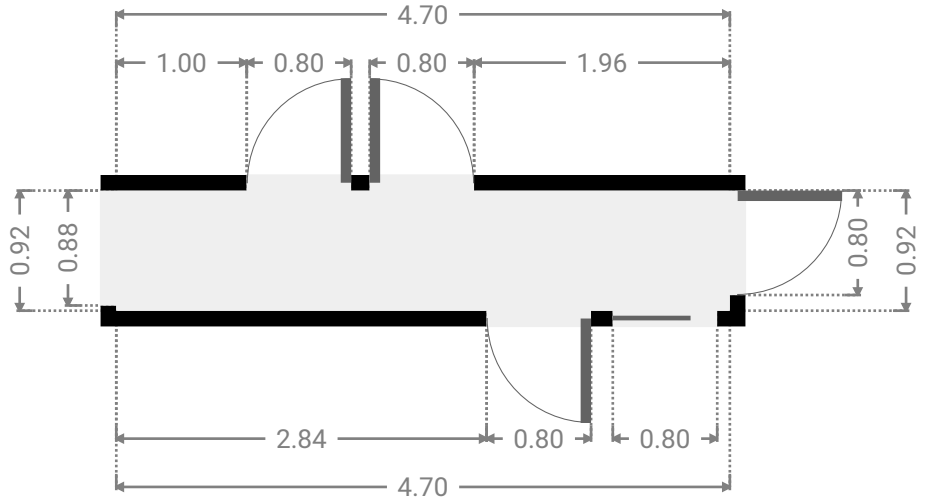
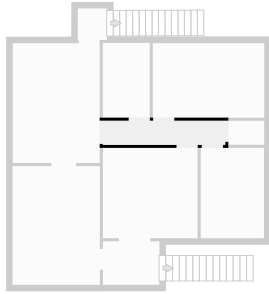

▼ **Bathroom**  
1st Floor

WIDTH: 1.80 m • LENGTH: 2.87 m  
AREA: 5.17 m<sup>2</sup> • PERIMETER: 9.34 m

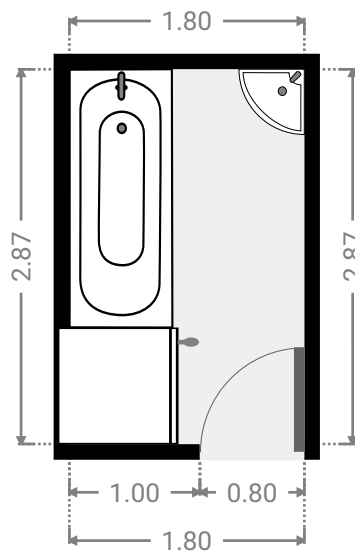
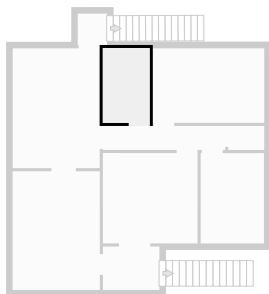

▼ **Bedroom**  
1st Floor

WIDTH: 4.28 m • LENGTH: 2.86 m  
AREA: 12.24 m<sup>2</sup> • PERIMETER: 14.28 m

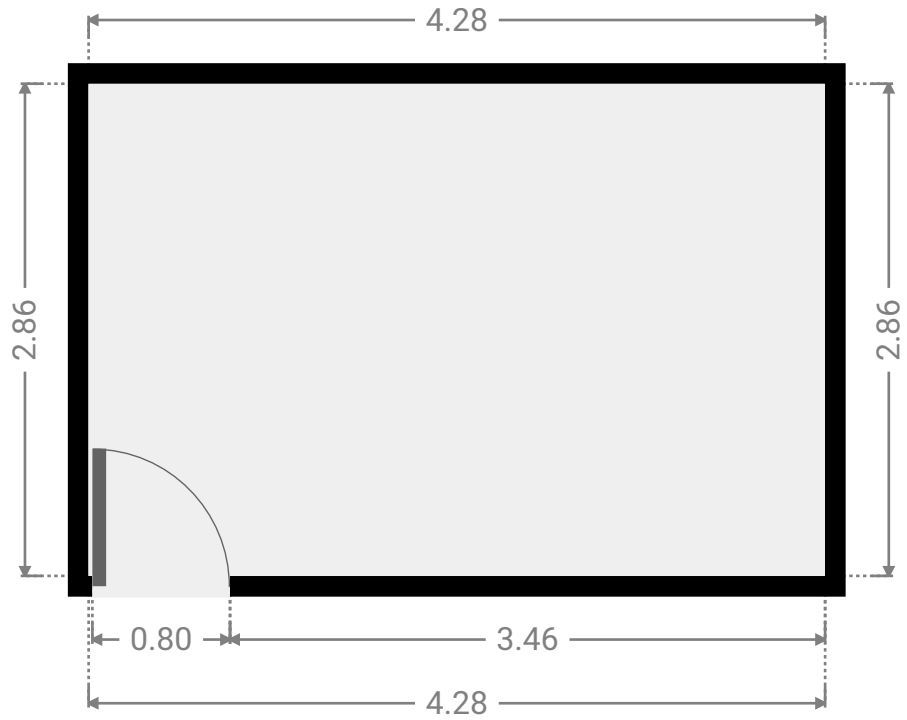
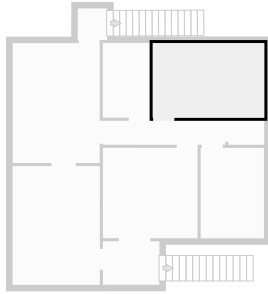

▼ **Toilet**  
1st Floor

WIDTH: 1.38 m • LENGTH: 0.92 m  
AREA: 1.27 m<sup>2</sup> • PERIMETER: 4.60 m

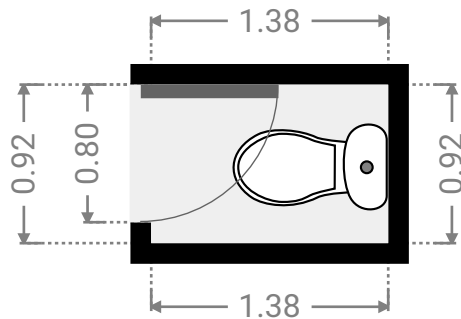
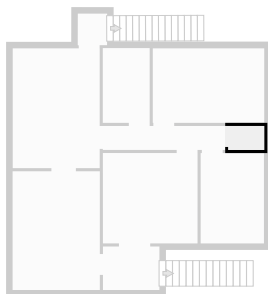

▼ **Bedroom**  
1st Floor

WIDTH: 2.43 m • LENGTH: 3.47 m  
AREA: 8.43 m<sup>2</sup> • PERIMETER: 11.80 m

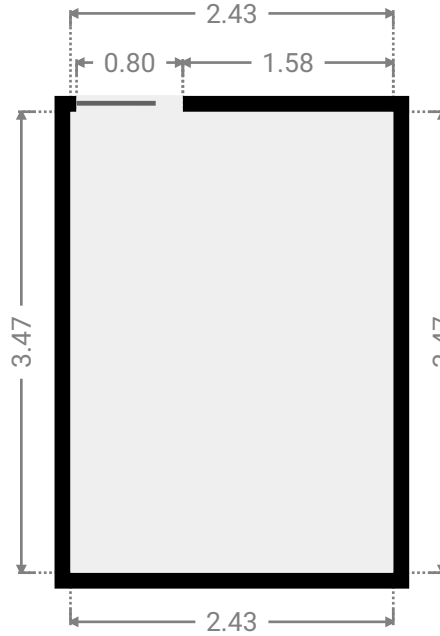
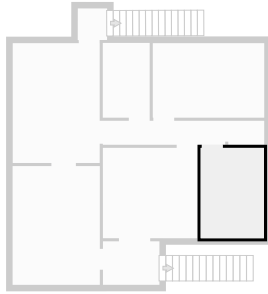

▼ **Bedroom**  
1st Floor

WIDTH: 3.64 m • LENGTH: 3.47 m  
AREA: 12.61 m<sup>2</sup> • PERIMETER: 14.21 m

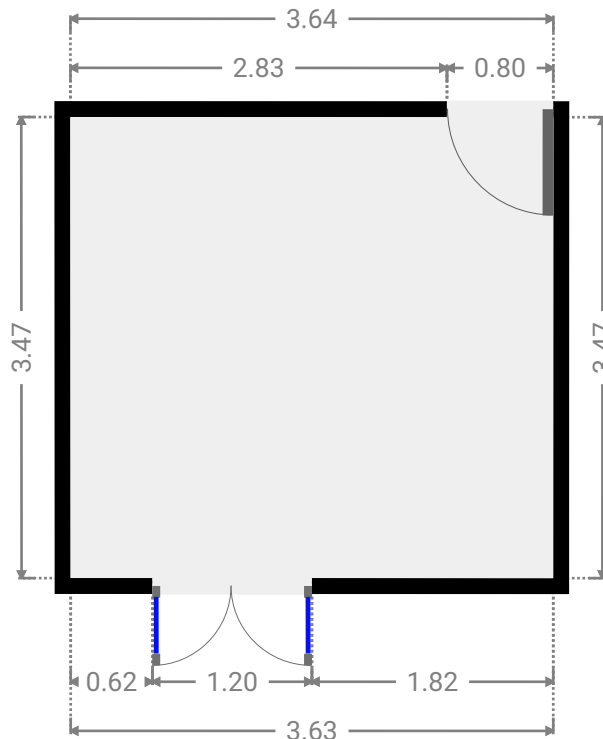
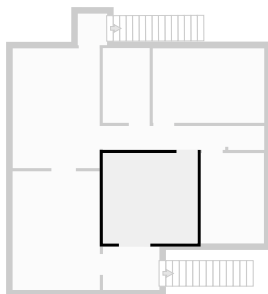



FLOORS: 2

▼ Other  
1st Floor

WIDTH: 2.17 m • LENGTH: 1.67 m  
AREA: 3.62 m<sup>2</sup> • PERIMETER: 7.68 m

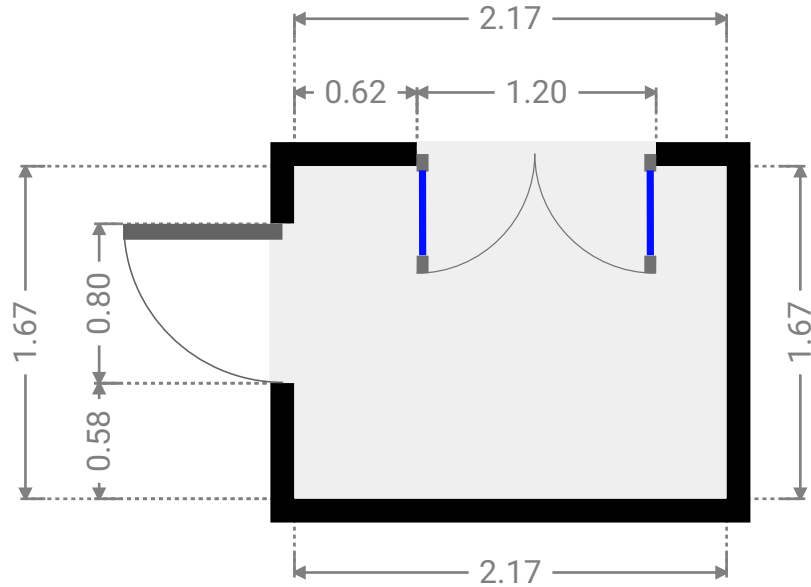
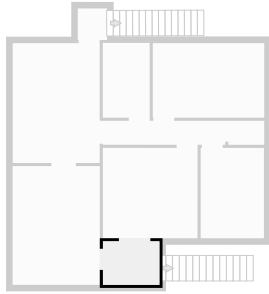

▼ Other  
1st Floor

WIDTH: 1.13 m • LENGTH: 1.22 m  
AREA: 1.37 m<sup>2</sup> • PERIMETER: 4.68 m

