

63 West Street

SUBMITTED BY
Ray White Rockhampton Casey
stockers@cqoz.com

CREATED ON
2022-07-26

Floors 1

▼ Ground Floor

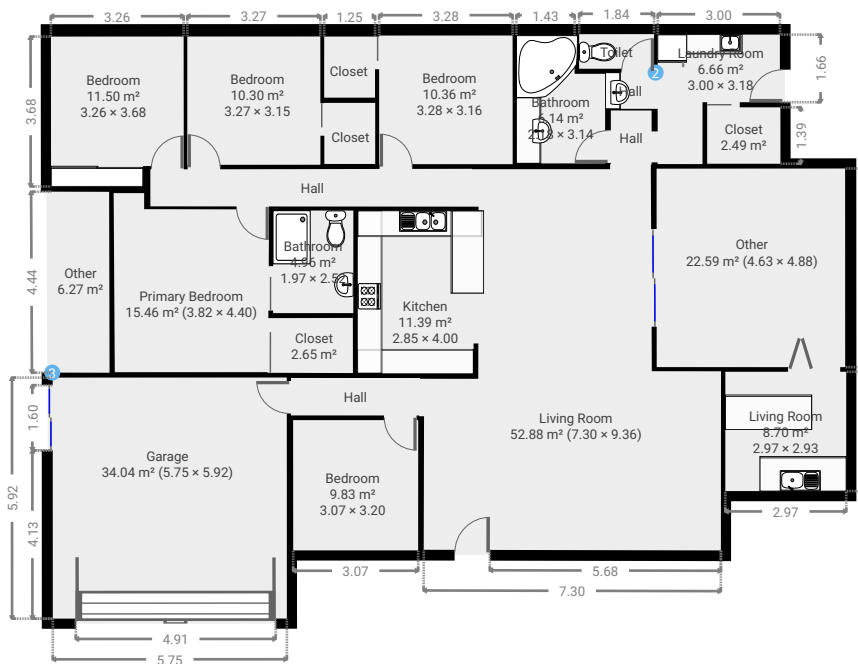
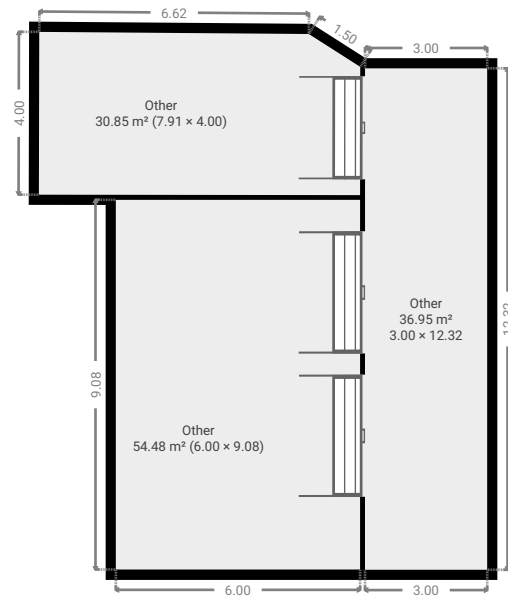
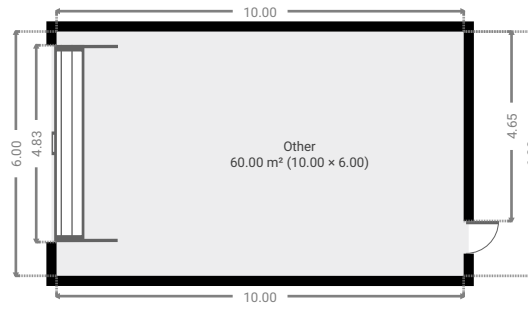

▼ **Bathroom**
Ground Floor

WIDTH: 2.18 m • LENGTH: 3.14 m
AREA: 6.14 m² • PERIMETER: 10.64 m

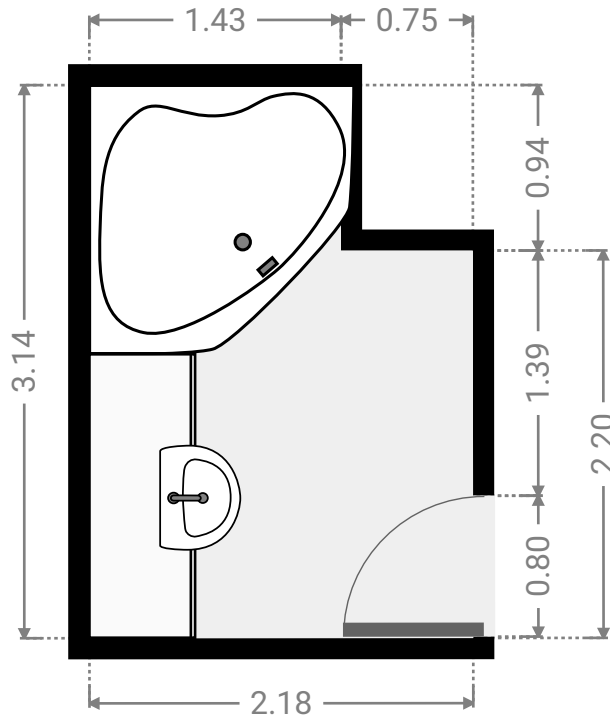
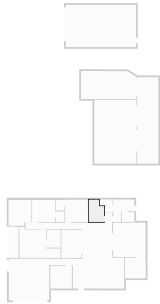

▼ **Bathroom**
Ground Floor

WIDTH: 1.97 m • LENGTH: 2.52 m
AREA: 4.96 m² • PERIMETER: 8.98 m

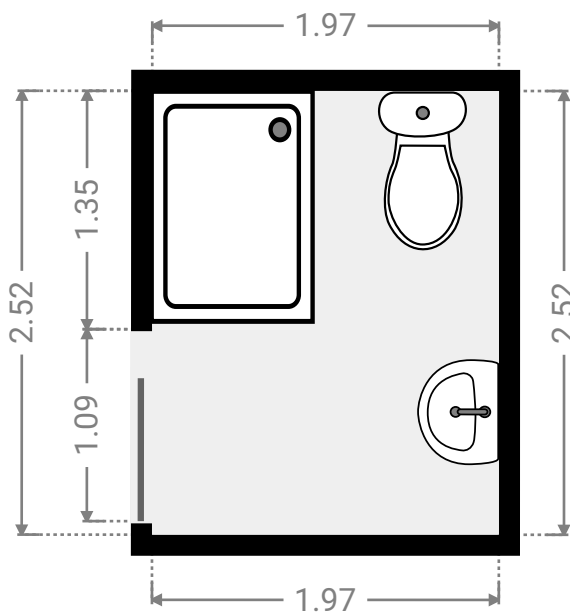
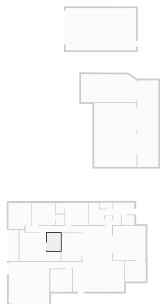

▼ **Bedroom**
Ground Floor

WIDTH: 3.07 m • LENGTH: 3.20 m
AREA: 9.83 m² • PERIMETER: 12.54 m

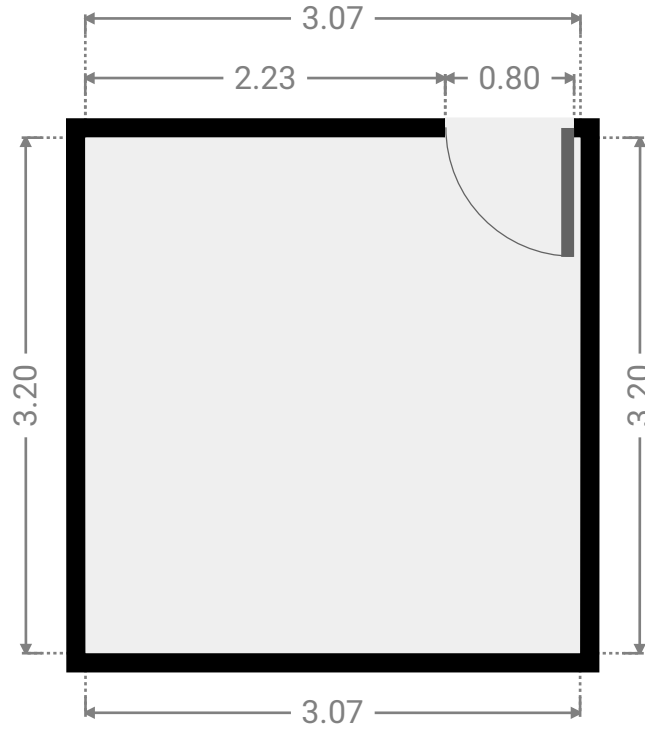
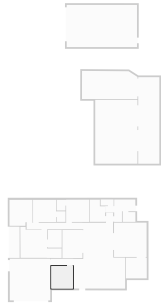

▼ **Bedroom**
Ground Floor

WIDTH: 3.28 m • LENGTH: 3.16 m
AREA: 10.36 m² • PERIMETER: 12.88 m

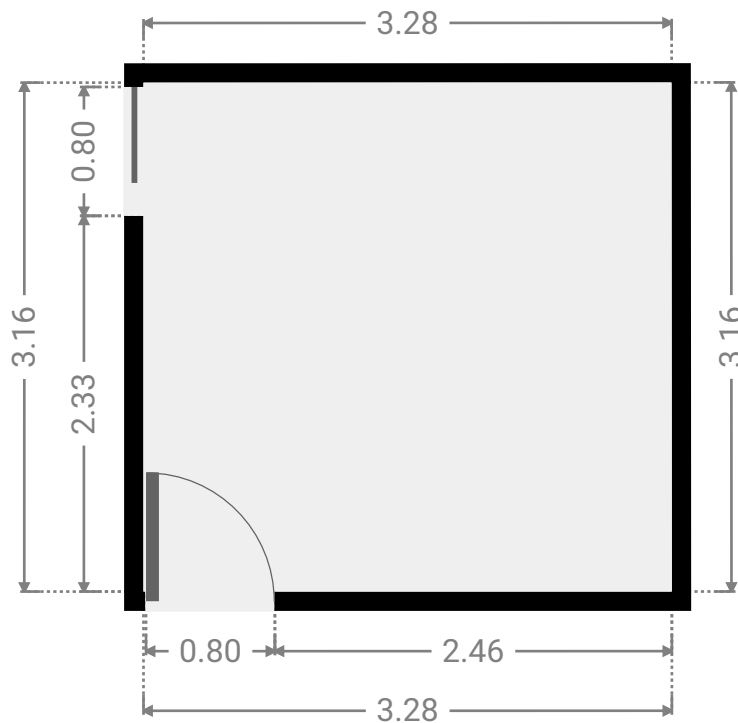
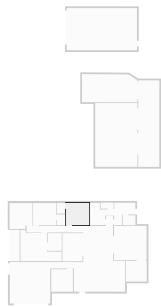

▼ **Closet**
Ground Floor

WIDTH: 1.25 m • LENGTH: 1.50 m
AREA: 1.87 m² • PERIMETER: 5.50 m

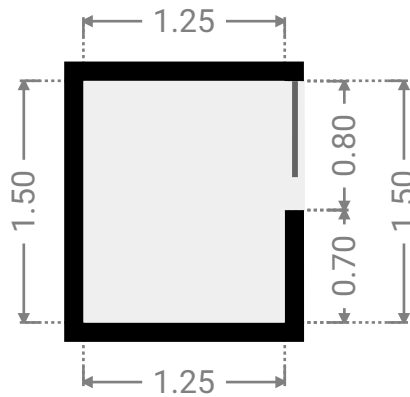

▼ **Bedroom**
Ground Floor

WIDTH: 3.27 m • LENGTH: 3.15 m
AREA: 10.30 m² • PERIMETER: 12.84 m

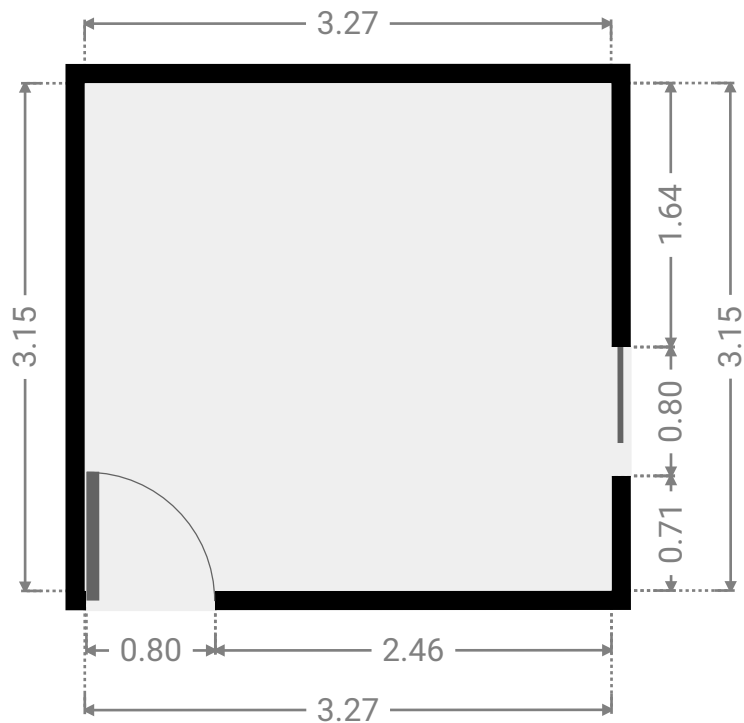
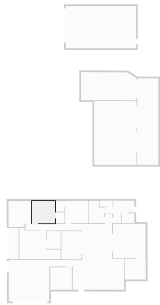

FLOORS: 1

▼ Closet
Ground Floor

WIDTH: 1.25 m • LENGTH: 1.50 m
AREA: 1.87 m² • PERIMETER: 5.50 m

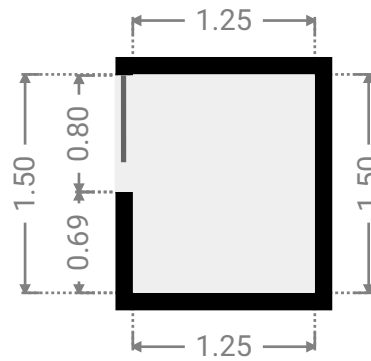
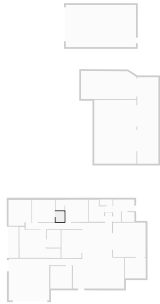

▼ Bedroom
Ground Floor

WIDTH: 3.26 m • LENGTH: 3.68 m
AREA: 11.50 m² • PERIMETER: 13.88 m

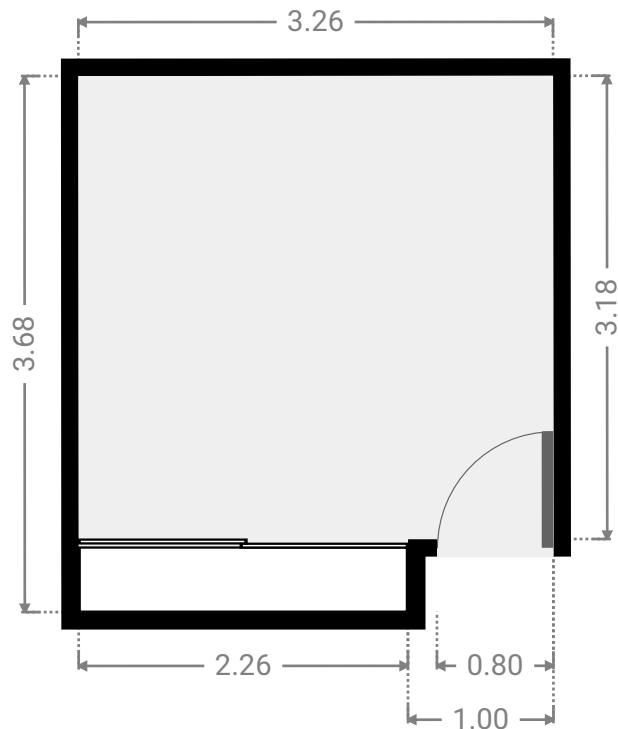
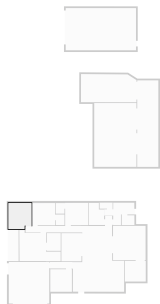

▼ **Garage**
Ground Floor

WIDTH: 5.75 m • LENGTH: 5.92 m
AREA: 34.04 m² • PERIMETER: 23.34 m

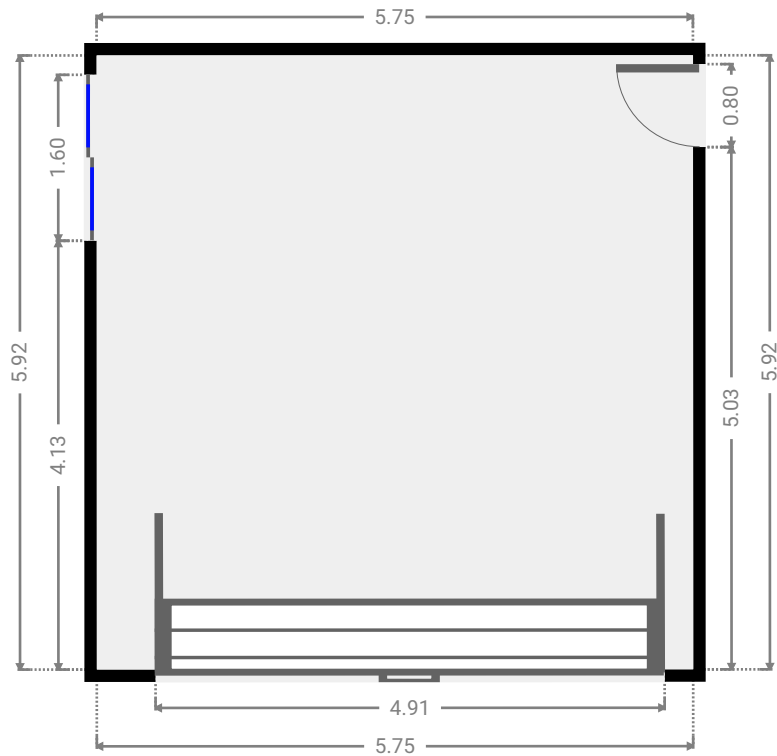
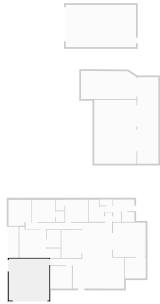

▼ **Hall**
Ground Floor

WIDTH: 3.17 m • LENGTH: 0.92 m
AREA: 2.92 m² • PERIMETER: 8.18 m

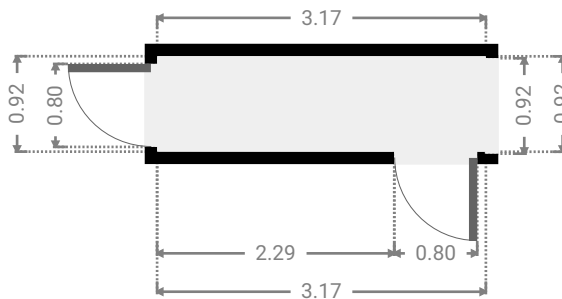
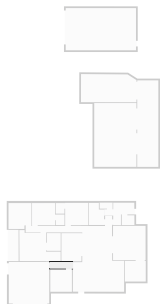

▼ Hall
Ground Floor

WIDTH: 7.90 m • LENGTH: 0.93 m
AREA: 7.25 m² • PERIMETER: 17.64 m

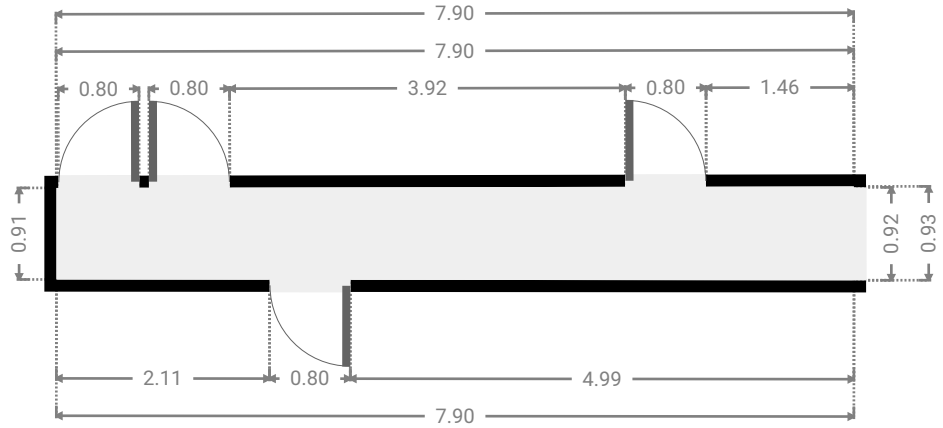
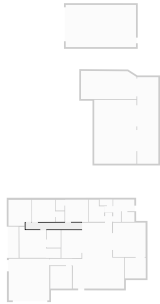

▼ Hall
Ground Floor

WIDTH: 1.00 m • LENGTH: 1.33 m
AREA: 1.33 m² • PERIMETER: 4.66 m

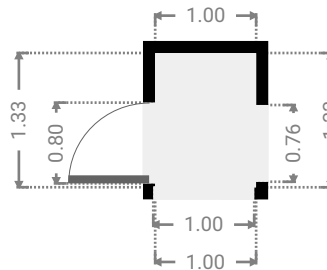
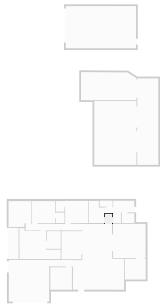

▼ **Hall**
Ground Floor

WIDTH: 1.23 m • LENGTH: 0.89 m
AREA: 1.09 m² • PERIMETER: 4.24 m

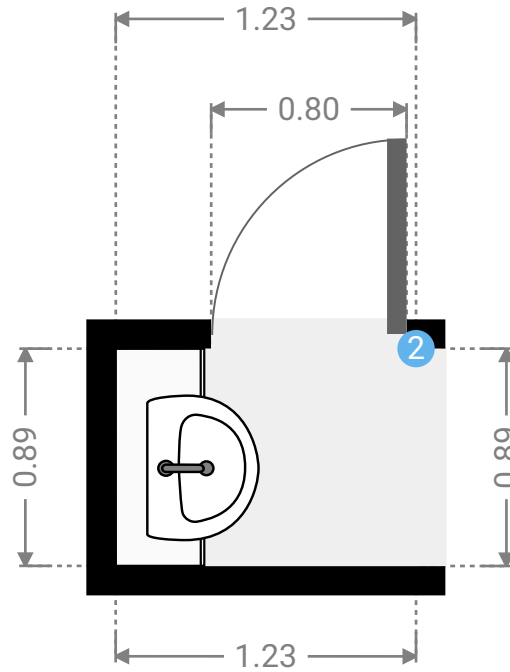

▼ **Hall/Ground Floor**

2 OPENING

Height
0.00 m



▼ Kitchen
Ground Floor

WIDTH: 2.85 m • LENGTH: 4.00 m
AREA: 11.39 m² • PERIMETER: 13.70 m

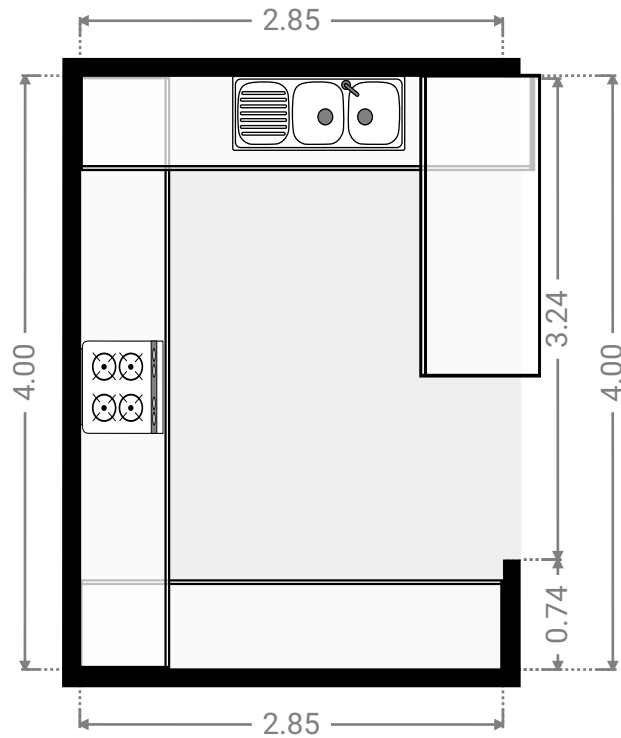
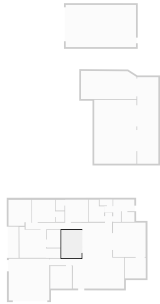

▼ Laundry Room
Ground Floor

WIDTH: 3.00 m • LENGTH: 3.18 m
AREA: 6.66 m² • PERIMETER: 12.36 m

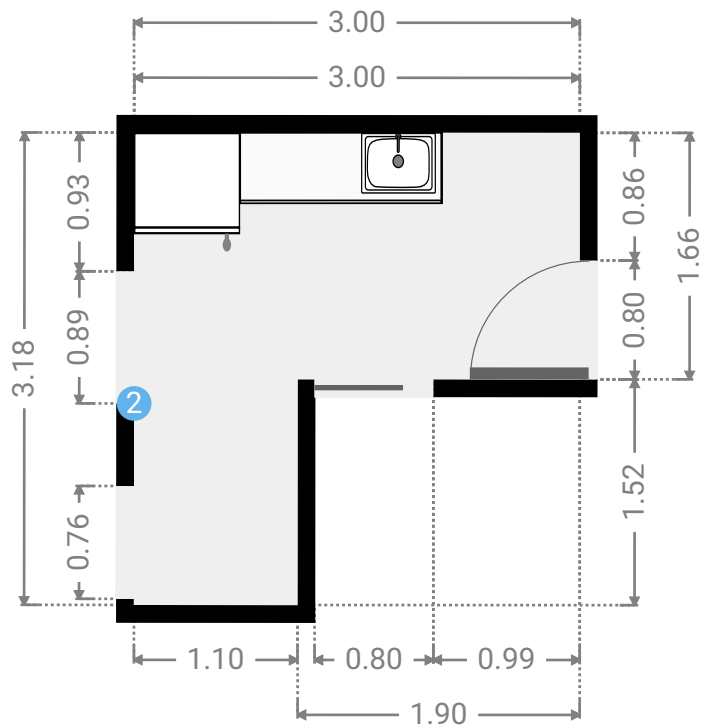

▼ **Closet**
Ground Floor

WIDTH: 1.80 m • LENGTH: 1.39 m
AREA: 2.49 m² • PERIMETER: 6.37 m

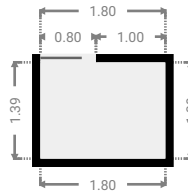
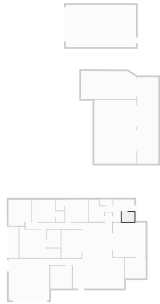

▼ **Living Room**
Ground Floor

WIDTH: 7.30 m • LENGTH: 9.36 m
AREA: 52.88 m² • PERIMETER: 33.27 m

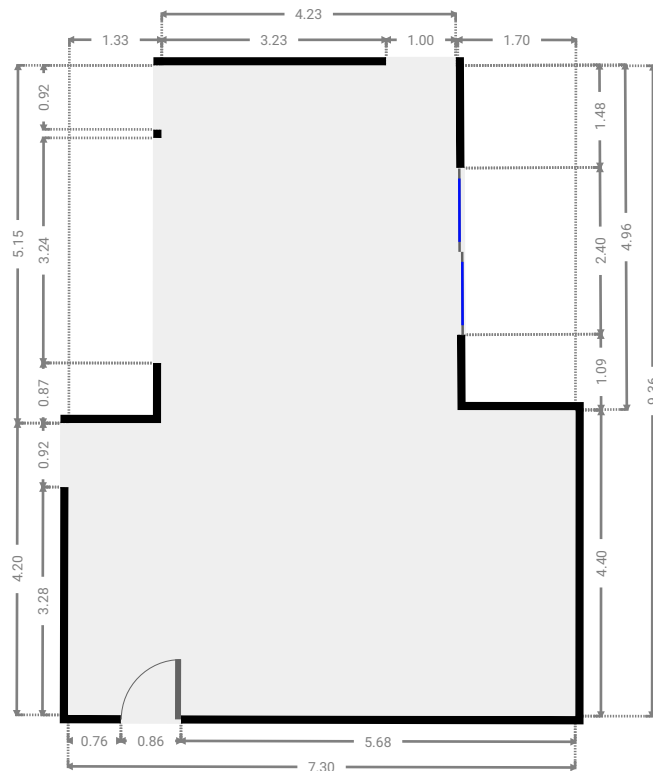
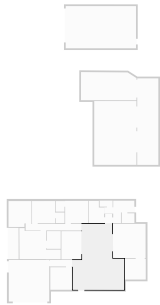

▼ **Living Room**
Ground Floor

WIDTH: 2.97 m • LENGTH: 2.93 m
AREA: 8.70 m² • PERIMETER: 11.80 m

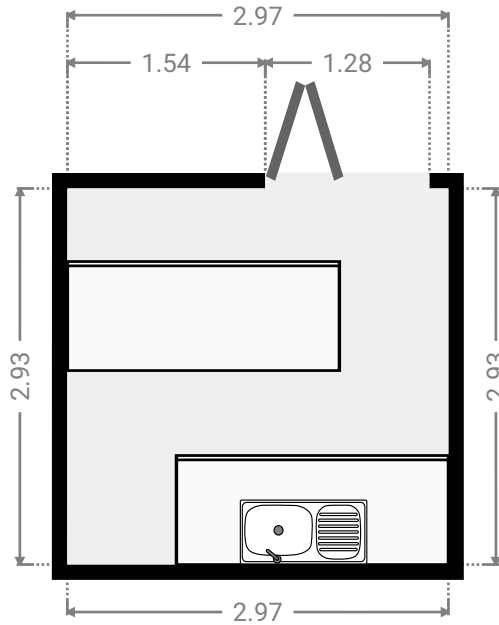
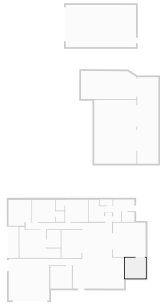

▼ **Other**
Ground Floor

WIDTH: 1.44 m • LENGTH: 4.44 m
AREA: 6.27 m² • PERIMETER: 11.71 m

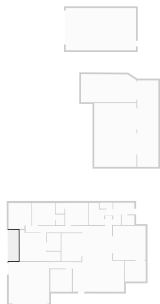

▼ **Other**/Ground Floor

3 **OPENING**

Height
0.00 m



FLOORS: 1

▼ Other
Ground Floor

WIDTH: 4.63 m • LENGTH: 4.88 m
AREA: 22.59 m² • PERIMETER: 19.02 m

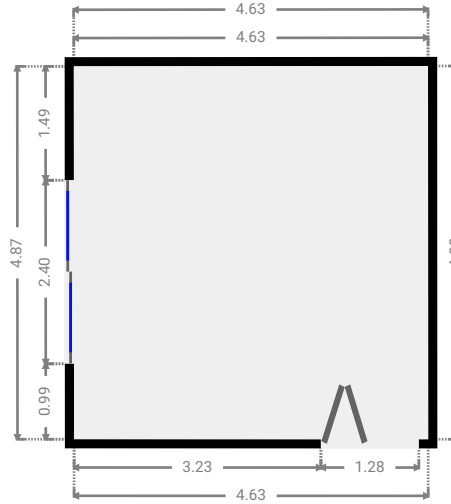
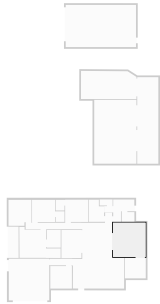

▼ Other
Ground Floor

WIDTH: 6.00 m • LENGTH: 9.08 m
AREA: 54.48 m² • PERIMETER: 30.16 m

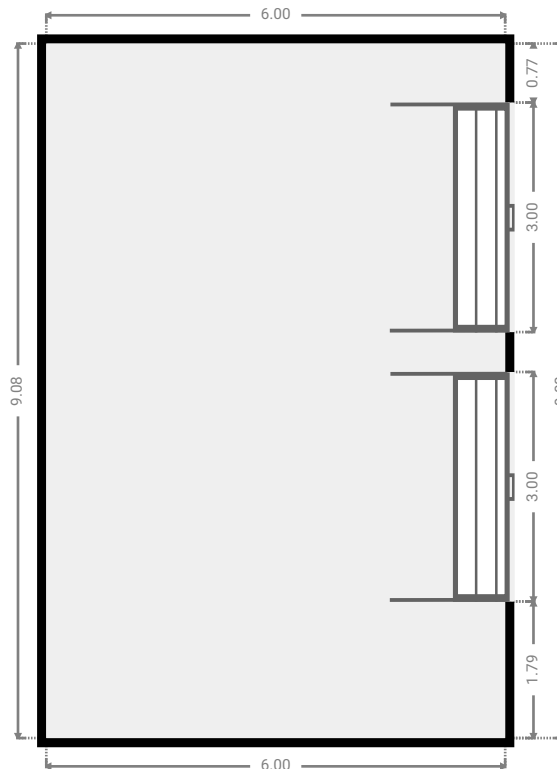
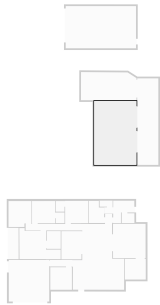

▼ Other
Ground Floor

WIDTH: 7.91 m • LENGTH: 4.00 m
AREA: 30.85 m² • PERIMETER: 23.16 m

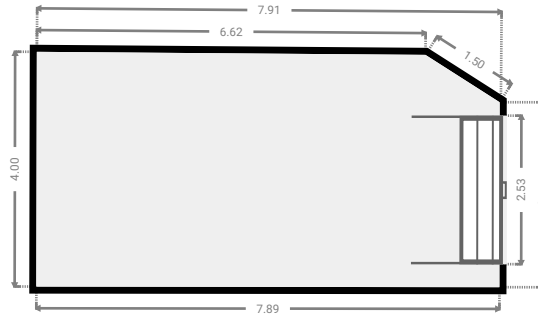
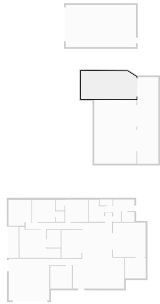

▼ Other
Ground Floor

WIDTH: 3.00 m • LENGTH: 12.32 m
AREA: 36.95 m² • PERIMETER: 30.63 m

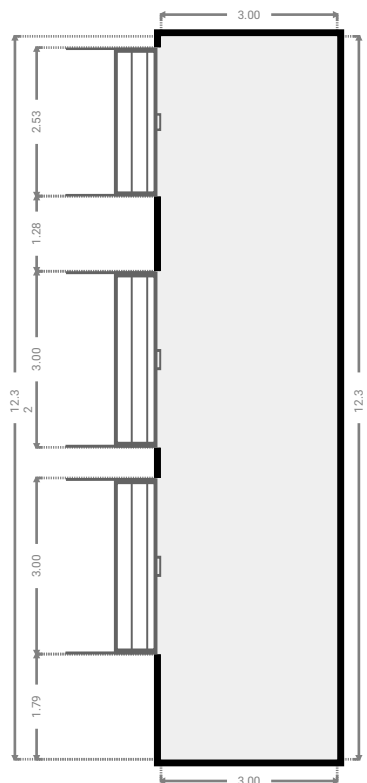
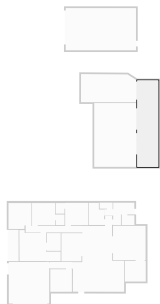

▼ Other
Ground Floor

WIDTH: 10.00 m • LENGTH: 6.00 m
AREA: 60.00 m² • PERIMETER: 32.00 m

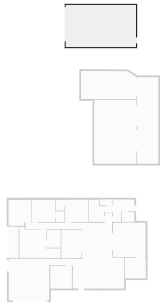

▼ Primary Bedroom
Ground Floor

WIDTH: 3.82 m • LENGTH: 4.40 m
AREA: 15.46 m² • PERIMETER: 16.37 m

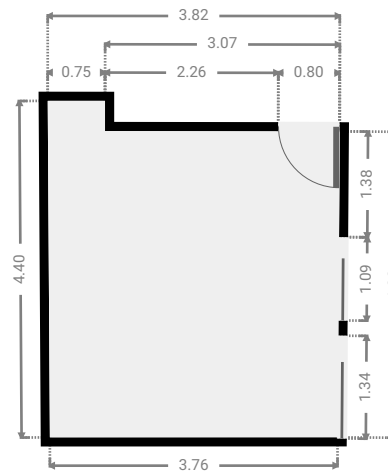
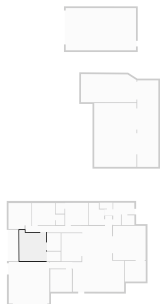

▼ **Closet**
Ground Floor

WIDTH: 1.96 m • LENGTH: 1.36 m
AREA: 2.65 m² • PERIMETER: 6.62 m

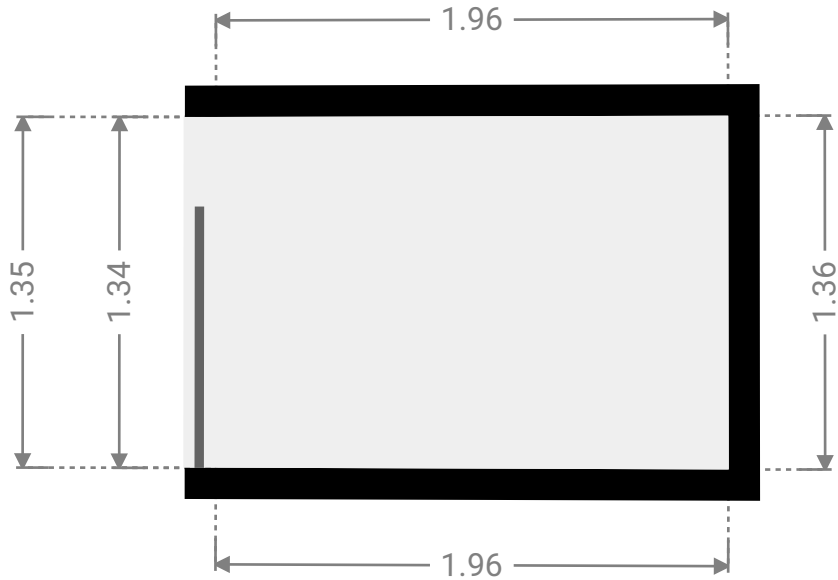
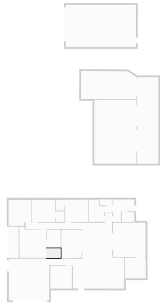

▼ **Toilet**
Ground Floor

WIDTH: 1.84 m • LENGTH: 0.85 m
AREA: 1.56 m² • PERIMETER: 5.38 m

