

62 Rice Street

SUBMITTED BY

Ray White Rockhampton Casey
stockers@cqoz.com

CREATED ON

2022-11-07

Floors

2

▼ Ground Floor

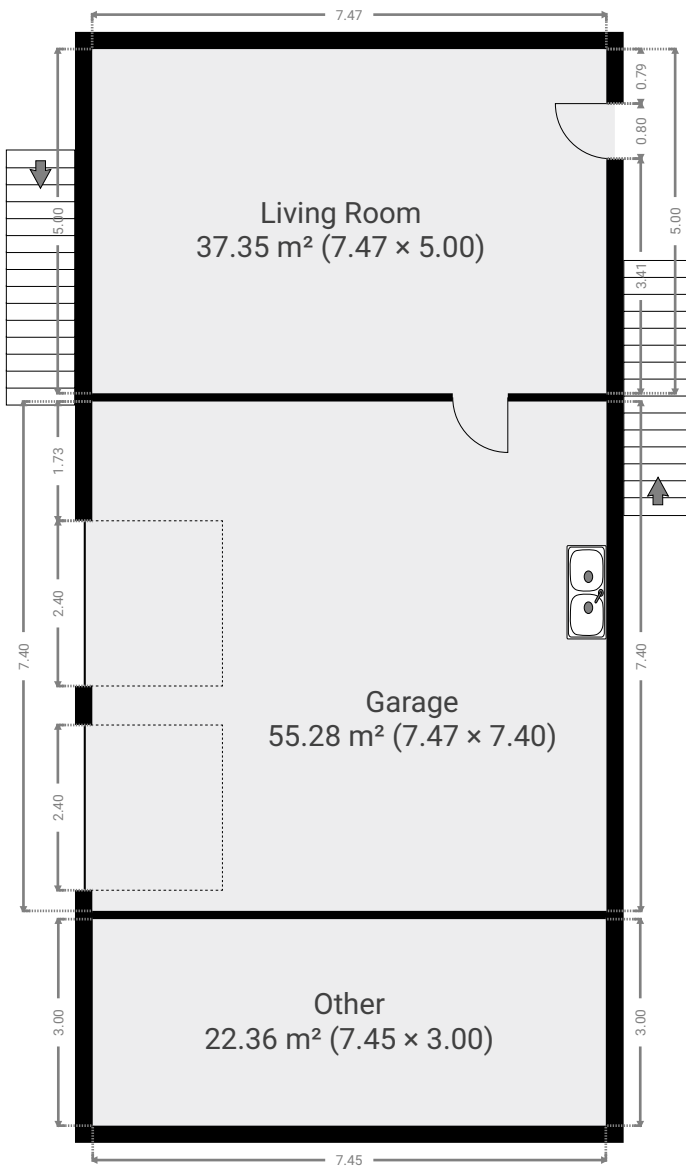
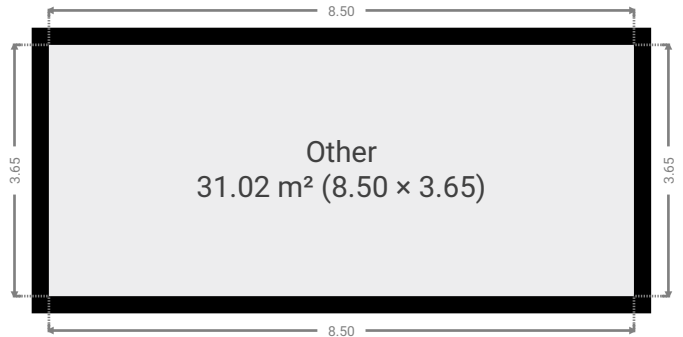

▼ **Garage**
Ground Floor

WIDTH: 7.40 m • LENGTH: 7.47 m
AREA: 55.28 m² • PERIMETER: 29.74 m

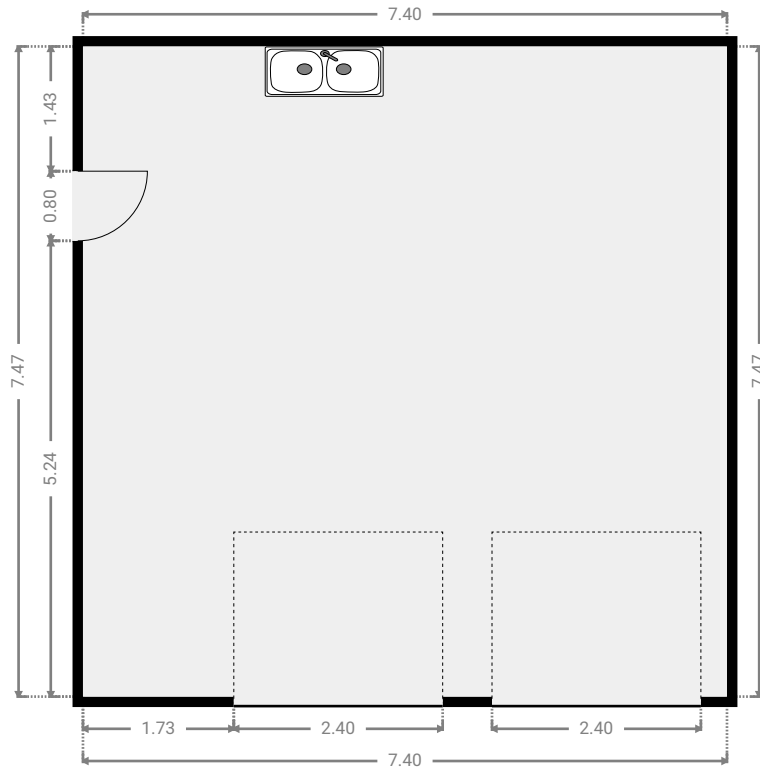
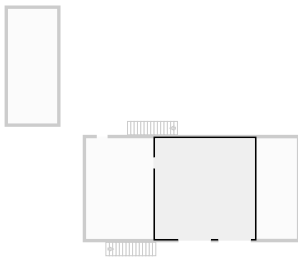

▼ **Living Room**
Ground Floor

WIDTH: 5.00 m • LENGTH: 7.47 m
AREA: 37.35 m² • PERIMETER: 24.94 m

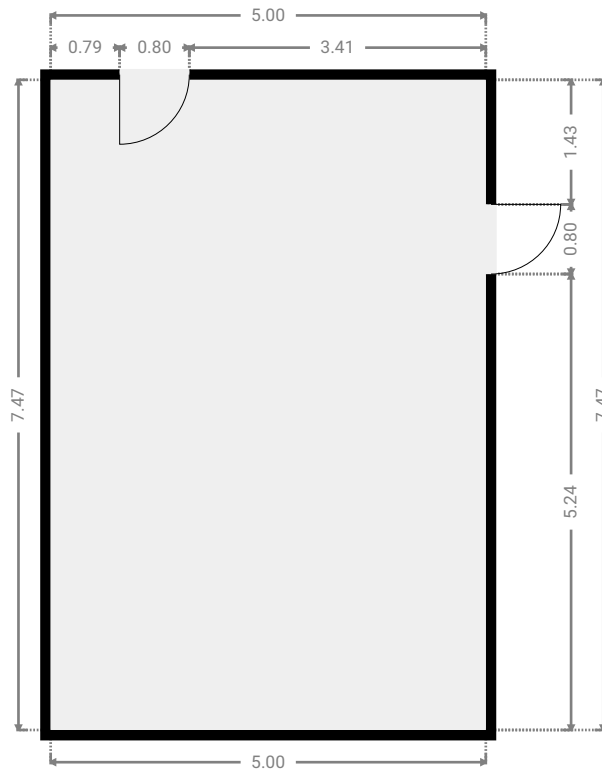
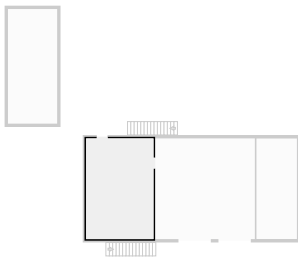

▼ Other
Ground Floor

WIDTH: 3.65 m • LENGTH: 8.50 m
AREA: 31.02 m² • PERIMETER: 24.30 m

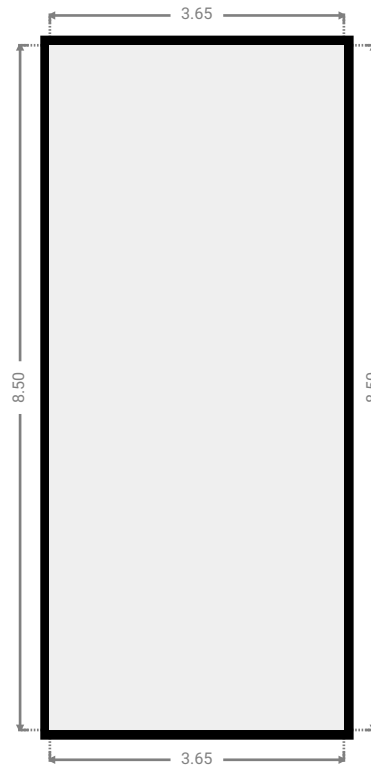
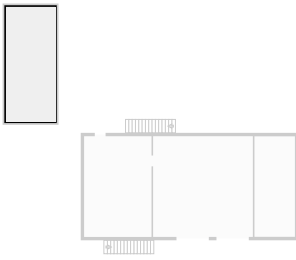

▼ Other
Ground Floor

WIDTH: 3.00 m • LENGTH: 7.45 m
AREA: 22.36 m² • PERIMETER: 20.91 m

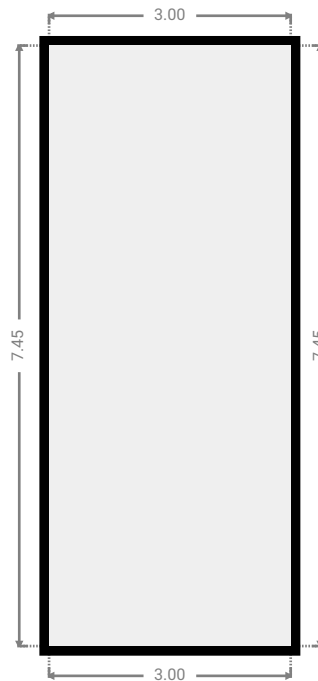
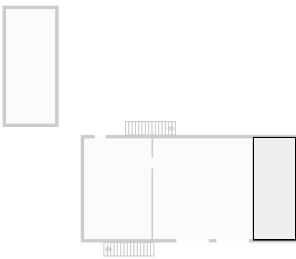

▼ 1st Floor

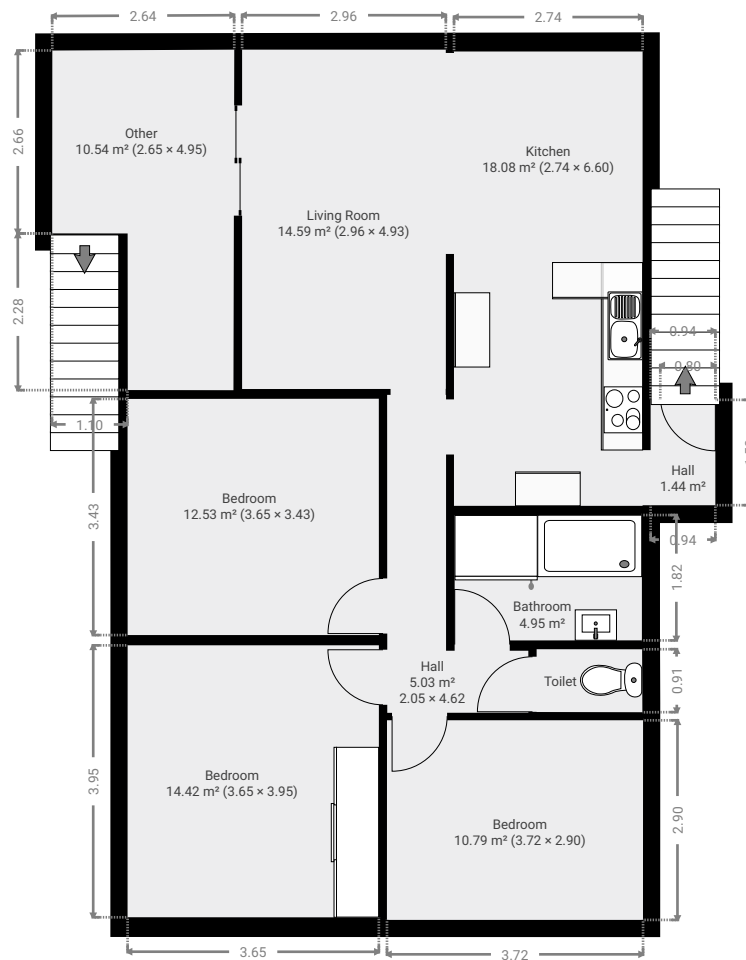

▼ **Bathroom**
1st Floor

WIDTH: 1.82 m • LENGTH: 2.72 m
AREA: 4.95 m² • PERIMETER: 9.08 m

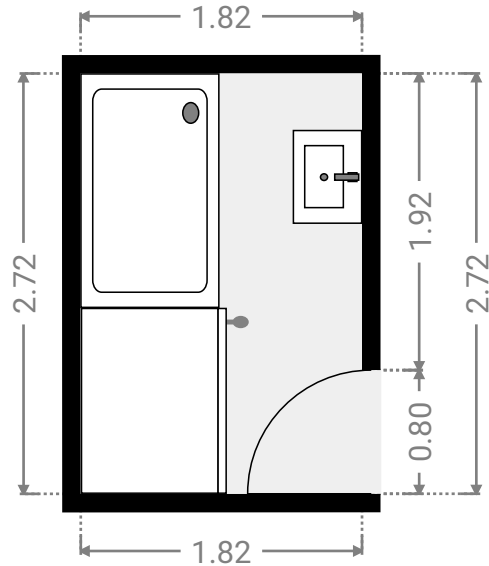
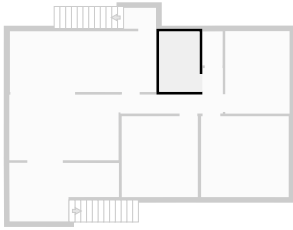

▼ **Bedroom**
1st Floor

WIDTH: 2.90 m • LENGTH: 3.72 m
AREA: 10.79 m² • PERIMETER: 13.24 m

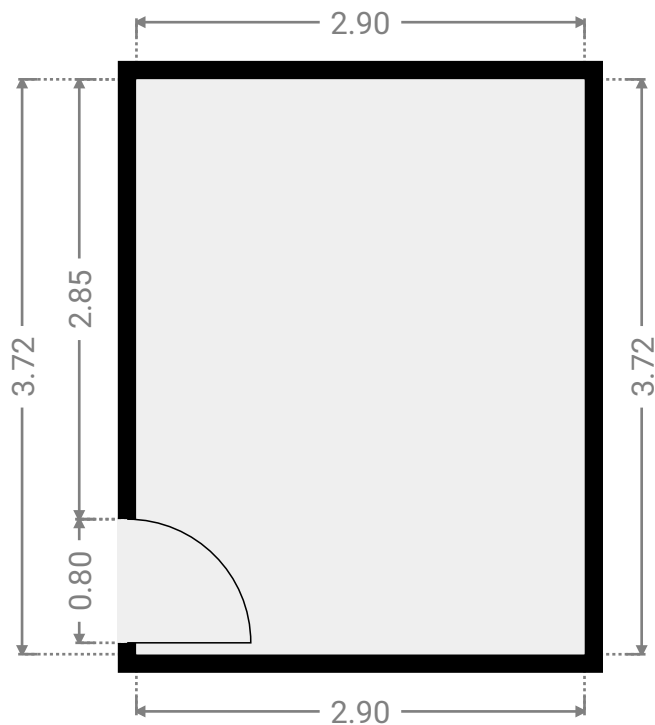
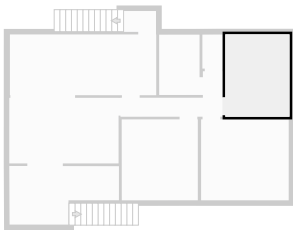

▼ **Bedroom**
1st Floor

WIDTH: 3.95 m • LENGTH: 3.65 m
AREA: 14.42 m² • PERIMETER: 15.20 m

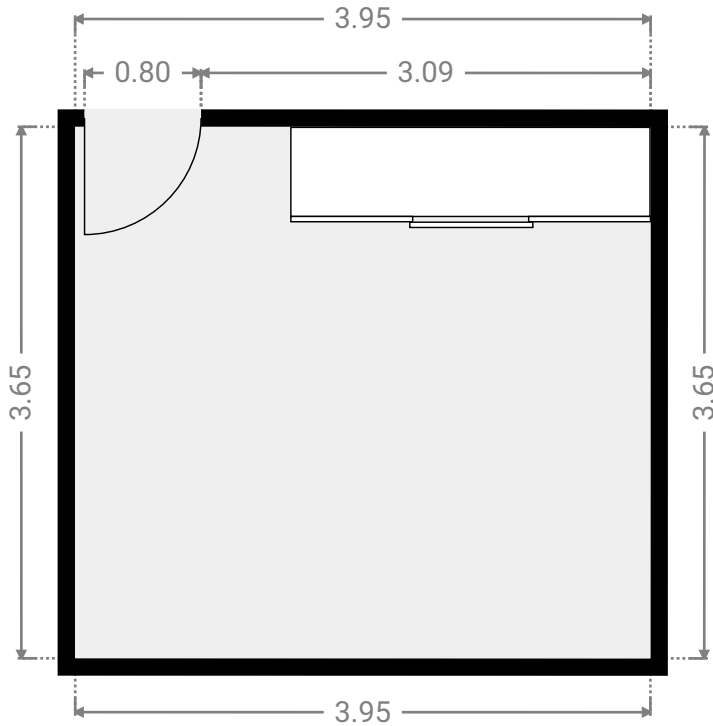
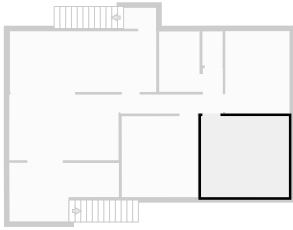

▼ **Bedroom**
1st Floor

WIDTH: 3.43 m • LENGTH: 3.65 m
AREA: 12.53 m² • PERIMETER: 14.16 m

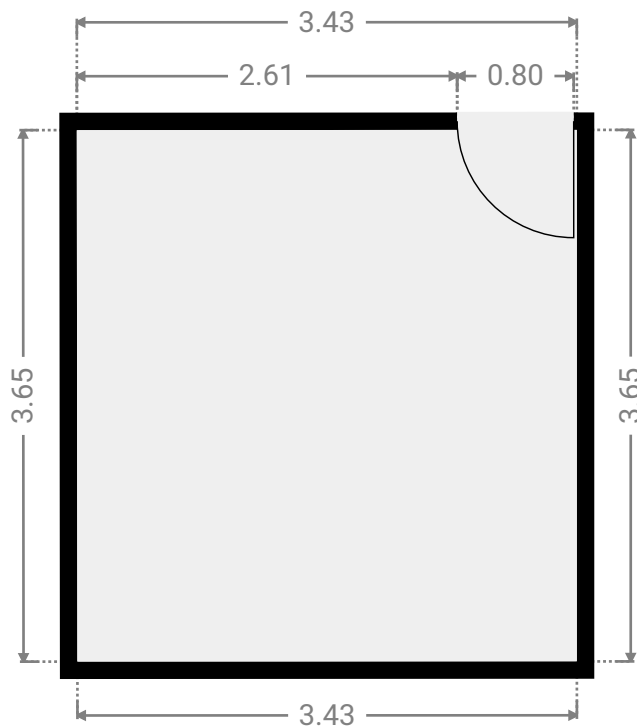
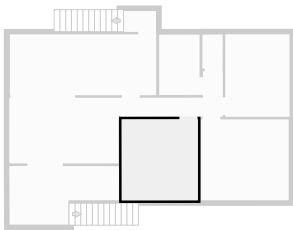

▼ **Hall**
1st Floor

WIDTH: 1.53 m • LENGTH: 0.94 m
AREA: 1.44 m² • PERIMETER: 4.94 m

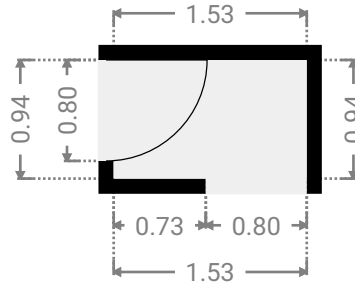
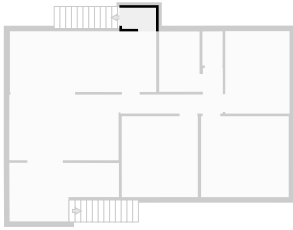

▼ **Hall**
1st Floor

WIDTH: 4.62 m • LENGTH: 2.05 m
AREA: 5.03 m² • PERIMETER: 13.34 m

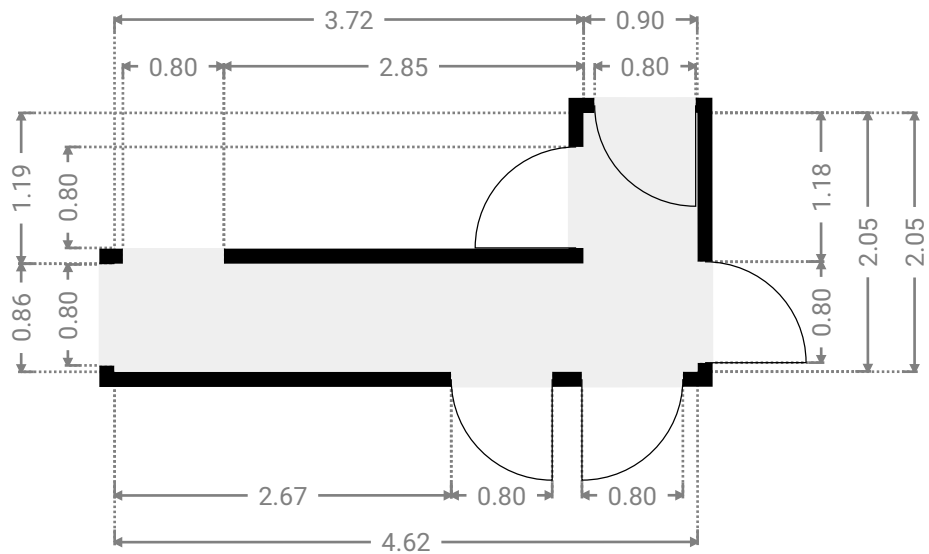
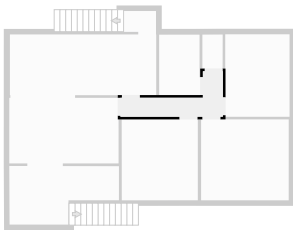

▼ **Kitchen**
1st Floor

WIDTH: 6.60 m • LENGTH: 2.74 m
AREA: 18.08 m² • PERIMETER: 18.68 m

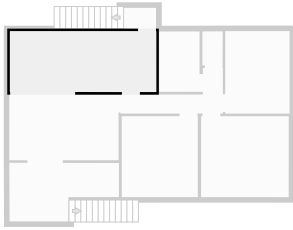

▼ **Living Room**
1st Floor

WIDTH: 4.93 m • LENGTH: 2.96 m
AREA: 14.59 m² • PERIMETER: 15.78 m

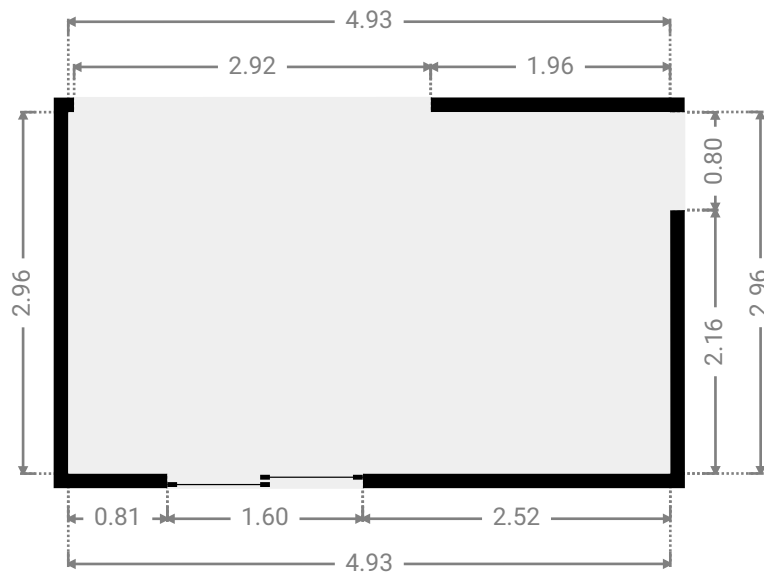
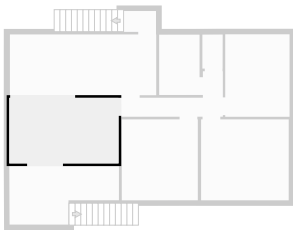

▼ **Other**
1st Floor

WIDTH: 4.95 m • LENGTH: 2.65 m
AREA: 10.54 m² • PERIMETER: 15.15 m

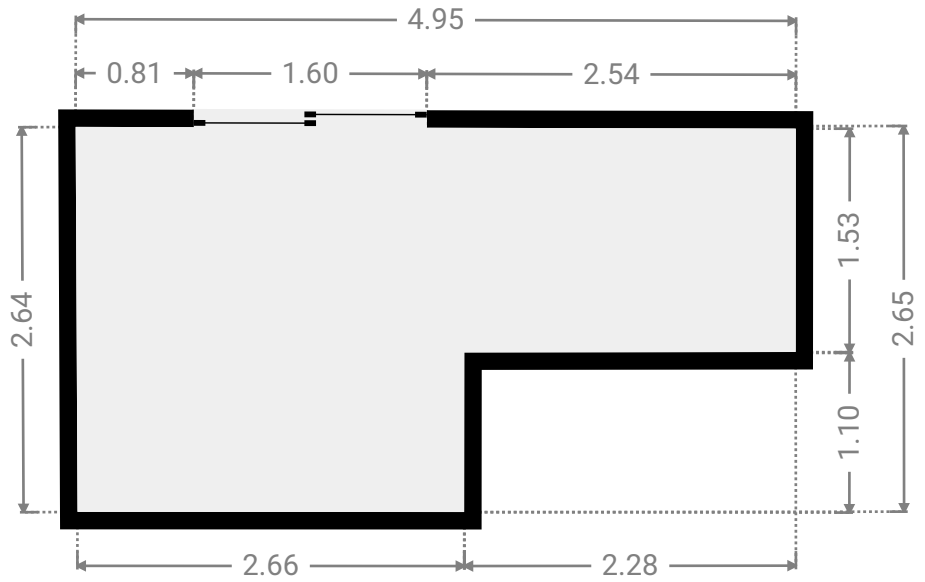
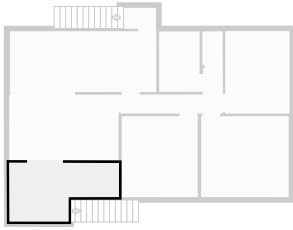

▼ **Toilet**
1st Floor

WIDTH: 0.91 m • LENGTH: 1.54 m
AREA: 1.40 m² • PERIMETER: 4.89 m

