

62 Park Street

Created on
2017-05-29

Floors
1

▼ Ground Floor

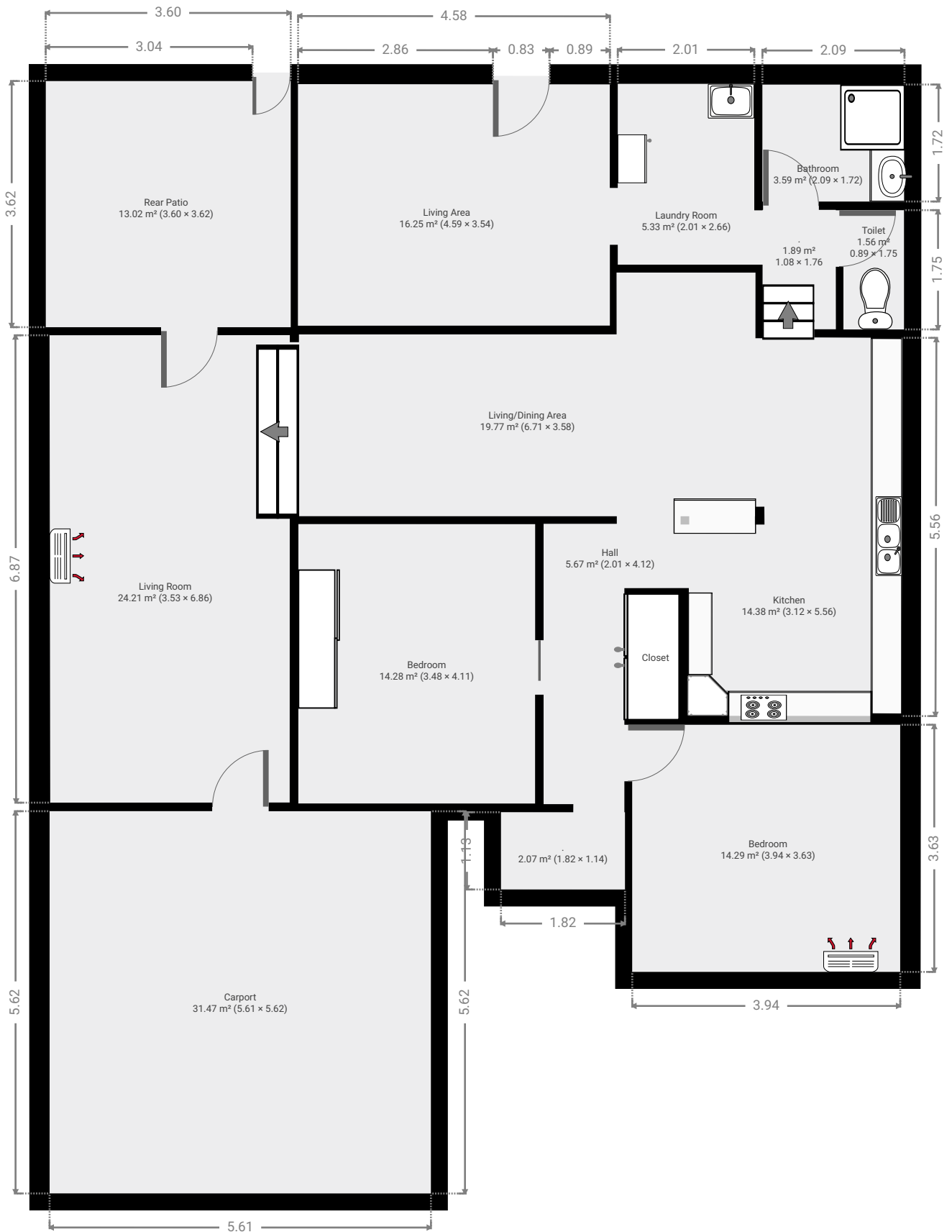

▼ Living Room
Ground Floor

WIDTH: 3.53 m • LENGTH: 6.86 m
AREA: 24.21 m² • PERIMETER: 20.78 m

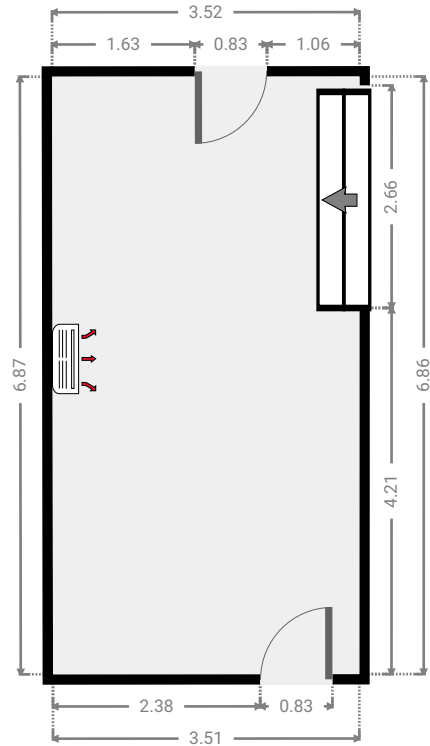
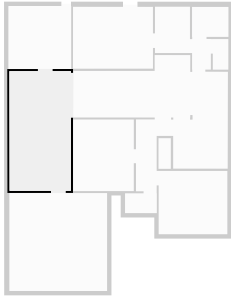

▼ Living/Dining Area
Ground Floor

WIDTH: 6.71 m • LENGTH: 3.58 m
AREA: 19.77 m² • PERIMETER: 20.57 m

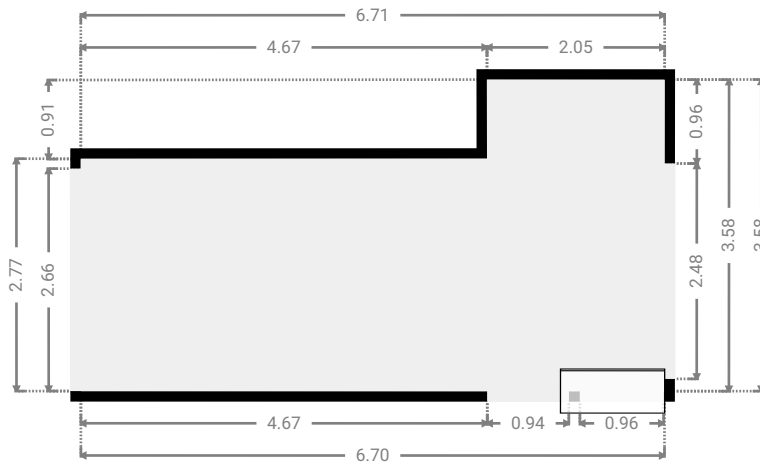
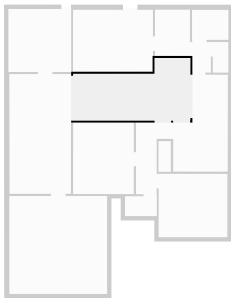

▼ Kitchen
Ground Floor

WIDTH: 3.12 m • LENGTH: 5.56 m
AREA: 14.38 m² • PERIMETER: 17.40 m

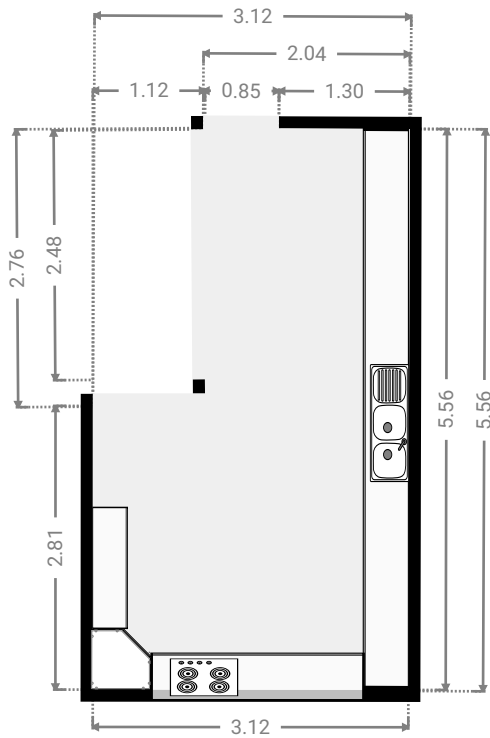
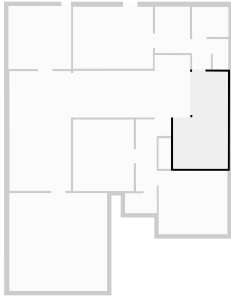

▼ Hall
Ground Floor

WIDTH: 2.01 m • LENGTH: 4.12 m
AREA: 5.67 m² • PERIMETER: 12.26 m

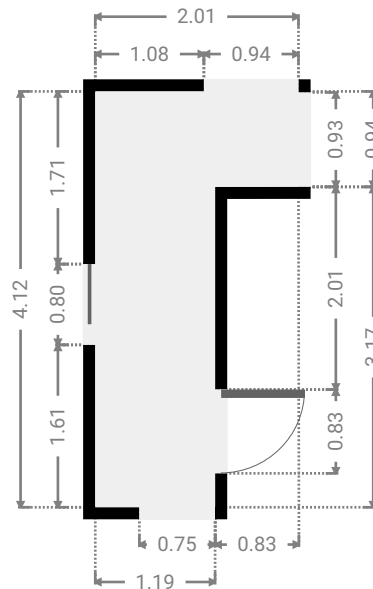
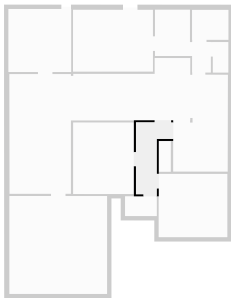

▼ .
Ground Floor

WIDTH: 1.08 m • LENGTH: 1.76 m
AREA: 1.89 m² • PERIMETER: 5.66 m

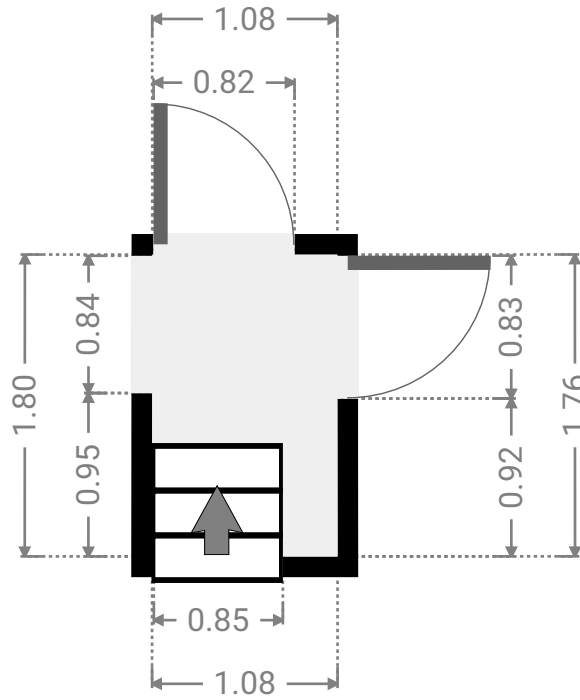
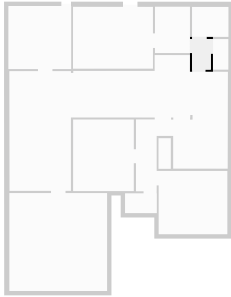

▼ Toilet
Ground Floor

WIDTH: 0.89 m • LENGTH: 1.75 m
AREA: 1.56 m² • PERIMETER: 5.28 m

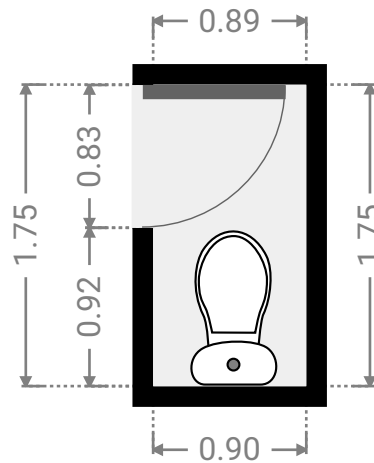
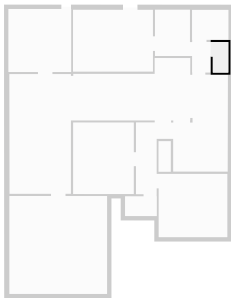

▼ Bathroom
Ground Floor

WIDTH: 2.09 m • LENGTH: 1.72 m
AREA: 3.59 m² • PERIMETER: 7.61 m

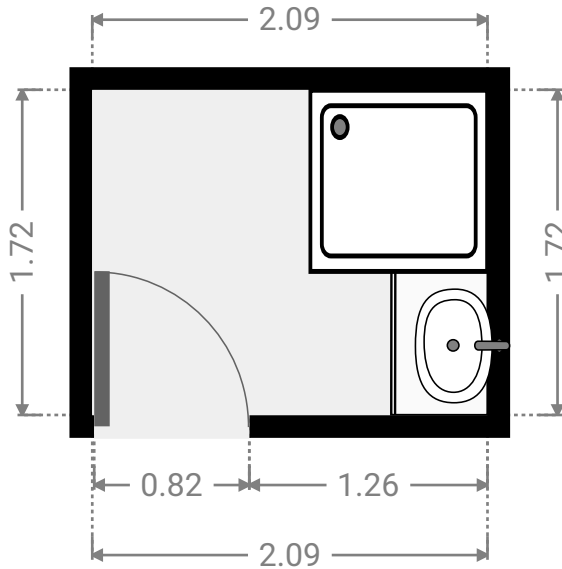
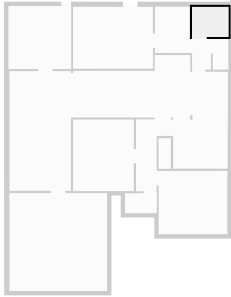

▼ Laundry Room
Ground Floor

WIDTH: 2.01 m • LENGTH: 2.66 m
AREA: 5.33 m² • PERIMETER: 9.32 m

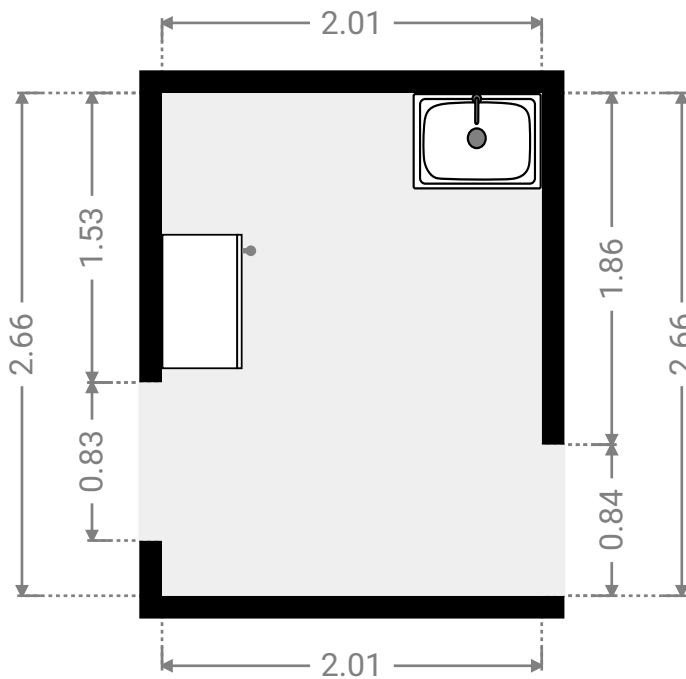
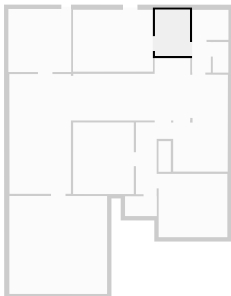

▼ Living Area
Ground Floor

WIDTH: 4.59 m • LENGTH: 3.54 m
AREA: 16.25 m² • PERIMETER: 16.26 m

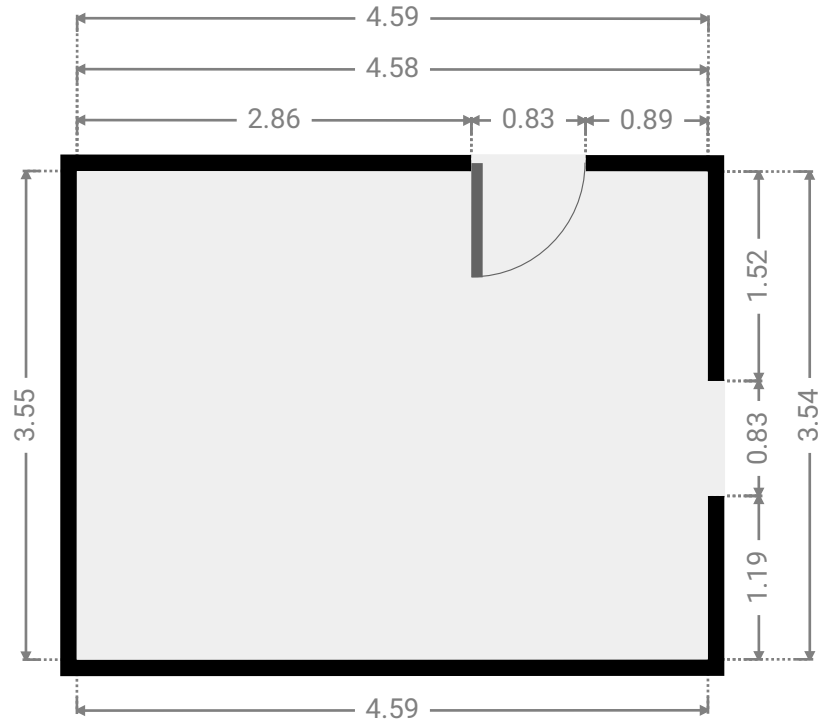
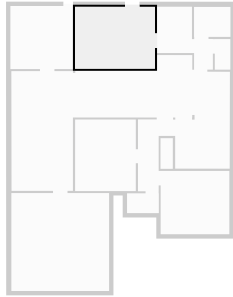

▼ Bedroom
Ground Floor

WIDTH: 3.48 m • LENGTH: 4.11 m
AREA: 14.28 m² • PERIMETER: 15.17 m

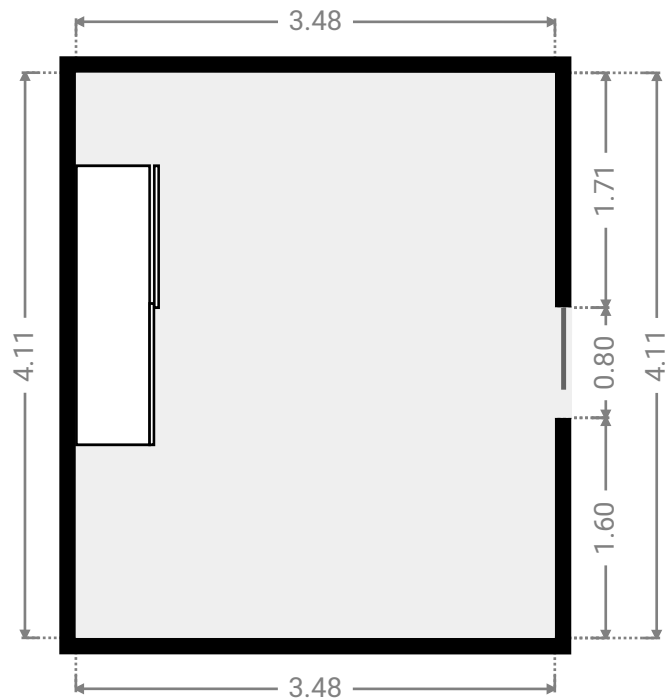
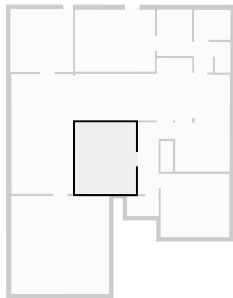

▼ **Bedroom**
Ground Floor

WIDTH: 3.94 m • LENGTH: 3.63 m
AREA: 14.29 m² • PERIMETER: 15.14 m

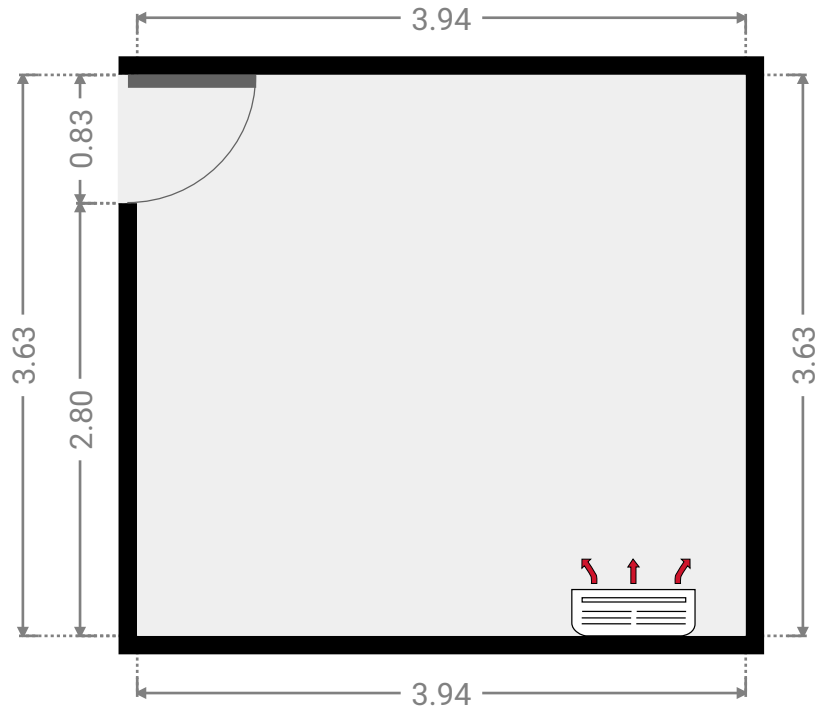
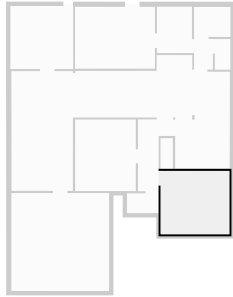

▼ **Closet**
Ground Floor

WIDTH: 0.71 m • LENGTH: 1.76 m
AREA: 1.24 m² • PERIMETER: 4.92 m

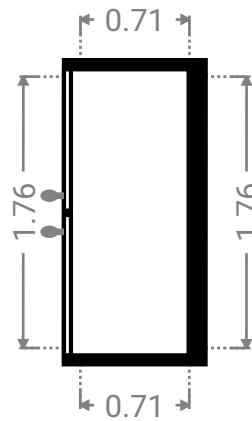
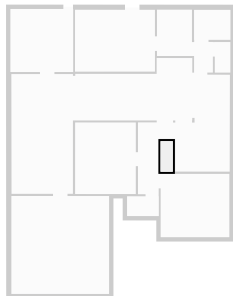

▼ .
Ground Floor

WIDTH: 1.82 m • LENGTH: 1.14 m
AREA: 2.07 m² • PERIMETER: 5.91 m

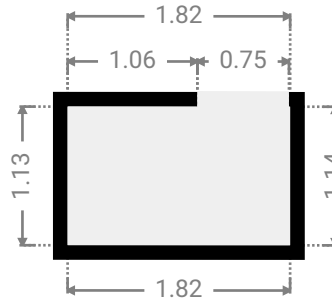
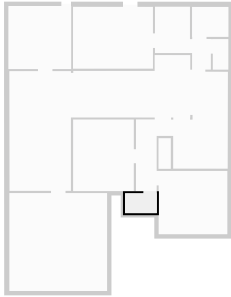

▼ Rear Patio
Ground Floor

WIDTH: 3.60 m • LENGTH: 3.62 m
AREA: 13.02 m² • PERIMETER: 14.43 m

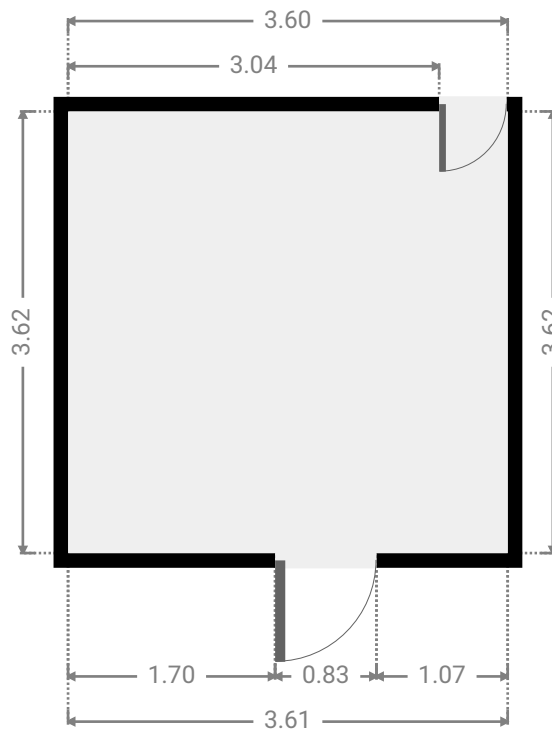
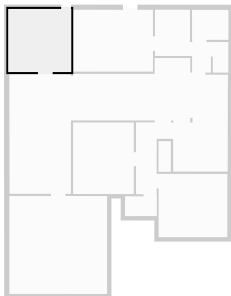

▼ **Carport**
Ground Floor

WIDTH: 5.61 m • LENGTH: 5.62 m
AREA: 31.47 m² • PERIMETER: 22.44 m

