

# 60 Lion Creek Road

**SUBMITTED BY**  
Ray White Rockhampton Casey  
stockers@cqoz.com

---

**CREATED ON**  
2022-03-30

---

**Floors**  
2

---

▼ Ground Floor

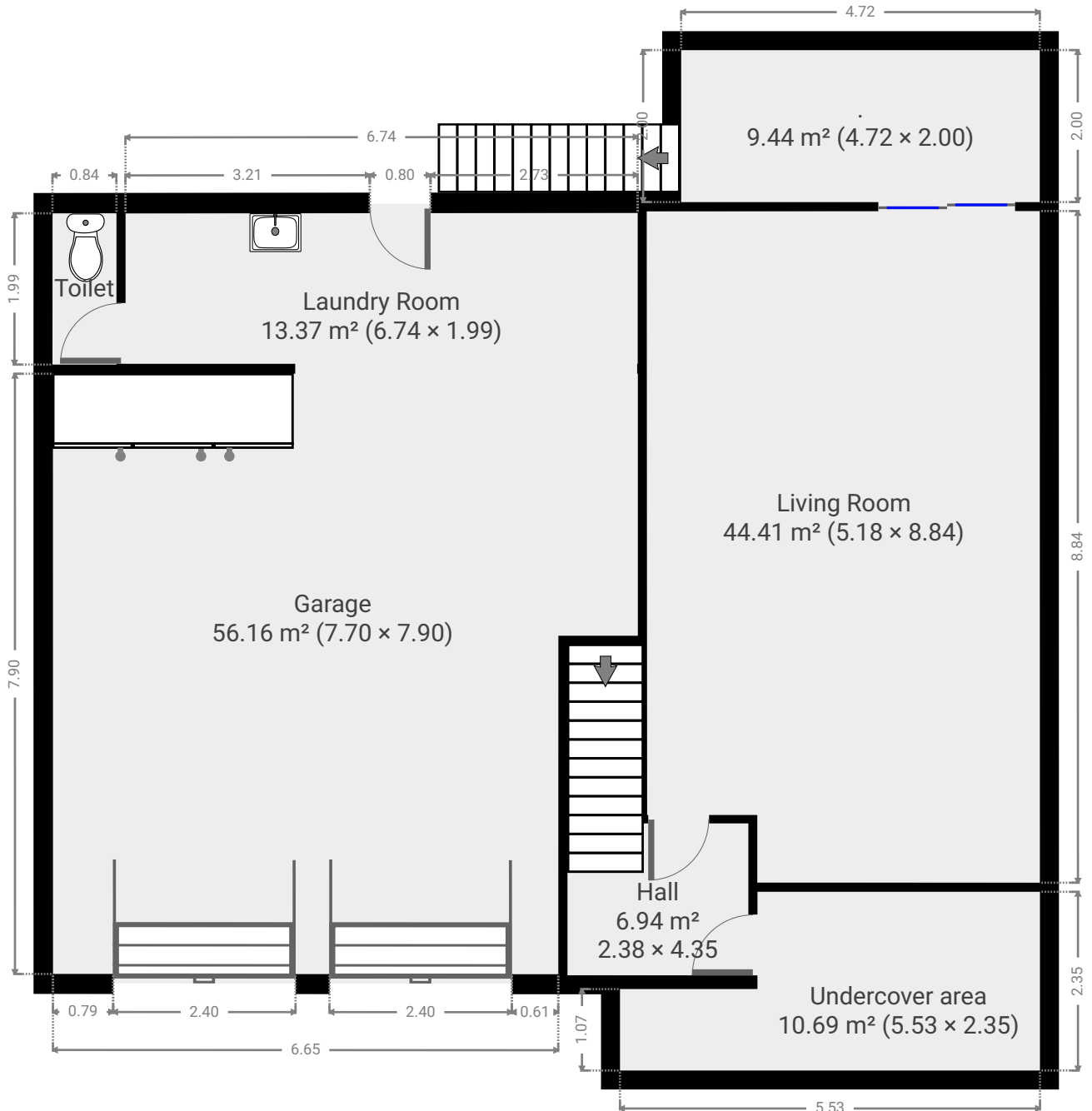

▼ **Living Room**  
Ground Floor

WIDTH: 5.18 m • LENGTH: 8.84 m  
AREA: 44.41 m<sup>2</sup> • PERIMETER: 28.02 m

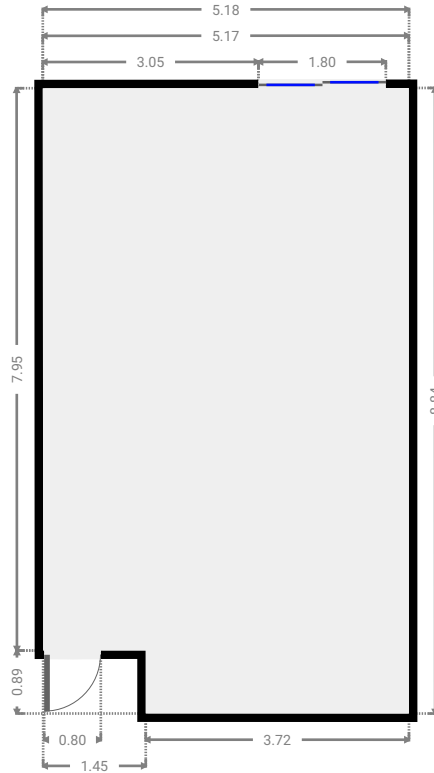
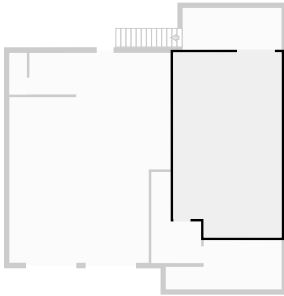

▼ **Hall**  
Ground Floor

WIDTH: 2.38 m • LENGTH: 4.35 m  
AREA: 6.94 m<sup>2</sup> • PERIMETER: 13.46 m

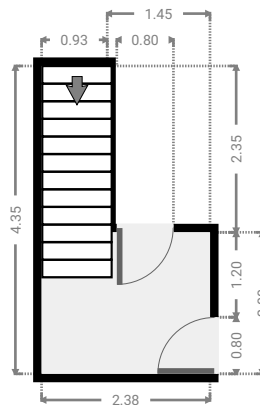
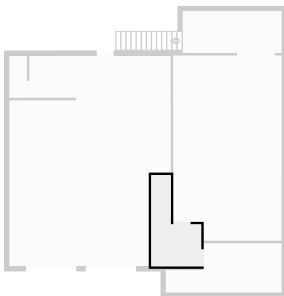

FLOORS: 2

▼ **Garage**  
Ground Floor

WIDTH: 7.70 m • LENGTH: 7.90 m  
AREA: 56.16 m<sup>2</sup> • PERIMETER: 31.20 m

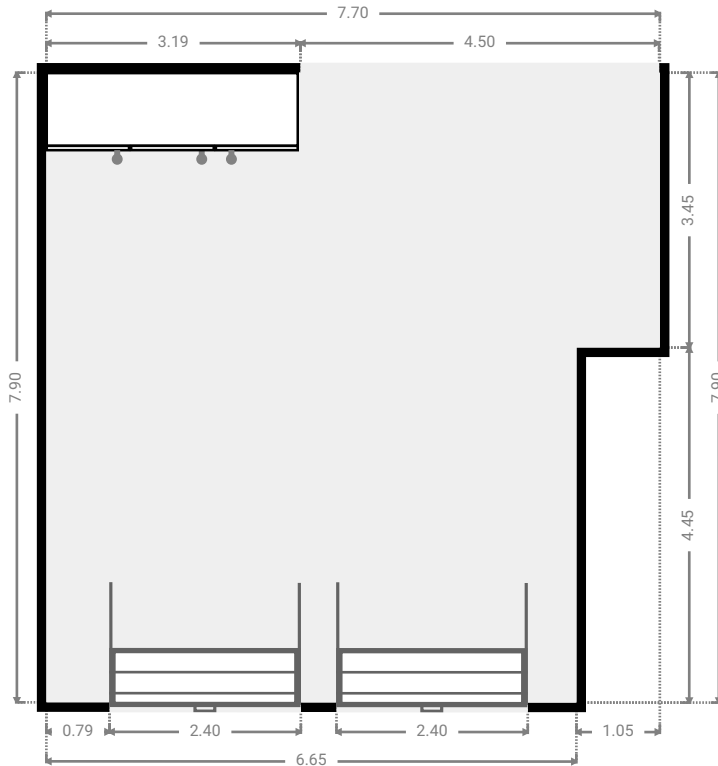
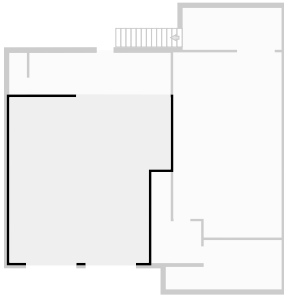

▼ **Laundry Room**  
Ground Floor

WIDTH: 6.74 m • LENGTH: 1.99 m  
AREA: 13.37 m<sup>2</sup> • PERIMETER: 17.45 m

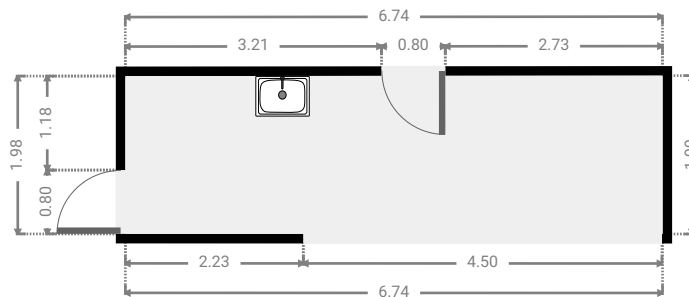
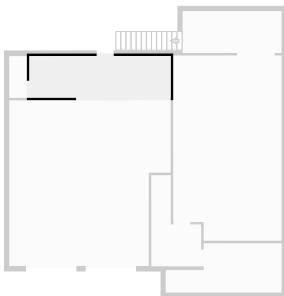

▼ **Toilet**  
Ground Floor

WIDTH: 0.84 m • LENGTH: 1.99 m  
AREA: 1.68 m<sup>2</sup> • PERIMETER: 5.67 m

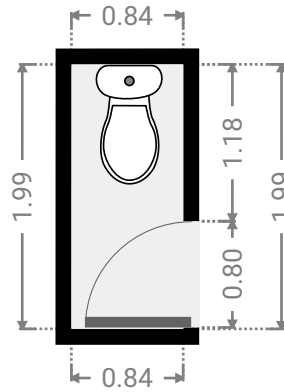
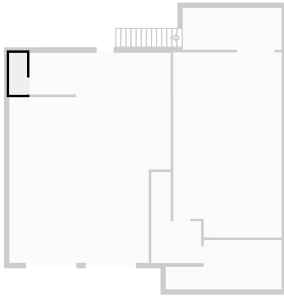

▼ **Undercover area**  
Ground Floor

WIDTH: 5.53 m • LENGTH: 2.35 m  
AREA: 10.69 m<sup>2</sup> • PERIMETER: 15.76 m

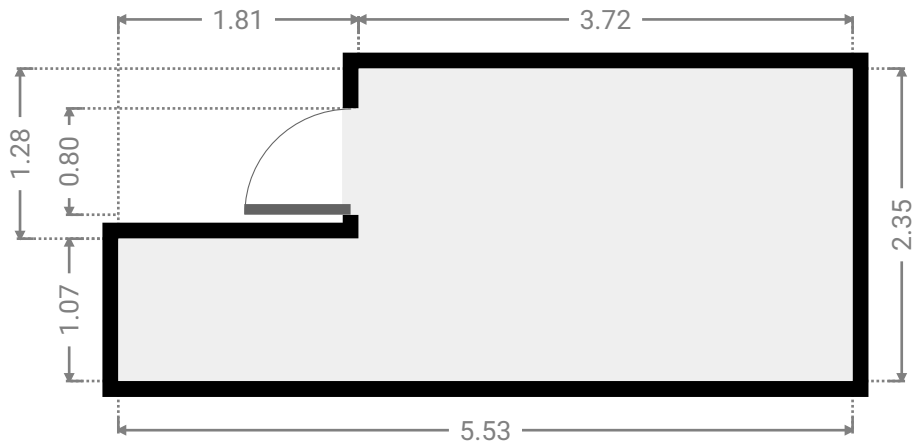
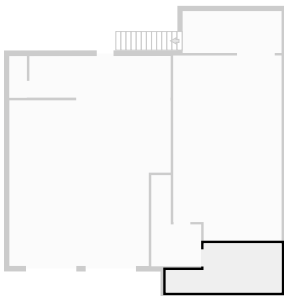

▼ .  
Ground Floor

WIDTH: 4.72 m • LENGTH: 2.00 m  
AREA: 9.44 m<sup>2</sup> • PERIMETER: 13.44 m

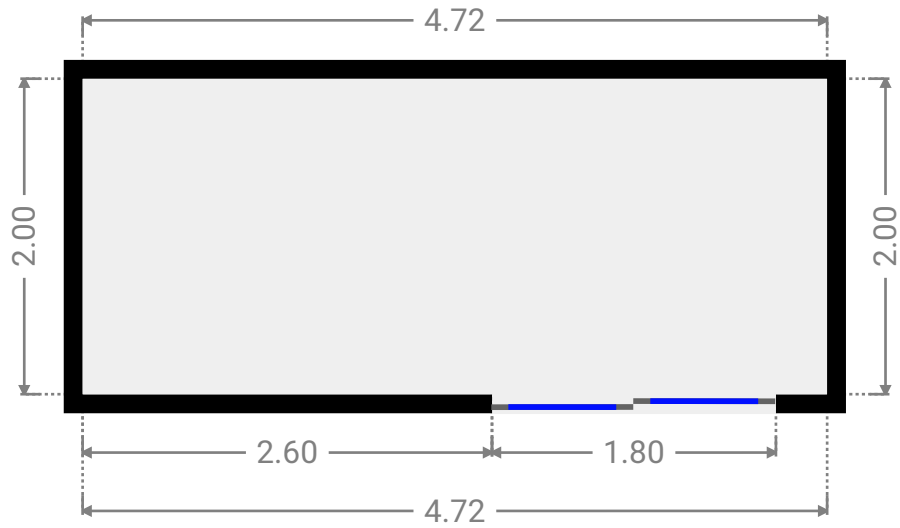
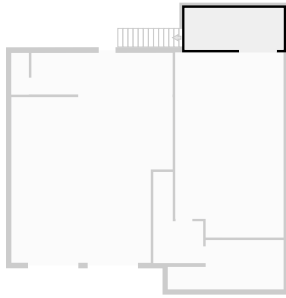

▼ 1st Floor

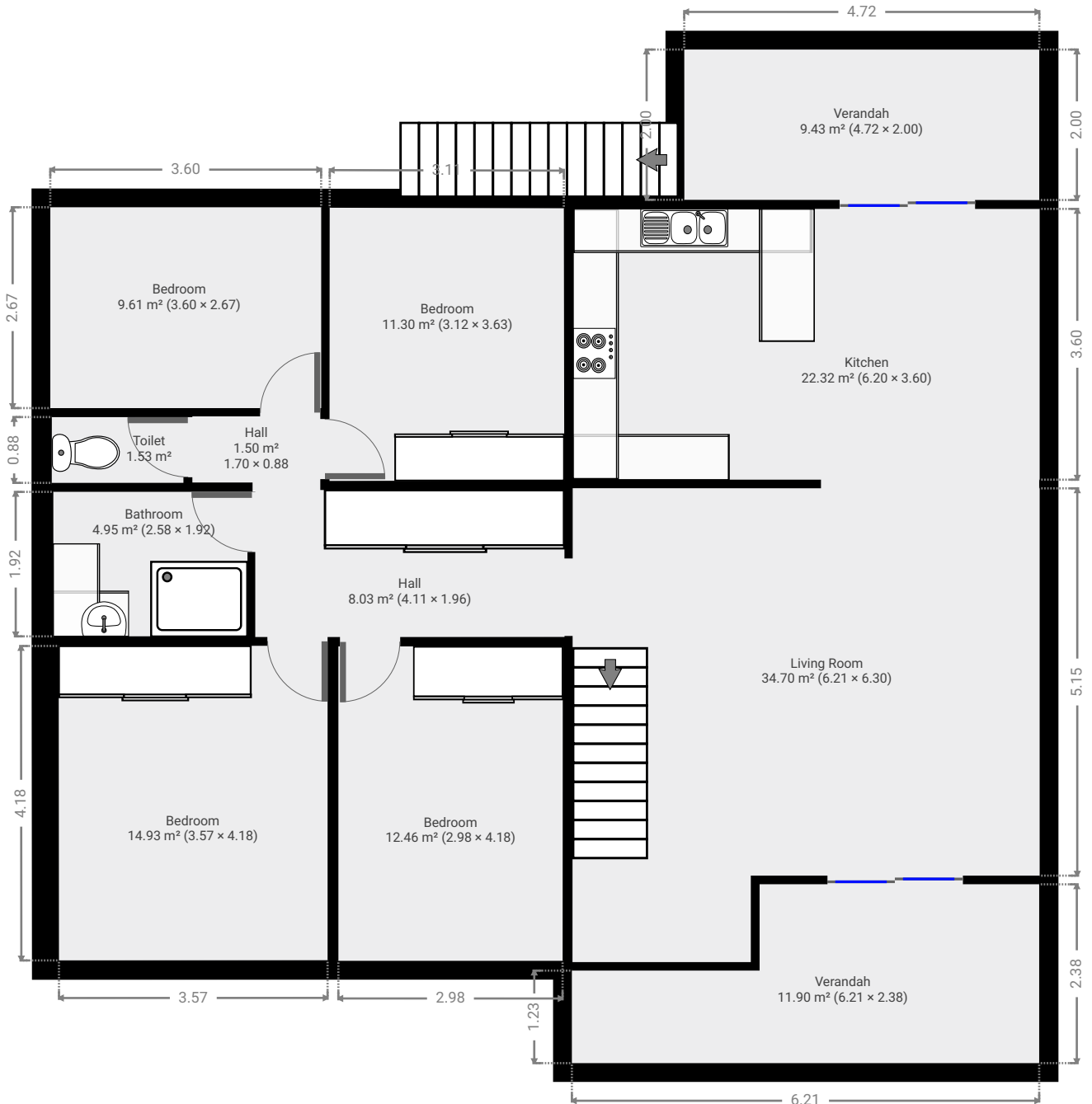

▼ Living Room  
1st Floor

WIDTH: 6.21 m • LENGTH: 6.30 m  
AREA: 34.70 m<sup>2</sup> • PERIMETER: 25.02 m

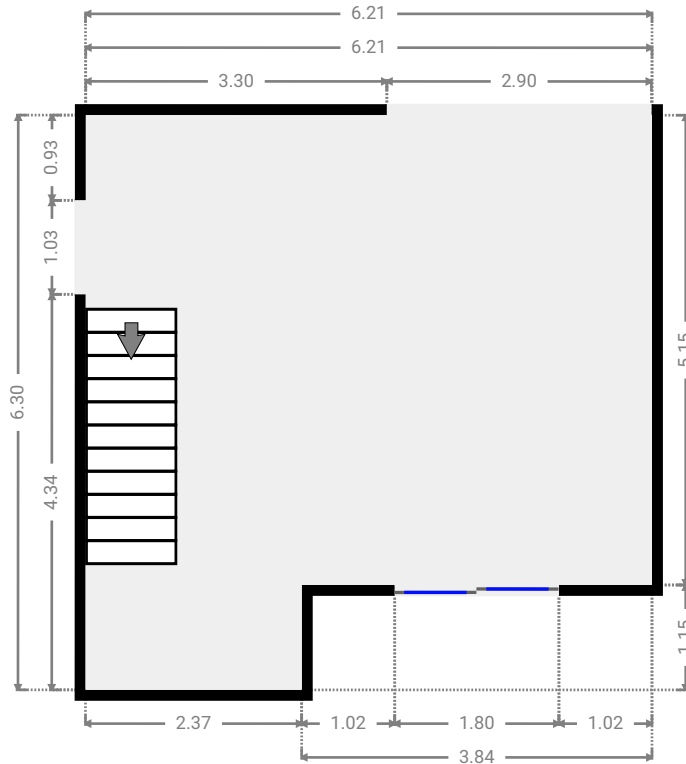
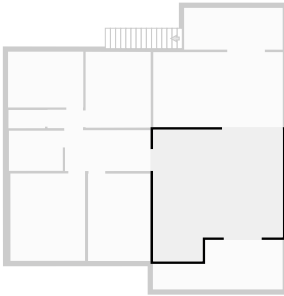

▼ Verandah  
1st Floor

WIDTH: 6.21 m • LENGTH: 2.38 m  
AREA: 11.90 m<sup>2</sup> • PERIMETER: 17.18 m

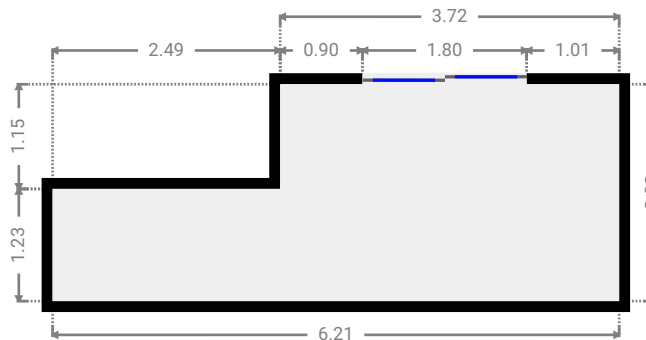
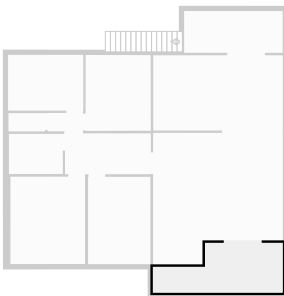



▼ **Kitchen**  
1st Floor

WIDTH: 6.20 m • LENGTH: 3.60 m  
AREA: 22.32 m<sup>2</sup> • PERIMETER: 19.60 m

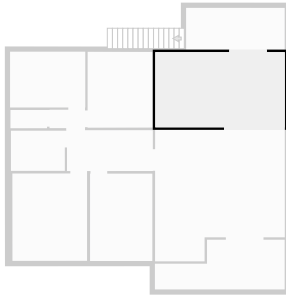

▼ **Hall**  
1st Floor

WIDTH: 4.11 m • LENGTH: 1.96 m  
AREA: 8.03 m<sup>2</sup> • PERIMETER: 12.13 m

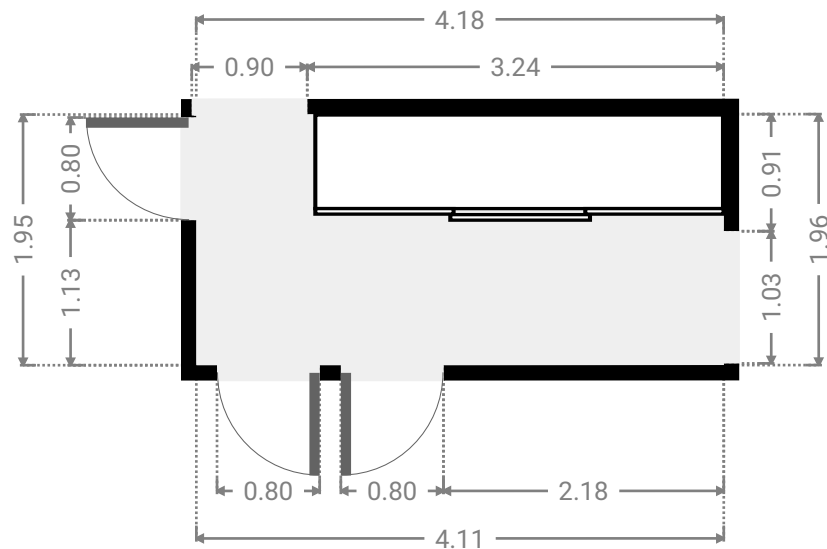
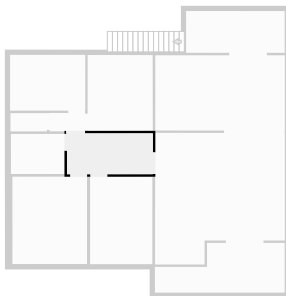

▼ **Bedroom**  
1st Floor

WIDTH: 2.98 m • LENGTH: 4.18 m  
AREA: 12.46 m<sup>2</sup> • PERIMETER: 14.32 m

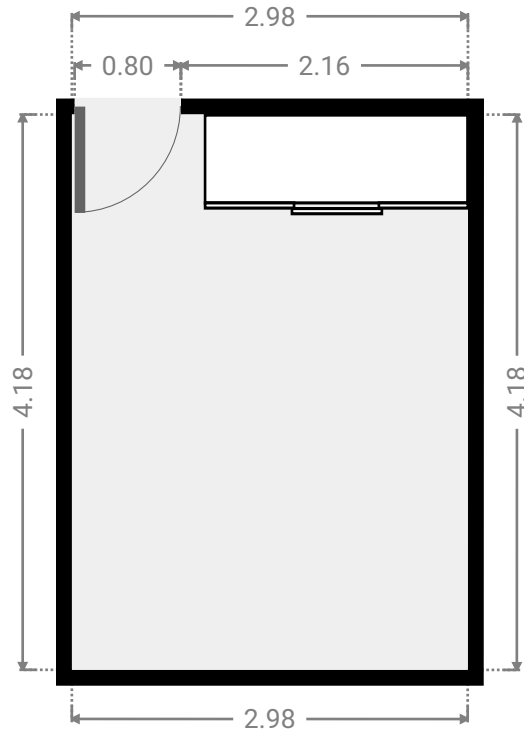
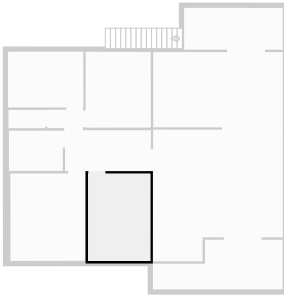

▼ **Bedroom**  
1st Floor

WIDTH: 3.57 m • LENGTH: 4.18 m  
AREA: 14.93 m<sup>2</sup> • PERIMETER: 15.51 m

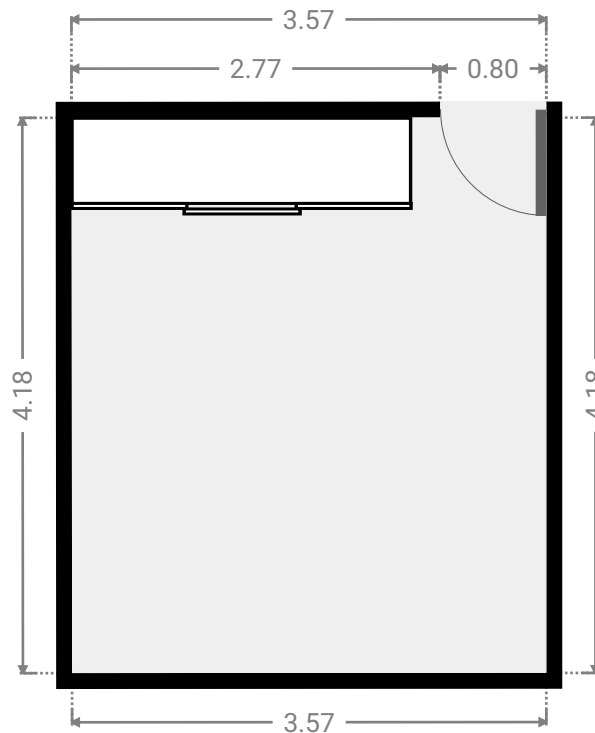
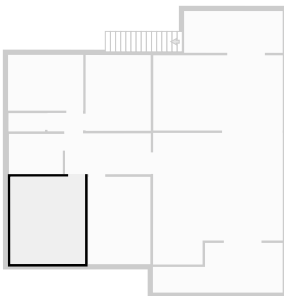

▼ **Bathroom**  
1st Floor

WIDTH: 2.58 m • LENGTH: 1.92 m  
AREA: 4.95 m<sup>2</sup> • PERIMETER: 9.00 m

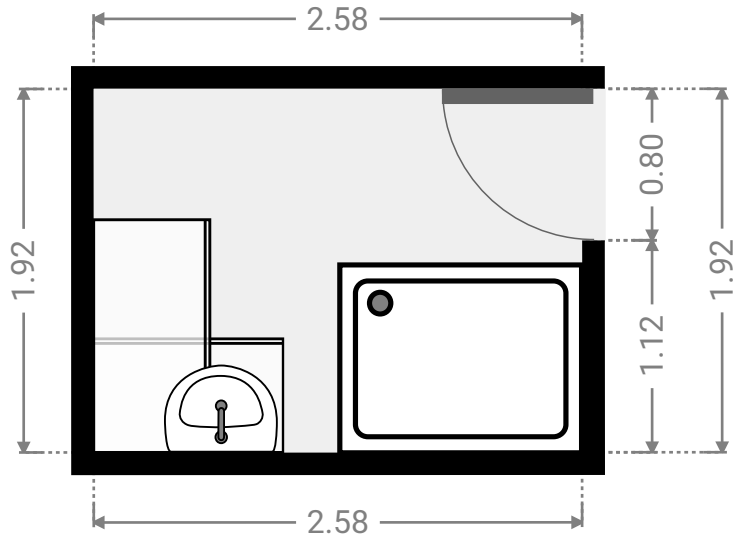
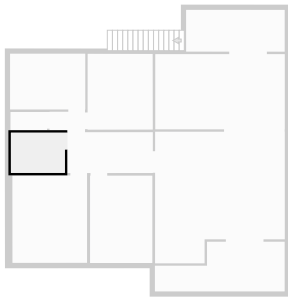

▼ **Hall**  
1st Floor

WIDTH: 1.70 m • LENGTH: 0.88 m  
AREA: 1.50 m<sup>2</sup> • PERIMETER: 5.16 m

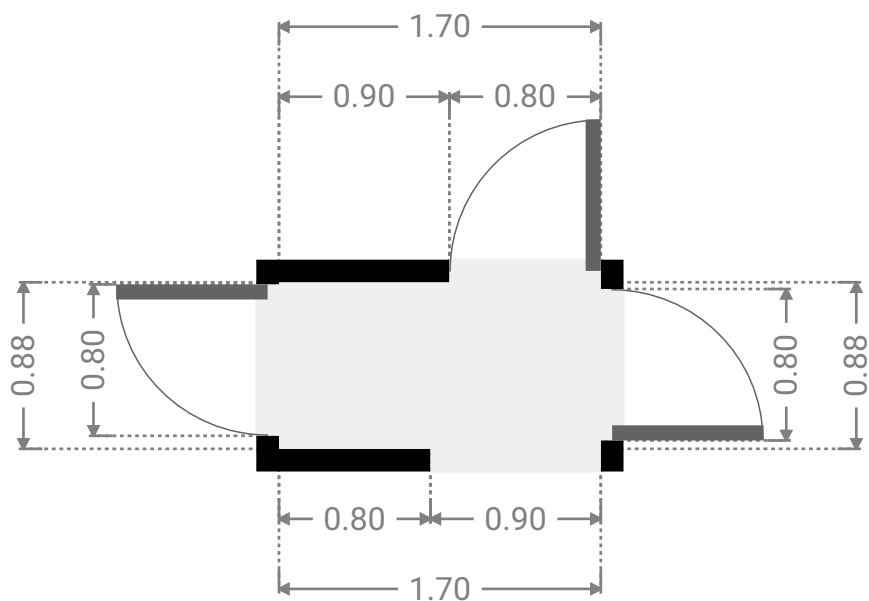
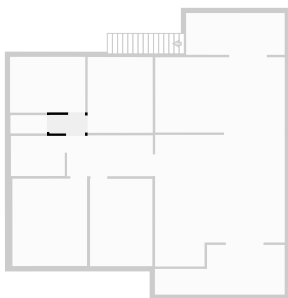

▼ **Toilet**  
1st Floor

WIDTH: 1.75 m • LENGTH: 0.87 m  
AREA: 1.53 m<sup>2</sup> • PERIMETER: 5.25 m

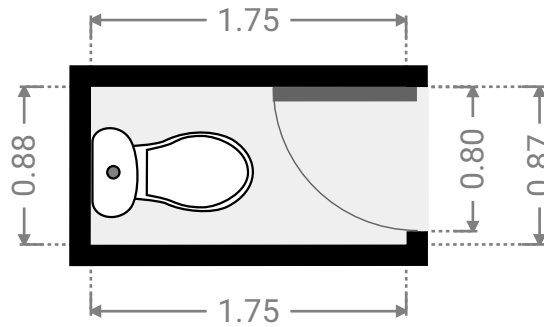
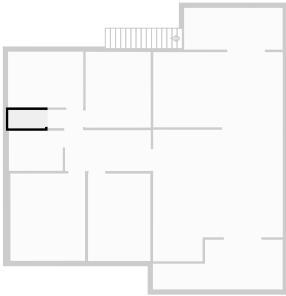

▼ **Bedroom**  
1st Floor

WIDTH: 3.60 m • LENGTH: 2.67 m  
AREA: 9.61 m<sup>2</sup> • PERIMETER: 12.54 m

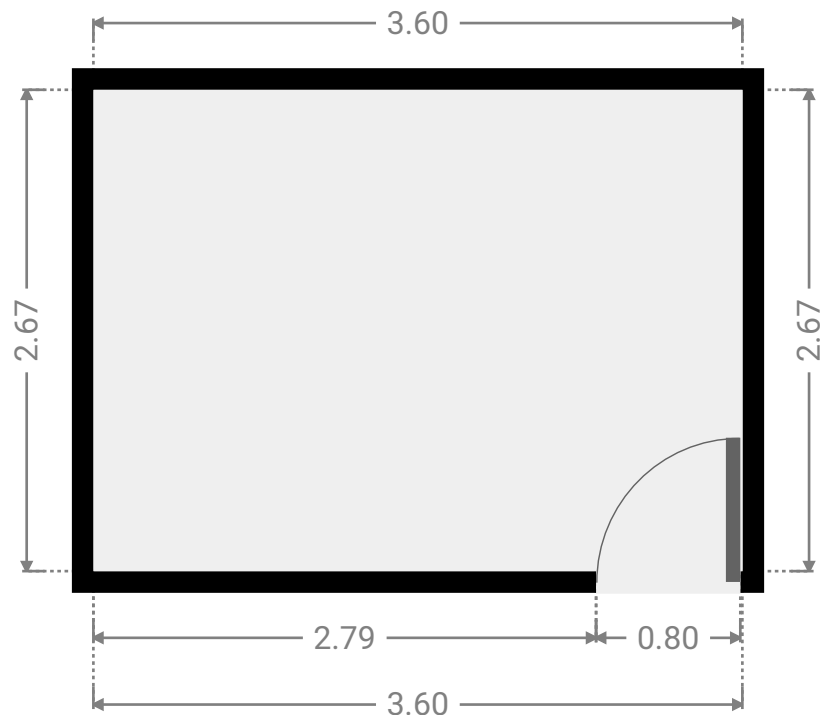
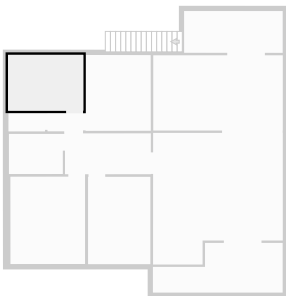

▼ **Bedroom**  
1st Floor

WIDTH: 3.12 m • LENGTH: 3.63 m  
AREA: 11.30 m<sup>2</sup> • PERIMETER: 13.48 m

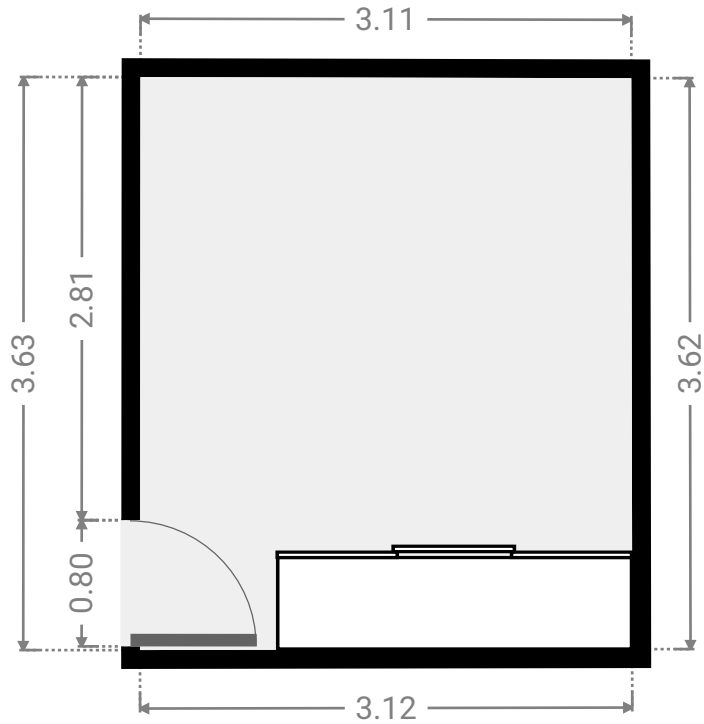
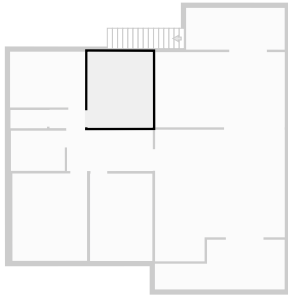

▼ **Verandah**  
1st Floor

WIDTH: 4.72 m • LENGTH: 2.00 m  
AREA: 9.43 m<sup>2</sup> • PERIMETER: 13.43 m

