

60 Leichhardt Drive

SUBMITTED BY
Ray White Rockhampton Casey
stockers@cqoz.com

CREATED ON
2022-06-01

Floors
1

▼ Ground Floor

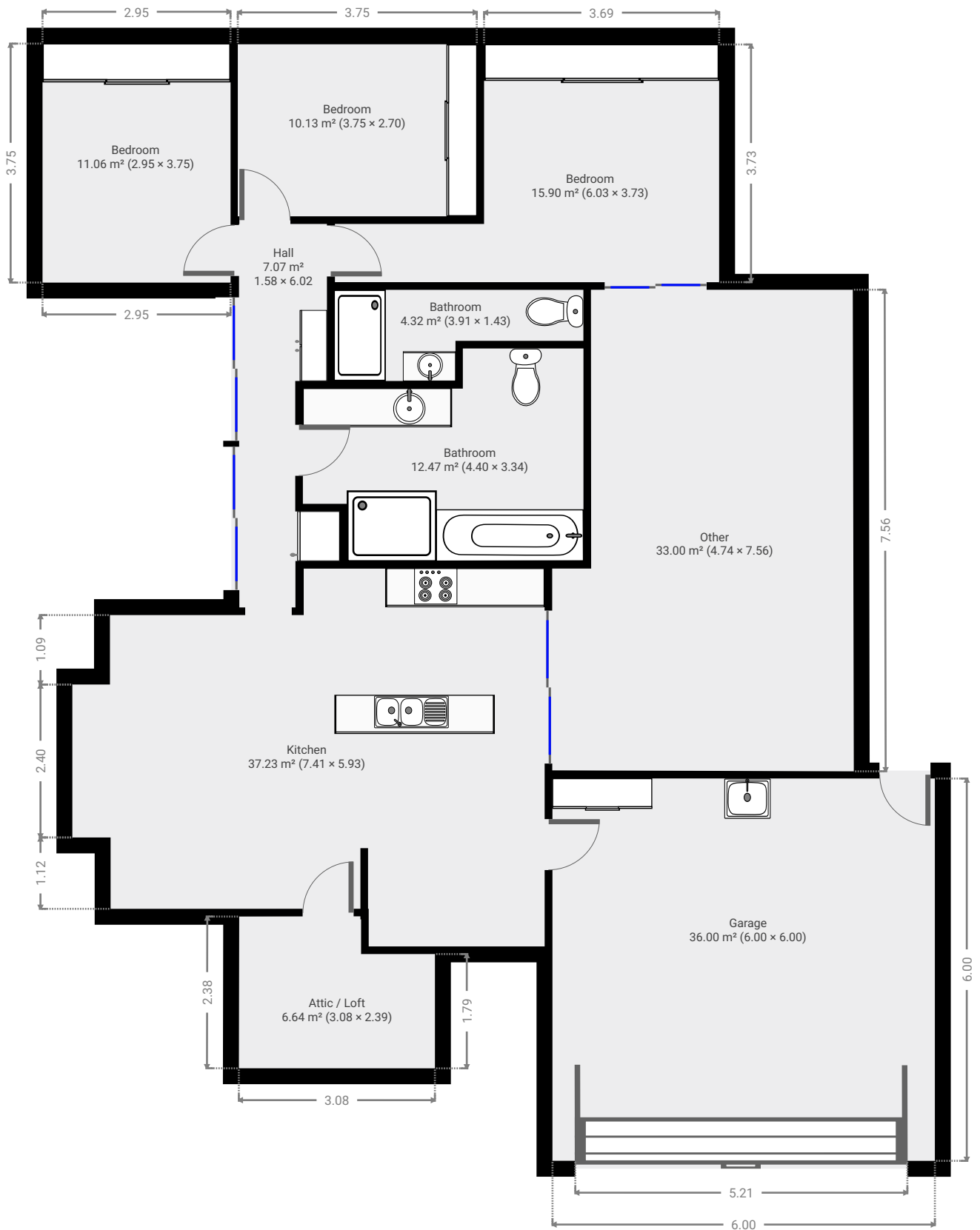

FLOORS: 1

▼ Attic / Loft
Ground Floor

WIDTH: 3.08 m • LENGTH: 2.39 m
AREA: 6.64 m² • PERIMETER: 10.91 m

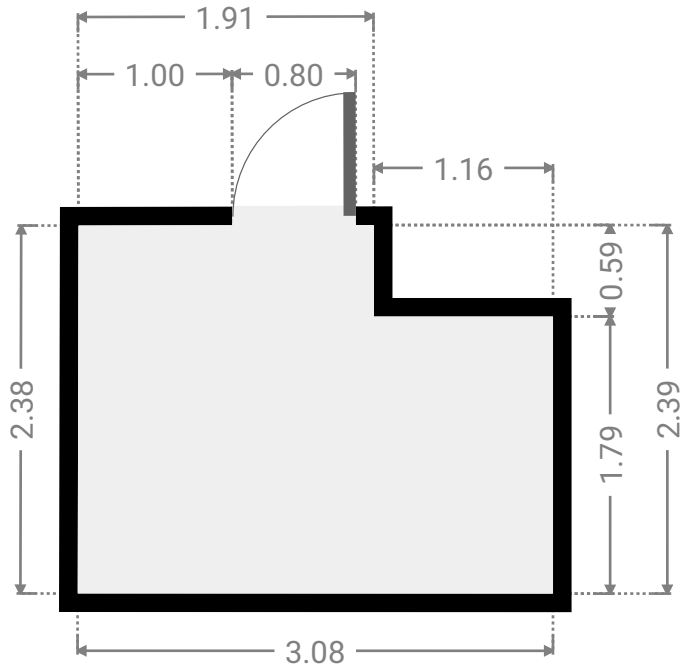
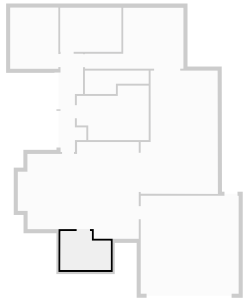

▼ Bathroom
Ground Floor

WIDTH: 4.40 m • LENGTH: 3.34 m
AREA: 12.47 m² • PERIMETER: 15.48 m

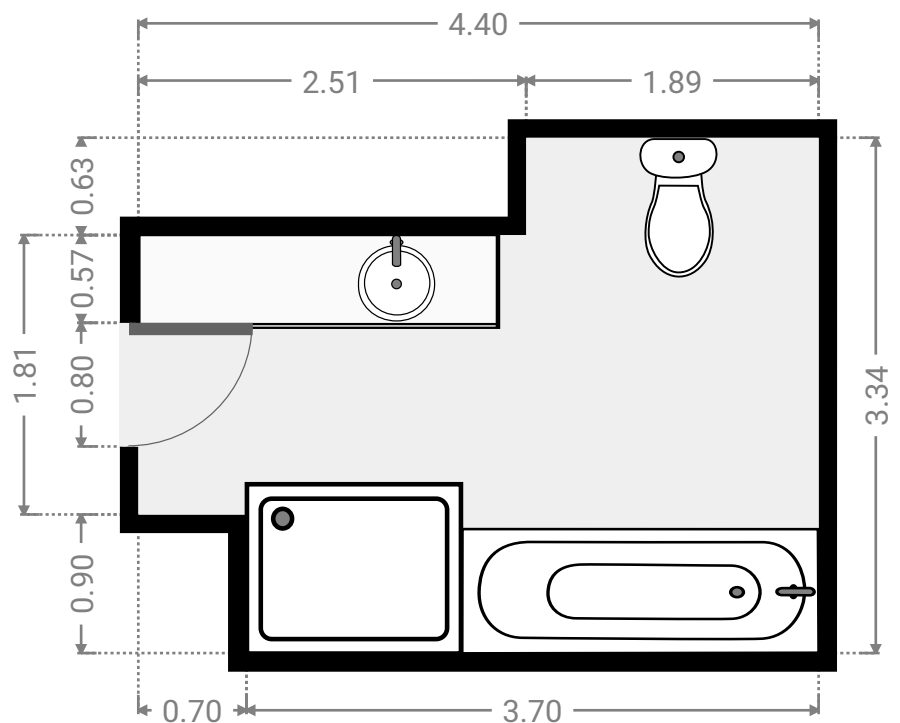
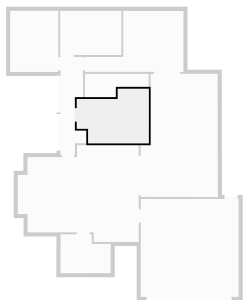

FLOORS: 1

▼ Bathroom
Ground Floor

WIDTH: 3.91 m • LENGTH: 1.43 m
AREA: 4.32 m² • PERIMETER: 10.68 m

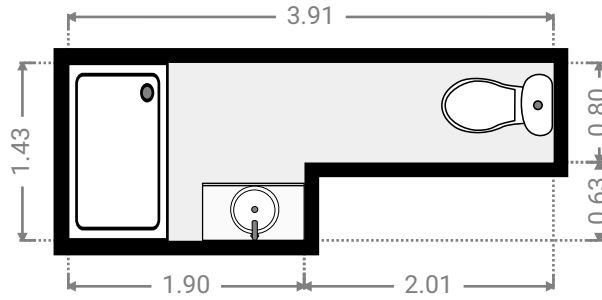
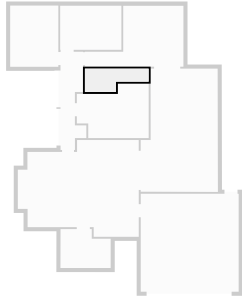

▼ Bedroom
Ground Floor

WIDTH: 6.03 m • LENGTH: 3.73 m
AREA: 15.90 m² • PERIMETER: 19.52 m

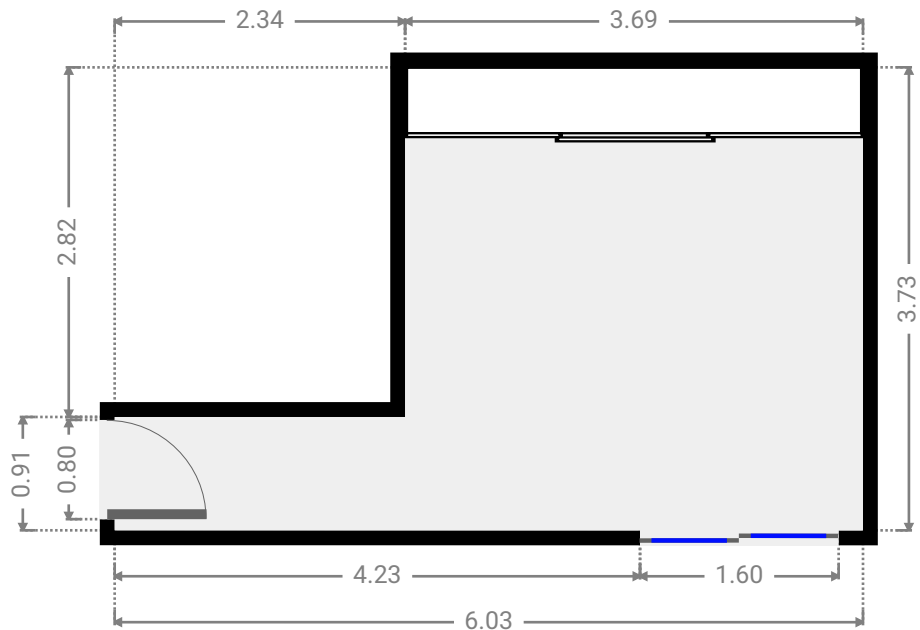
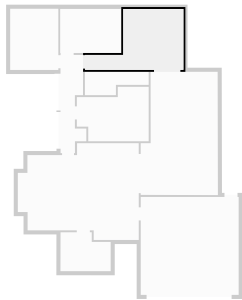

▼ **Bedroom**
Ground Floor

WIDTH: 3.75 m • LENGTH: 2.70 m
AREA: 10.13 m² • PERIMETER: 12.90 m

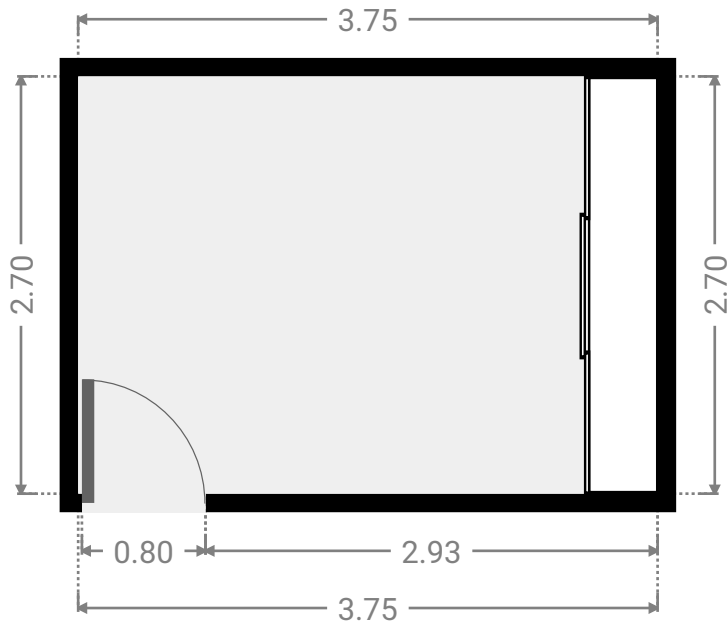
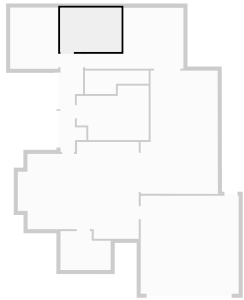

▼ **Bedroom**
Ground Floor

WIDTH: 2.95 m • LENGTH: 3.75 m
AREA: 11.06 m² • PERIMETER: 13.40 m

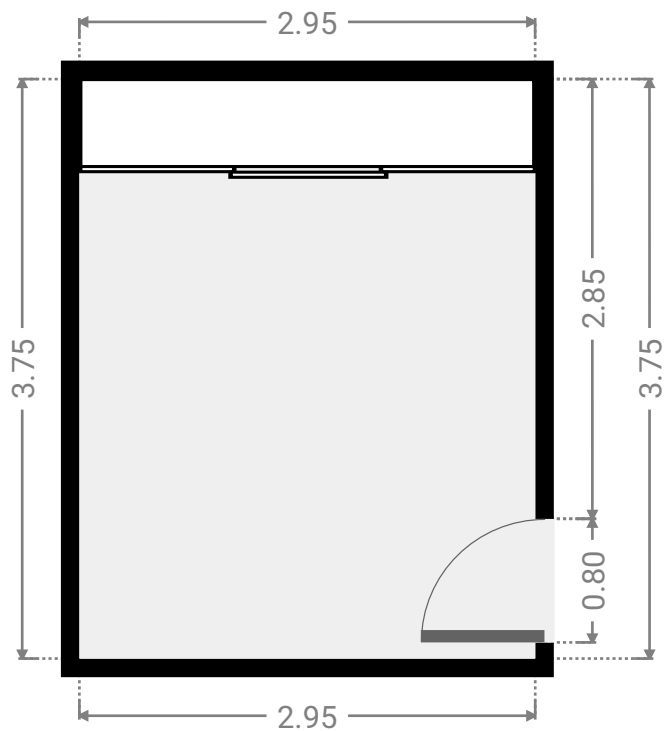
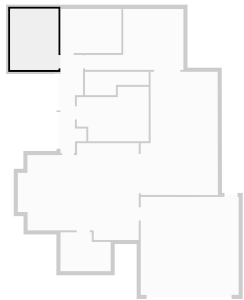

FLOORS: 1

▼ Garage
Ground Floor

WIDTH: 6.00 m • LENGTH: 6.00 m
AREA: 36.00 m² • PERIMETER: 24.00 m

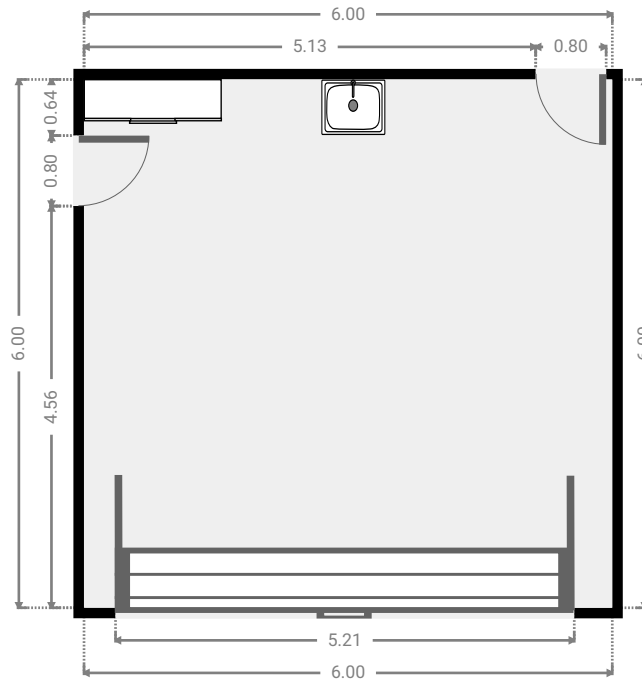
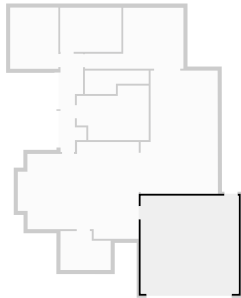

▼ Hall
Ground Floor

WIDTH: 1.58 m • LENGTH: 6.02 m
AREA: 7.07 m² • PERIMETER: 16.19 m

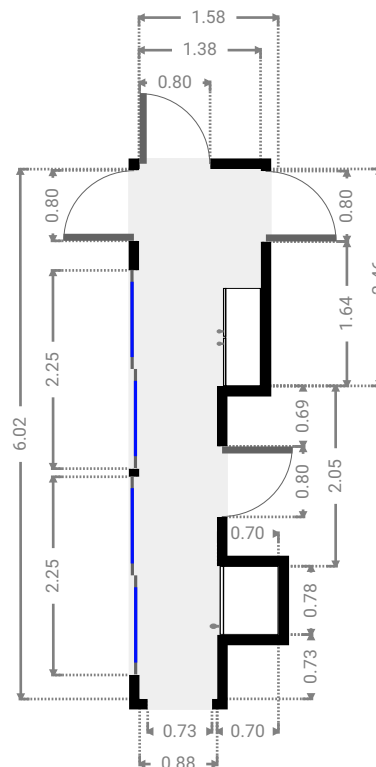
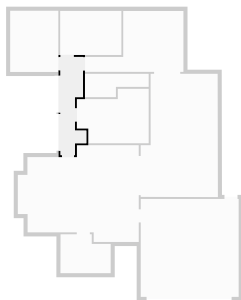

FLOORS: 1

▼ Kitchen
Ground Floor

WIDTH: 7.41 m • LENGTH: 5.93 m
AREA: 37.23 m² • PERIMETER: 26.68 m

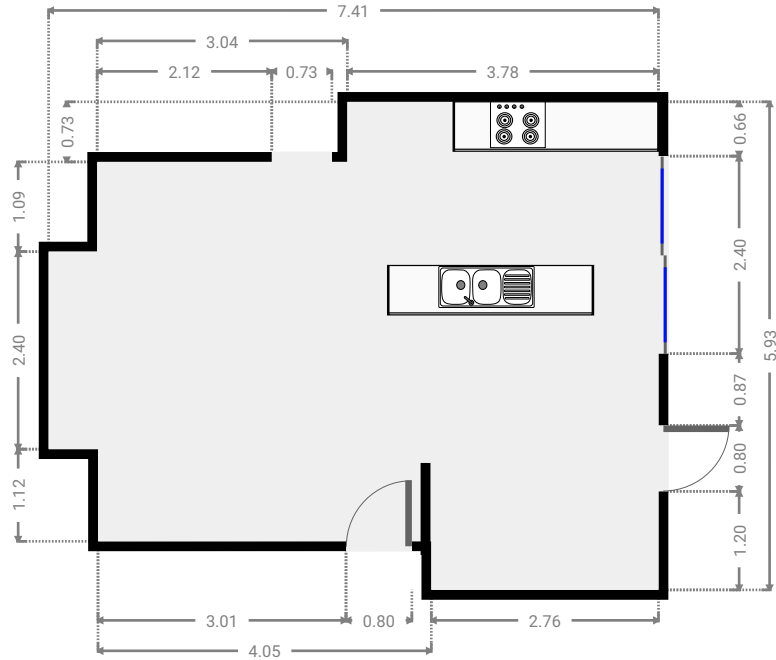
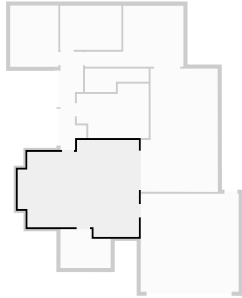

▼ Other
Ground Floor

WIDTH: 4.74 m • LENGTH: 7.56 m
AREA: 33.00 m² • PERIMETER: 24.55 m

