

6 Ruff Street

SUBMITTED BY
Ray White Rockhampton Casey
stockers@cqoz.com

CREATED ON
2022-11-22

Floors
2

▼ Ground Floor

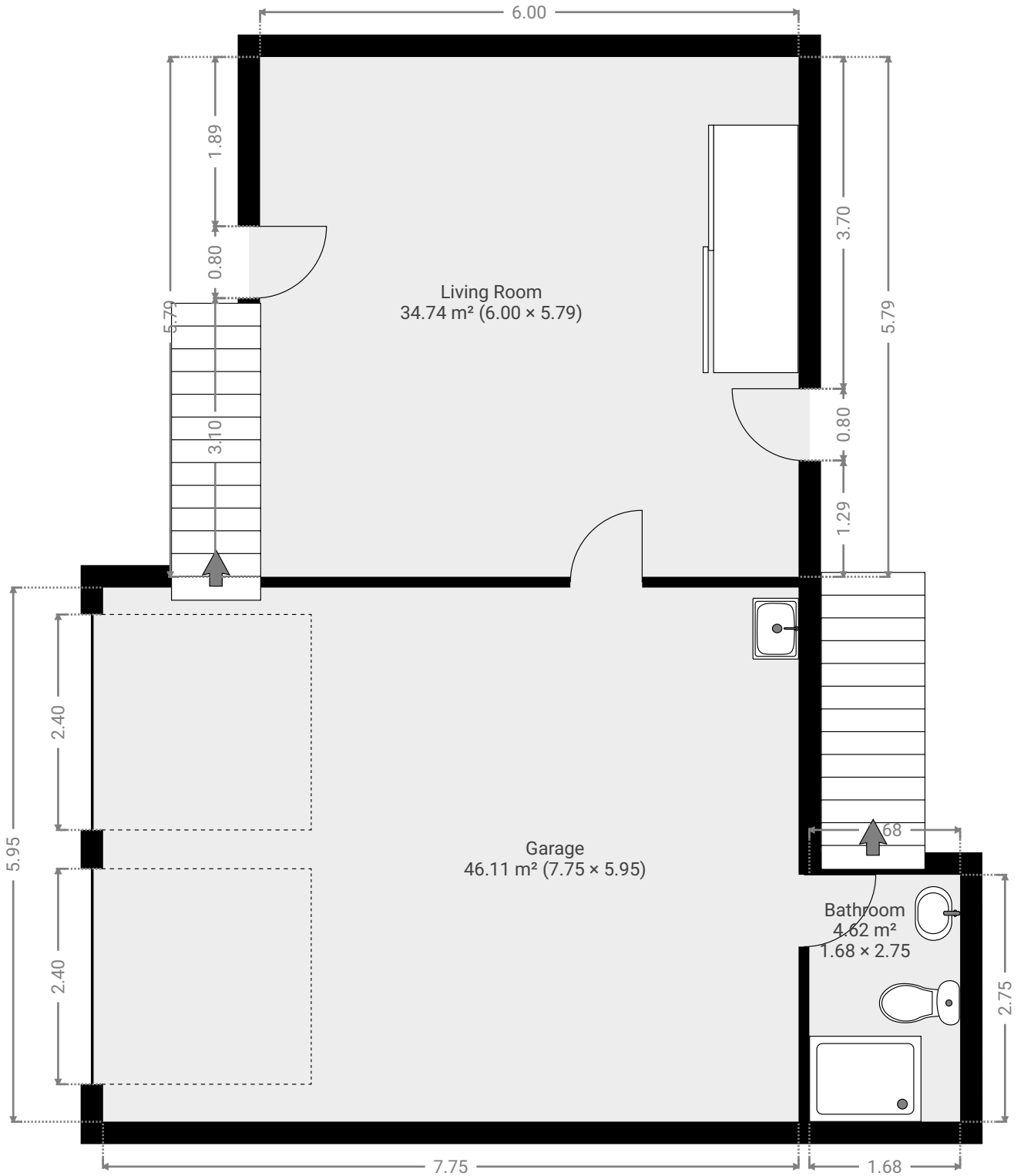

▼ **Bathroom**
Ground Floor

WIDTH: 2.75 m • LENGTH: 1.68 m
AREA: 4.62 m² • PERIMETER: 8.86 m

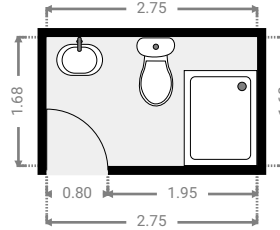
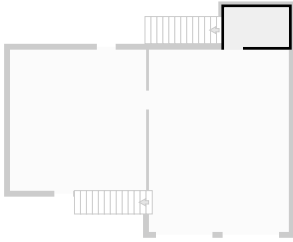

▼ **Garage**
Ground Floor

WIDTH: 5.95 m • LENGTH: 7.75 m
AREA: 46.11 m² • PERIMETER: 27.40 m

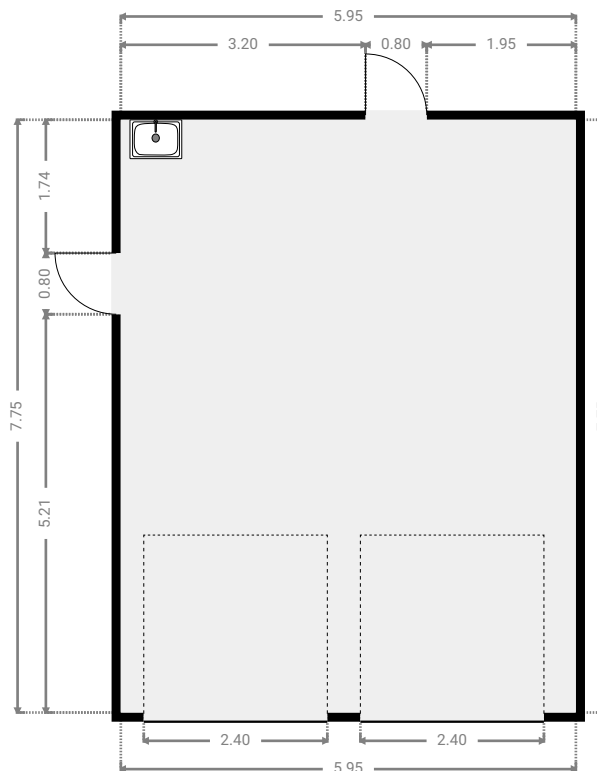
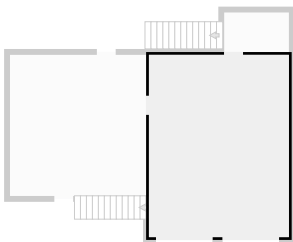

▼ **Living Room**
Ground Floor

WIDTH: 5.79 m • LENGTH: 6.00 m
AREA: 34.74 m² • PERIMETER: 23.58 m

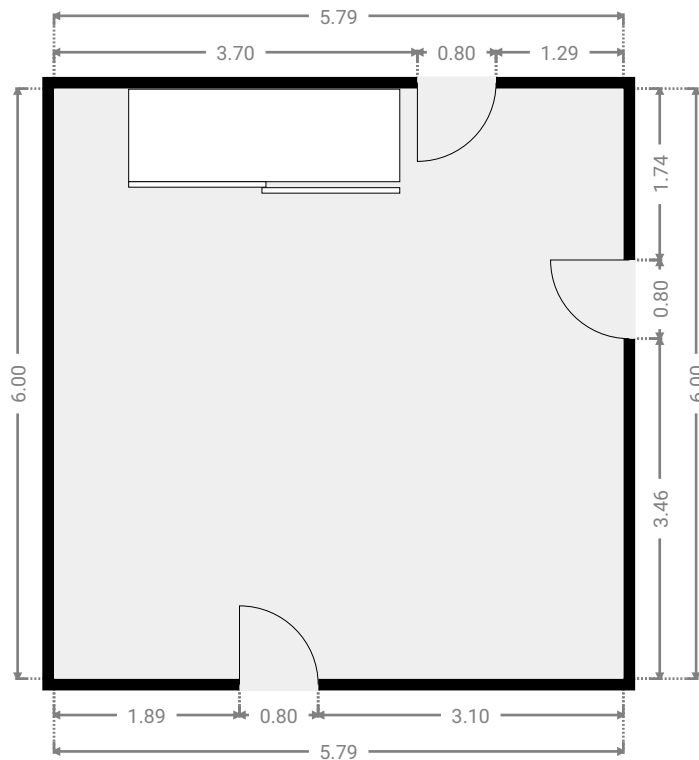
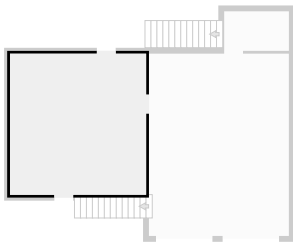

▼ 1st Floor

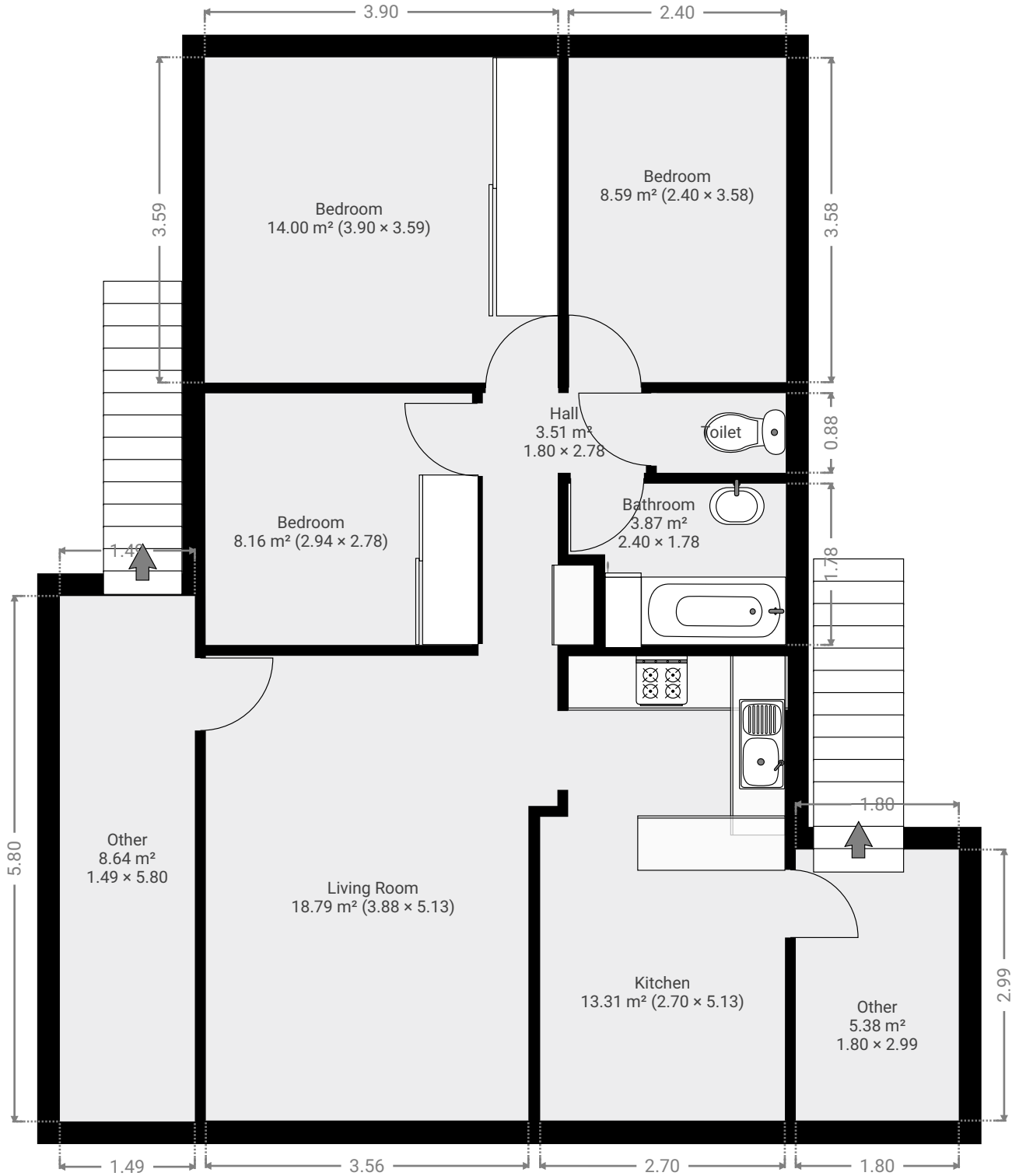

▼ **Bathroom**
1st Floor

WIDTH: 1.78 m • LENGTH: 2.40 m
AREA: 3.87 m² • PERIMETER: 8.36 m

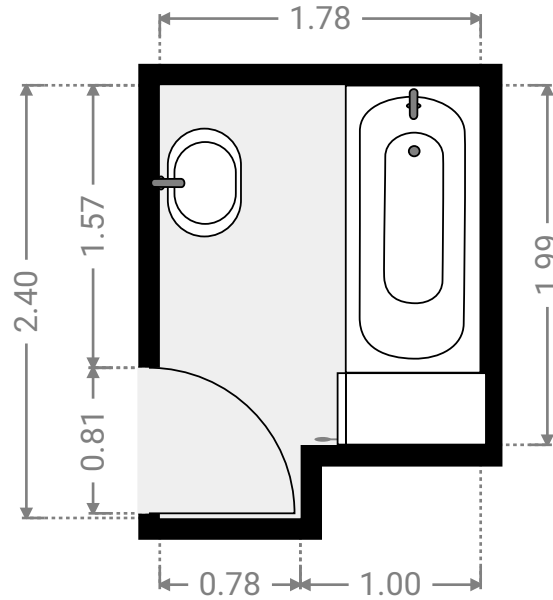
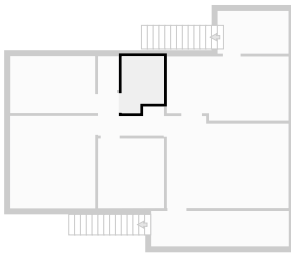

▼ **Bedroom**
1st Floor

WIDTH: 3.58 m • LENGTH: 2.40 m
AREA: 8.59 m² • PERIMETER: 11.96 m

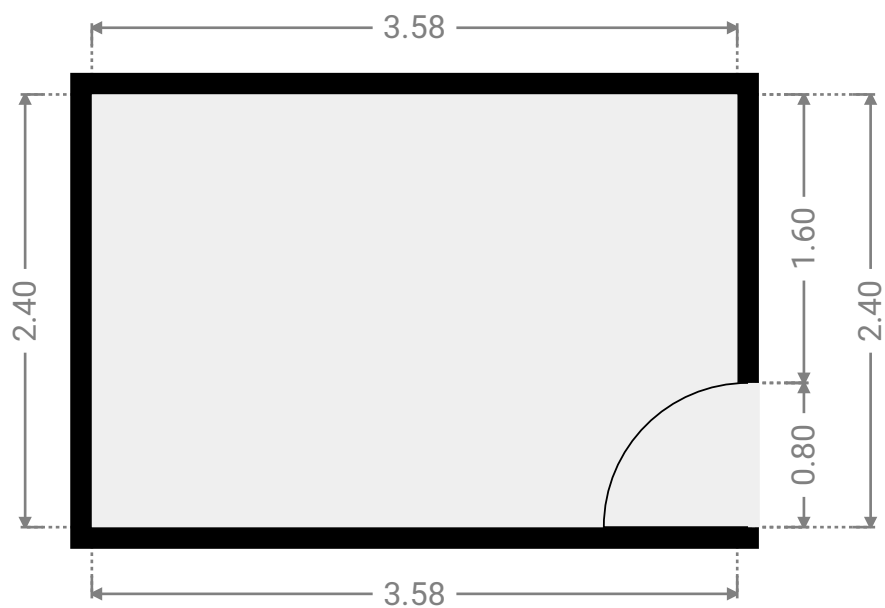
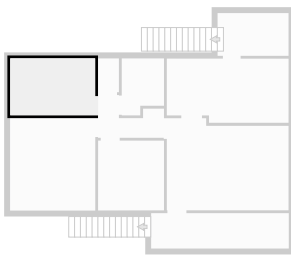

▼ **Bedroom**
1st Floor

WIDTH: 3.59 m • LENGTH: 3.90 m
AREA: 14.00 m² • PERIMETER: 14.98 m

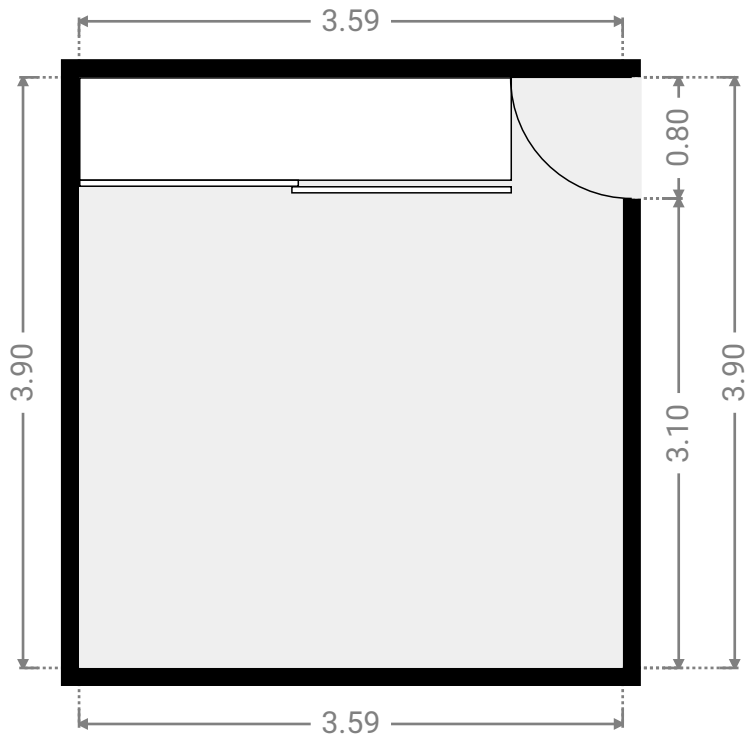
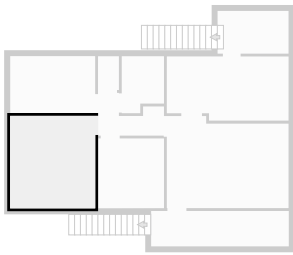

▼ **Bedroom**
1st Floor

WIDTH: 2.78 m • LENGTH: 2.94 m
AREA: 8.16 m² • PERIMETER: 11.43 m

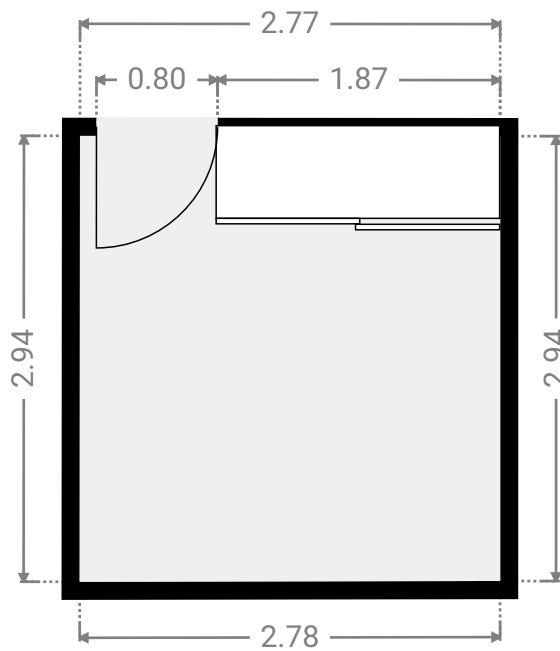
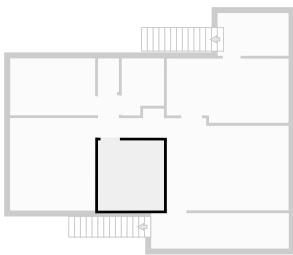

▼ **Hall**
1st Floor

WIDTH: 2.78 m • LENGTH: 1.80 m
AREA: 3.51 m² • PERIMETER: 9.96 m

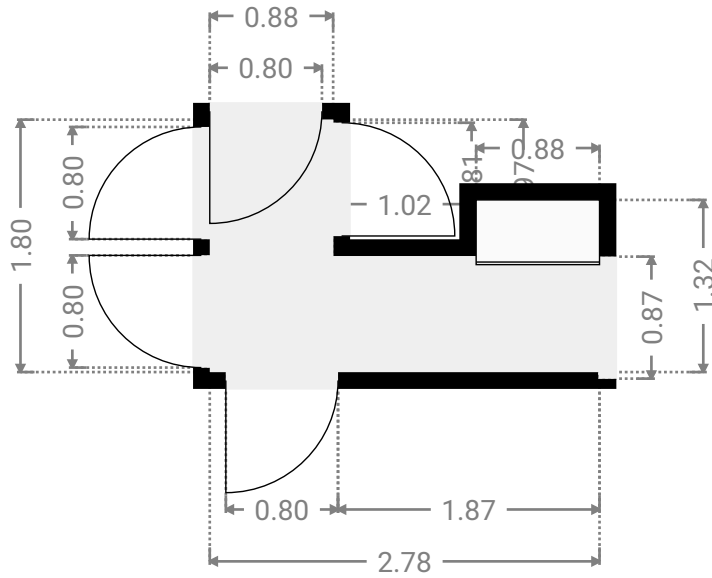
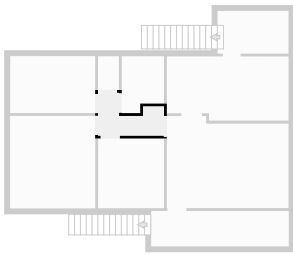

▼ **Kitchen**
1st Floor

WIDTH: 5.13 m • LENGTH: 2.70 m
AREA: 13.31 m² • PERIMETER: 15.66 m

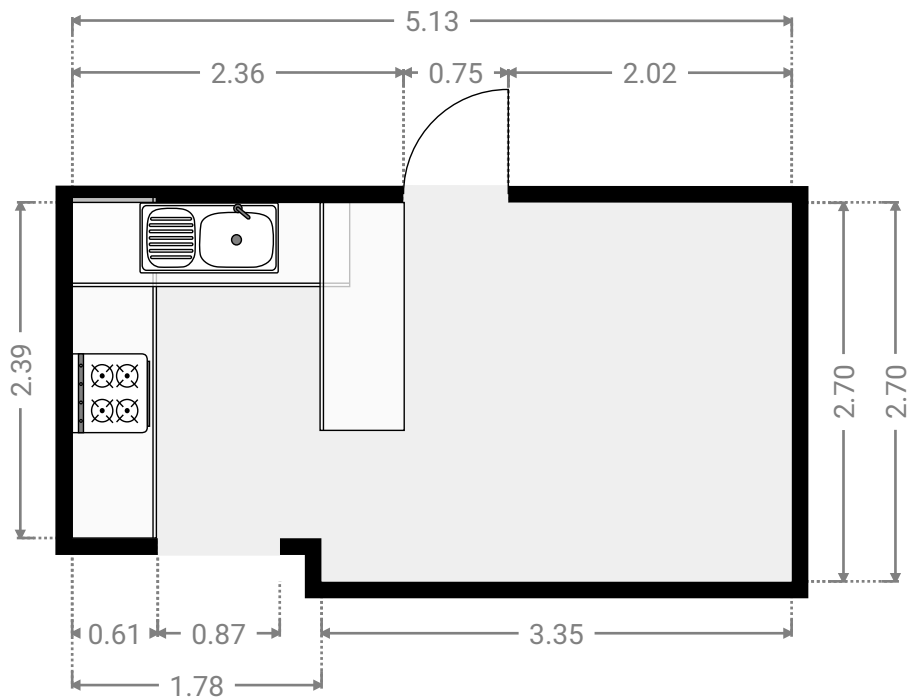
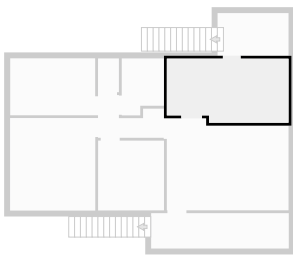

▼ **Living Room**
1st Floor

WIDTH: 5.13 m • LENGTH: 3.88 m
AREA: 18.79 m² • PERIMETER: 18.02 m

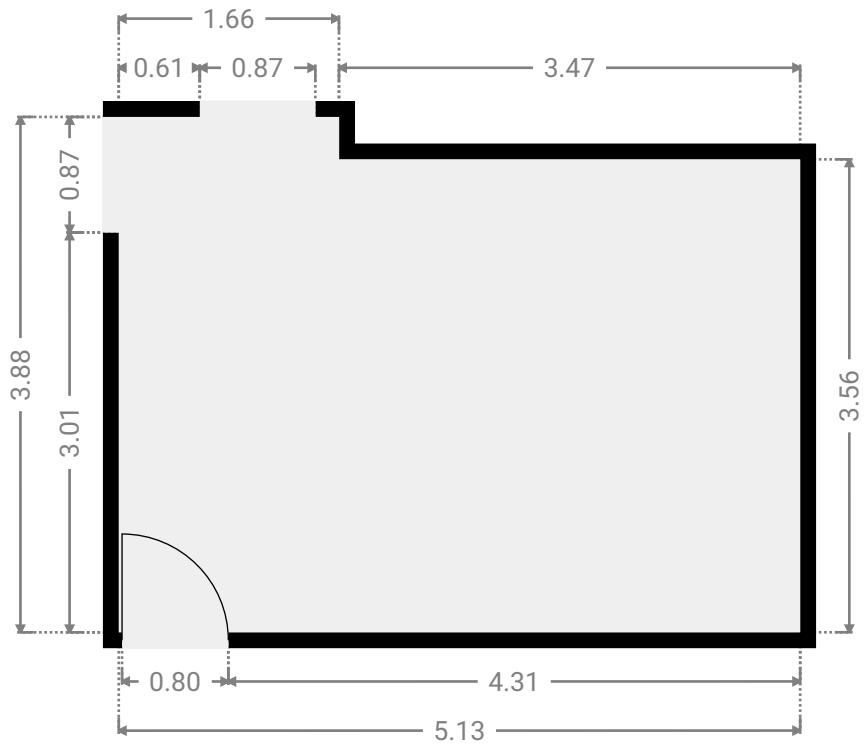
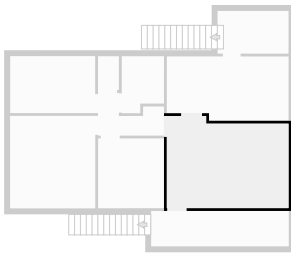

▼ **Other**
1st Floor

WIDTH: 2.99 m • LENGTH: 1.80 m
AREA: 5.38 m² • PERIMETER: 9.58 m

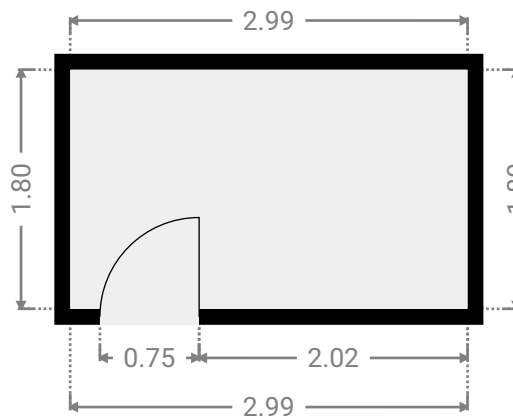
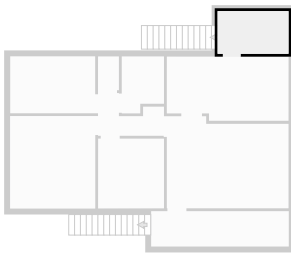

▼ Other
1st Floor

WIDTH: 5.80 m • LENGTH: 1.49 m
AREA: 8.64 m² • PERIMETER: 14.58 m

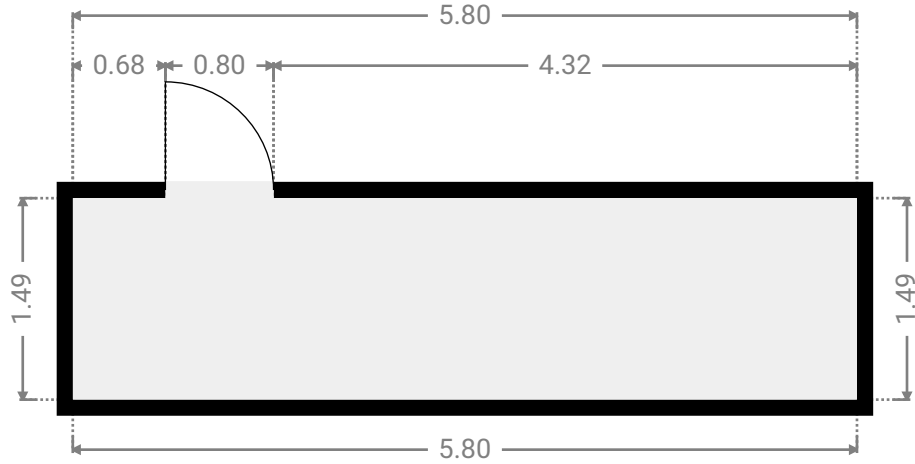
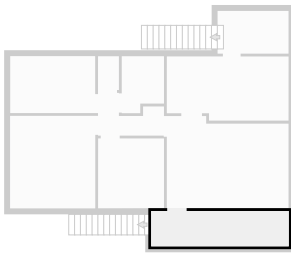

▼ Toilet
1st Floor

WIDTH: 0.88 m • LENGTH: 1.42 m
AREA: 1.25 m² • PERIMETER: 4.61 m

