

6 Mercer Street

Ground Floor

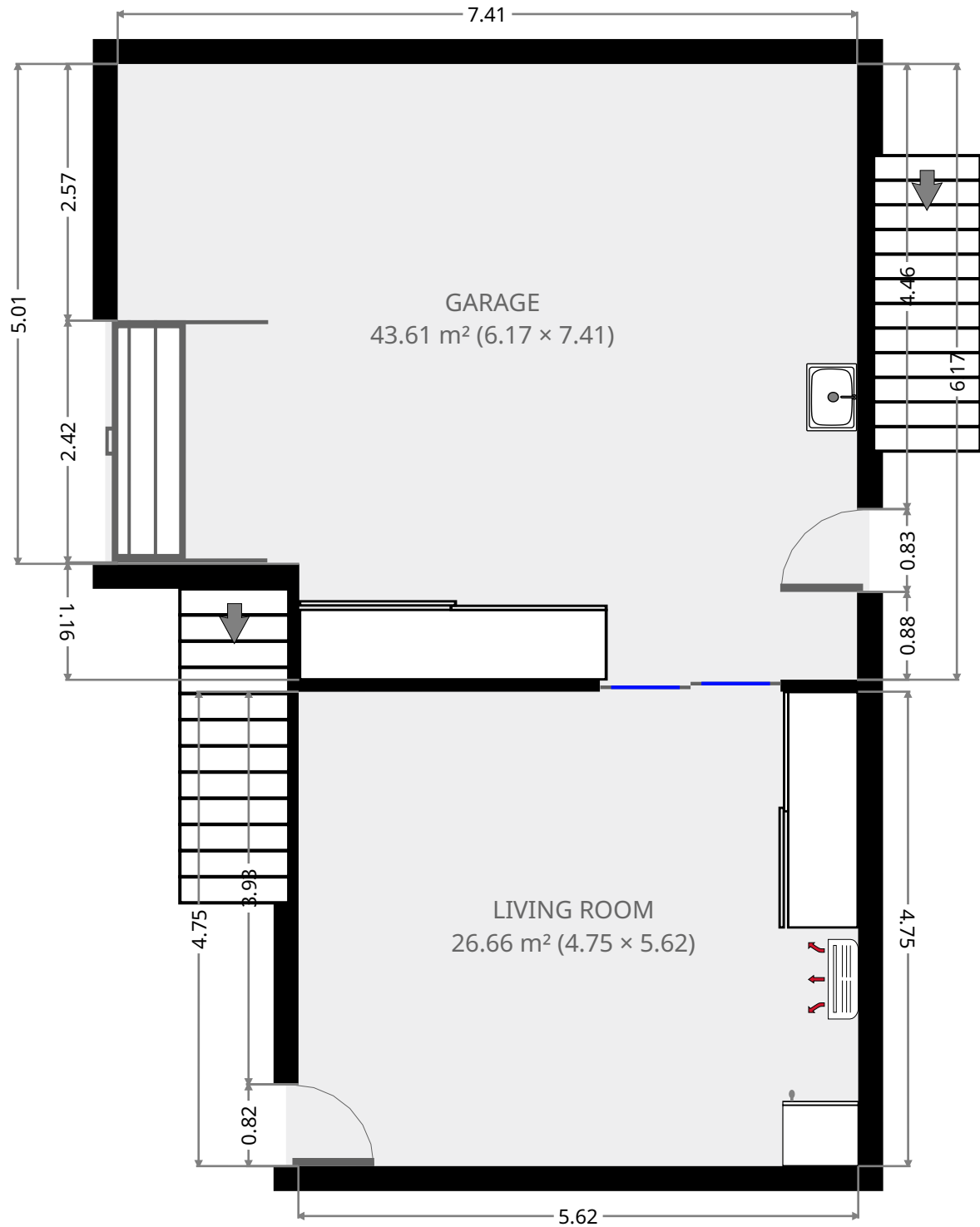

THIS FLOORPLAN IS PROVIDED WITHOUT WARRANTY OF ANY KIND. SENSOPIA DISCLAIMS ANY WARRANTY INCLUDING, WITHOUT LIMITATION, SATISFACTORY QUALITY OR ACCURACY OF DIMENSIONS.

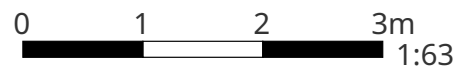

6 Mercer Street

Living Room

Width: 4.75 m
 Length: 5.62 m
 Area: 26.66 m²
 Perimeter: 20.72 m

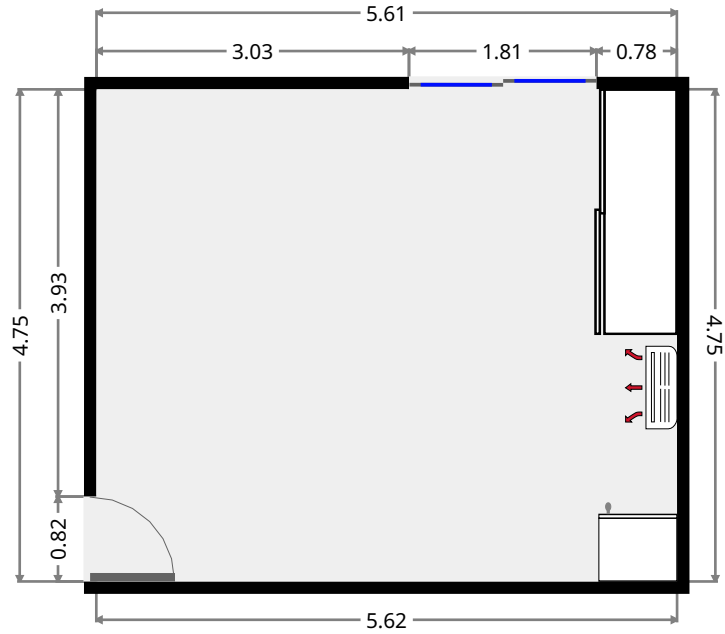
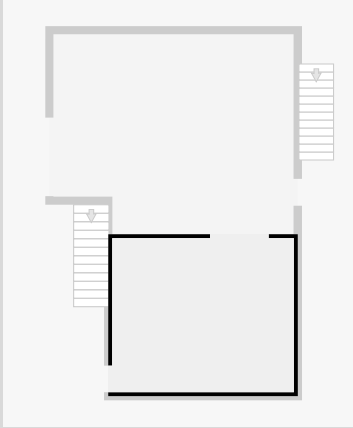

Garage

Width: 6.17 m
 Length: 7.41 m
 Area: 43.61 m²
 Perimeter: 27.16 m

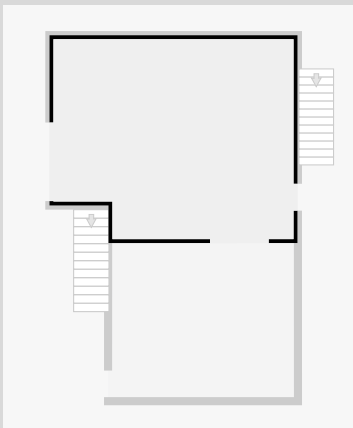

THIS FLOORPLAN IS PROVIDED WITHOUT WARRANTY OF ANY KIND. SENSOPIA DISCLAIMS ANY WARRANTY INCLUDING, WITHOUT LIMITATION, SATISFACTORY QUALITY OR ACCURACY OF DIMENSIONS.

6 Mercer Street

1st Floor

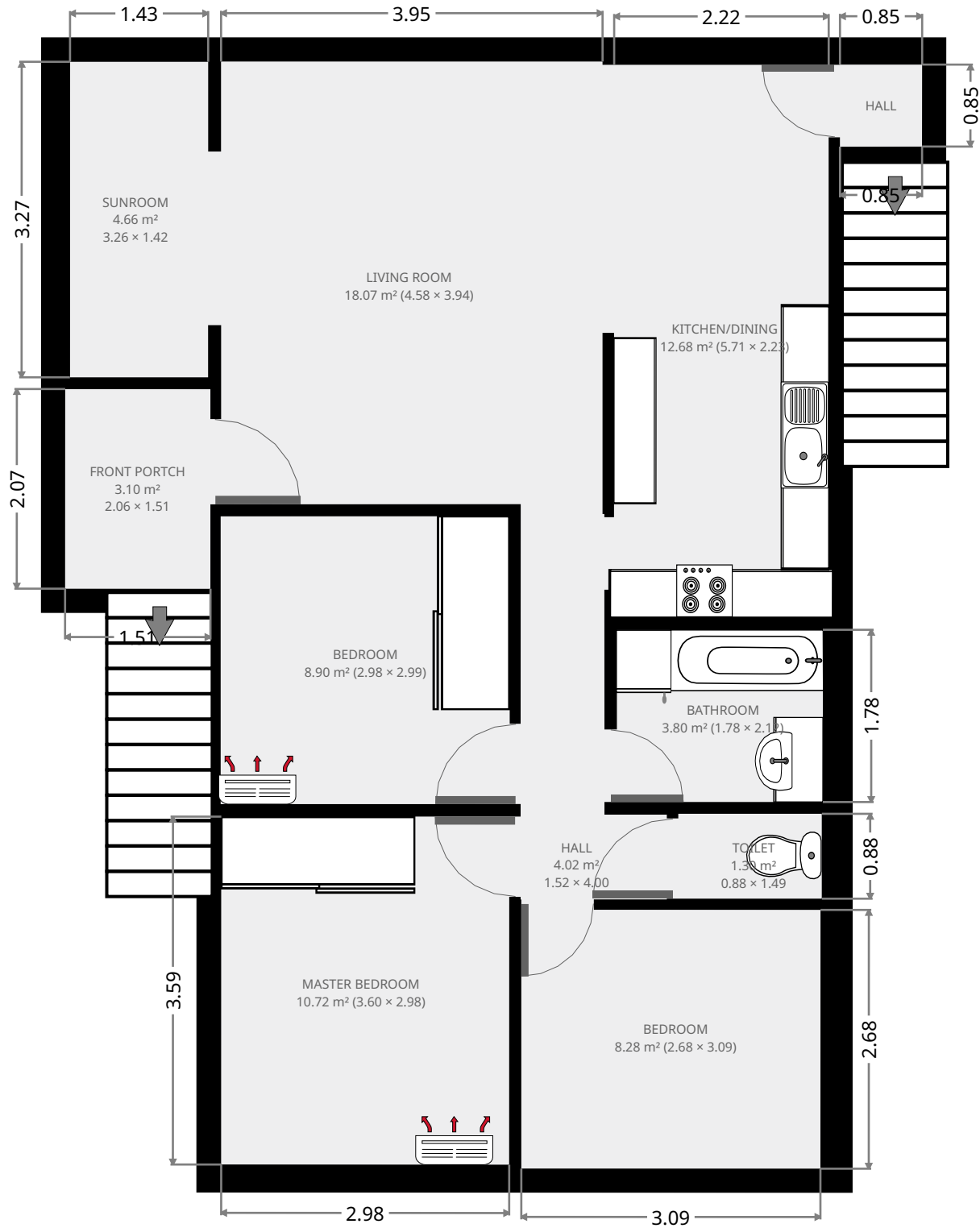

THIS FLOORPLAN IS PROVIDED WITHOUT WARRANTY OF ANY KIND. SENSOPIA DISCLAIMS ANY WARRANTY INCLUDING, WITHOUT LIMITATION, SATISFACTORY QUALITY OR ACCURACY OF DIMENSIONS.

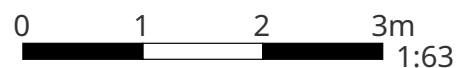

6 Mercer Street

Living Room

Width: 3.94 m
 Length: 4.58 m
 Area: 18.07 m²
 Perimeter: 17.05 m

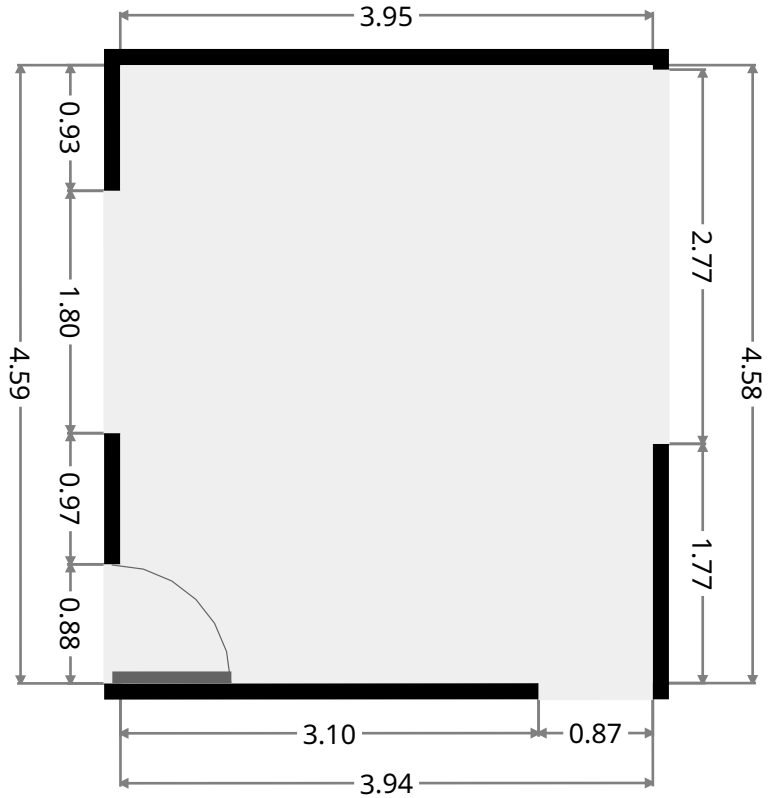
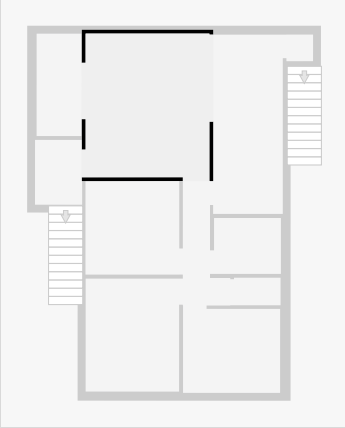

Sunroom

Width: 1.42 m
 Length: 3.26 m
 Area: 4.66 m²
 Perimeter: 9.39 m

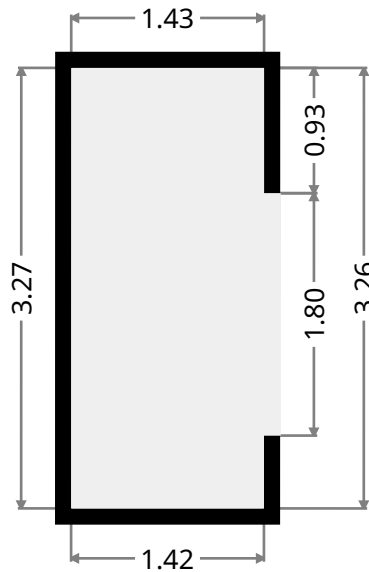
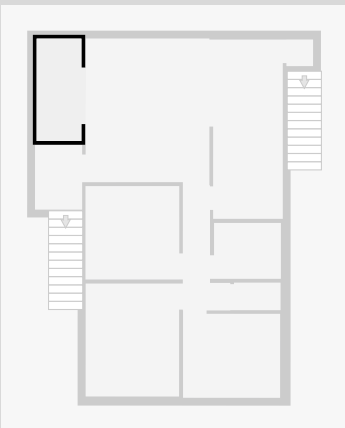

6 Mercer Street

Kitchen/Dining

Width: 2.23 m
Length: 5.71 m
Area: 12.68 m²
Perimeter: 15.87 m

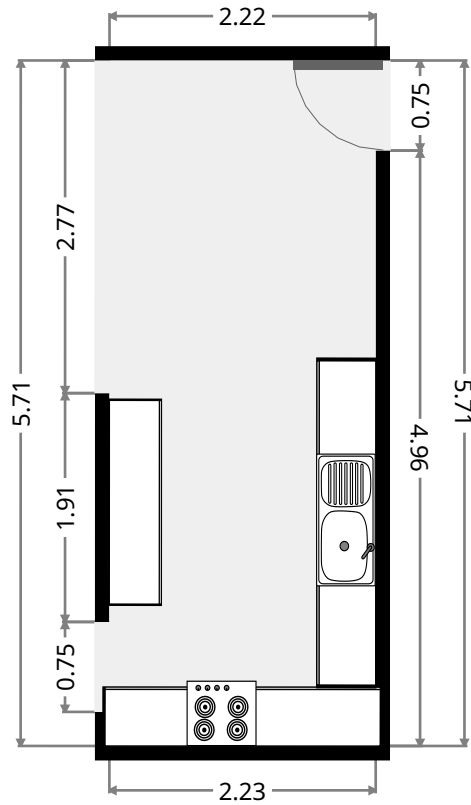
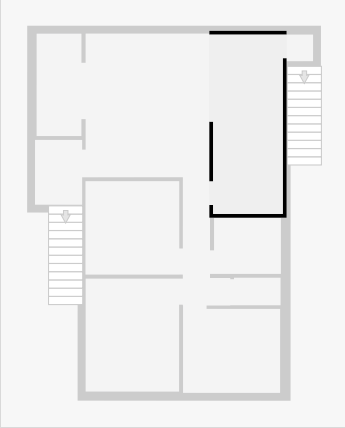

Hall

Width: 0.85 m
Length: 0.85 m
Area: 0.72 m²
Perimeter: 3.40 m

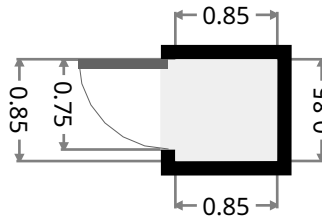
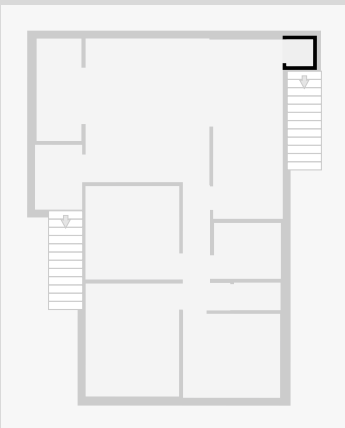

6 Mercer Street

Hall

Width: 1.52 m
 Length: 4.00 m
 Area: 4.02 m²
 Perimeter: 11.00 m

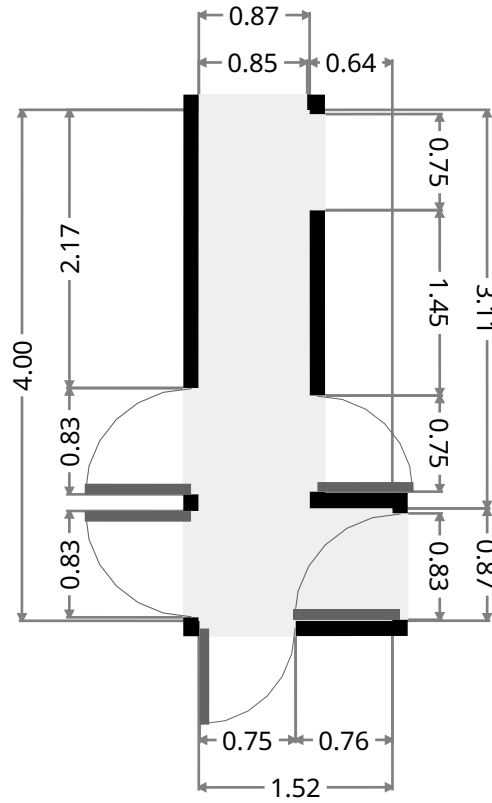
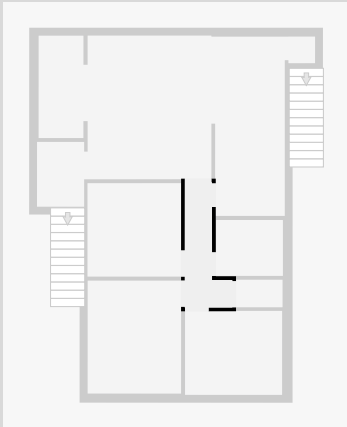

Bathroom

Width: 1.78 m
 Length: 2.12 m
 Area: 3.80 m²
 Perimeter: 7.82 m

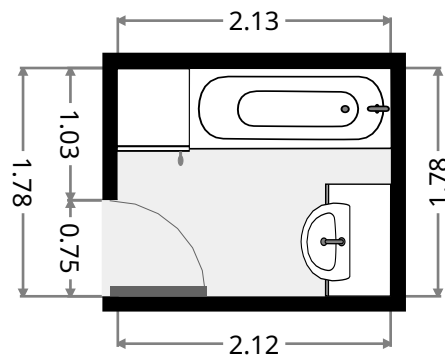
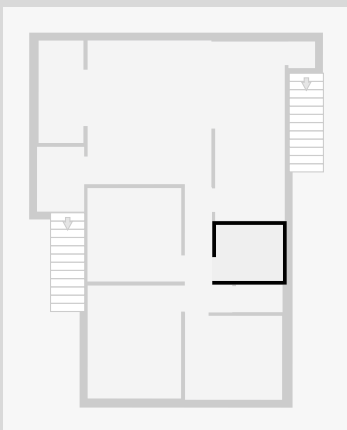

6 Mercer Street

Toilet

Width: 0.88 m
Length: 1.49 m
Area: 1.30 m²
Perimeter: 4.72 m

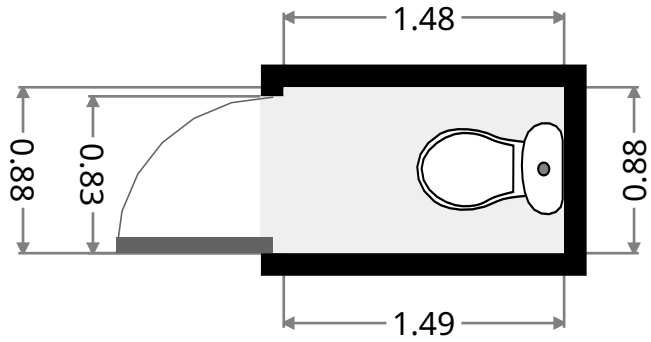
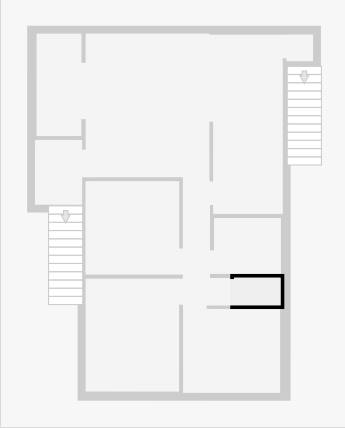

Bedroom

Width: 2.68 m
Length: 3.09 m
Area: 8.28 m²
Perimeter: 11.54 m

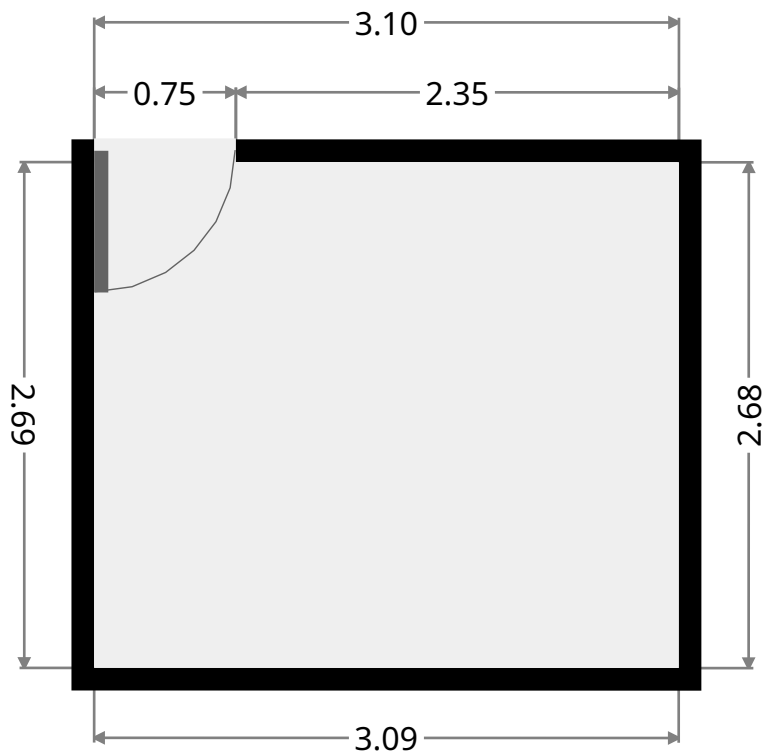
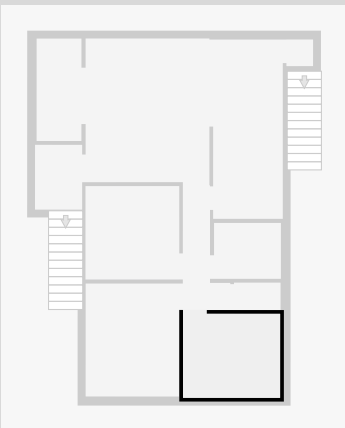

6 Mercer Street

Master Bedroom

Width: 2.98 m
 Length: 3.60 m
 Area: 10.72 m²
 Perimeter: 13.16 m

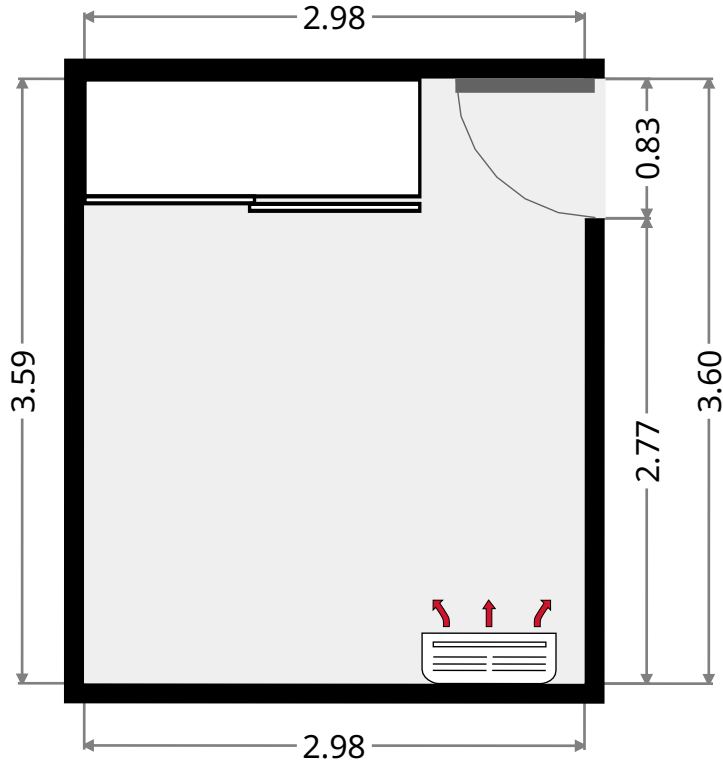
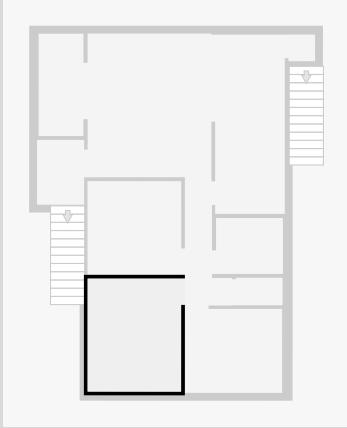

Bedroom

Width: 2.98 m
 Length: 2.99 m
 Area: 8.90 m²
 Perimeter: 11.94 m

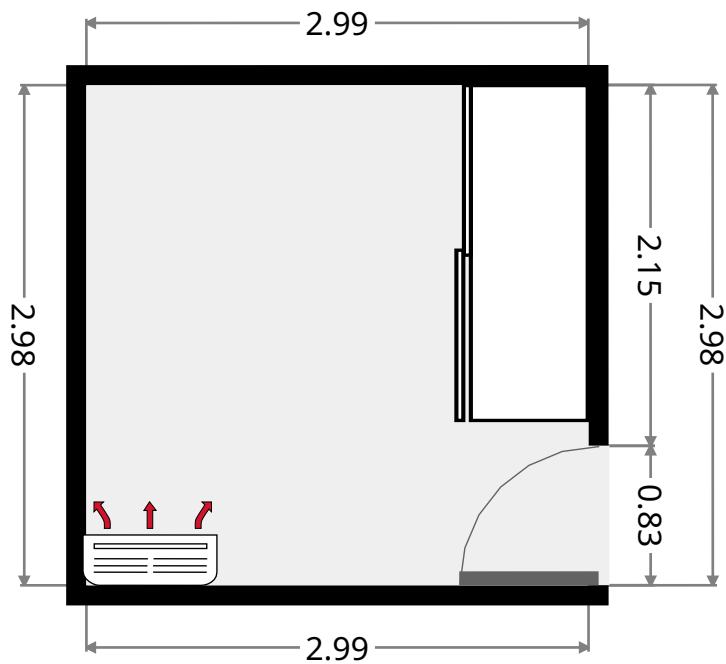
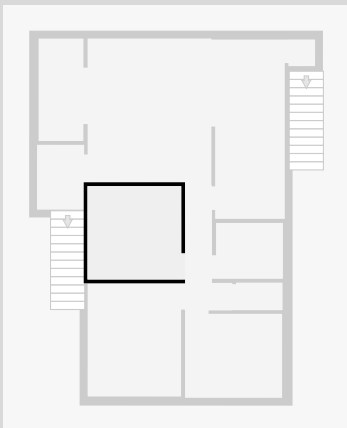

THIS FLOORPLAN IS PROVIDED WITHOUT WARRANTY OF ANY KIND. SENSOPIA DISCLAIMS ANY WARRANTY INCLUDING, WITHOUT LIMITATION, SATISFACTORY QUALITY OR ACCURACY OF DIMENSIONS.

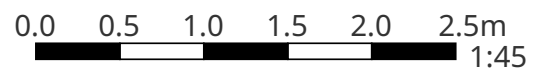

6 Mercer Street

Front Portch

Width: 1.51 m
Length: 2.06 m
Area: 3.10 m²
Perimeter: 7.14 m

