

6 Laver Street

Created on
2021-07-13

Floors
2

▼ Ground Floor

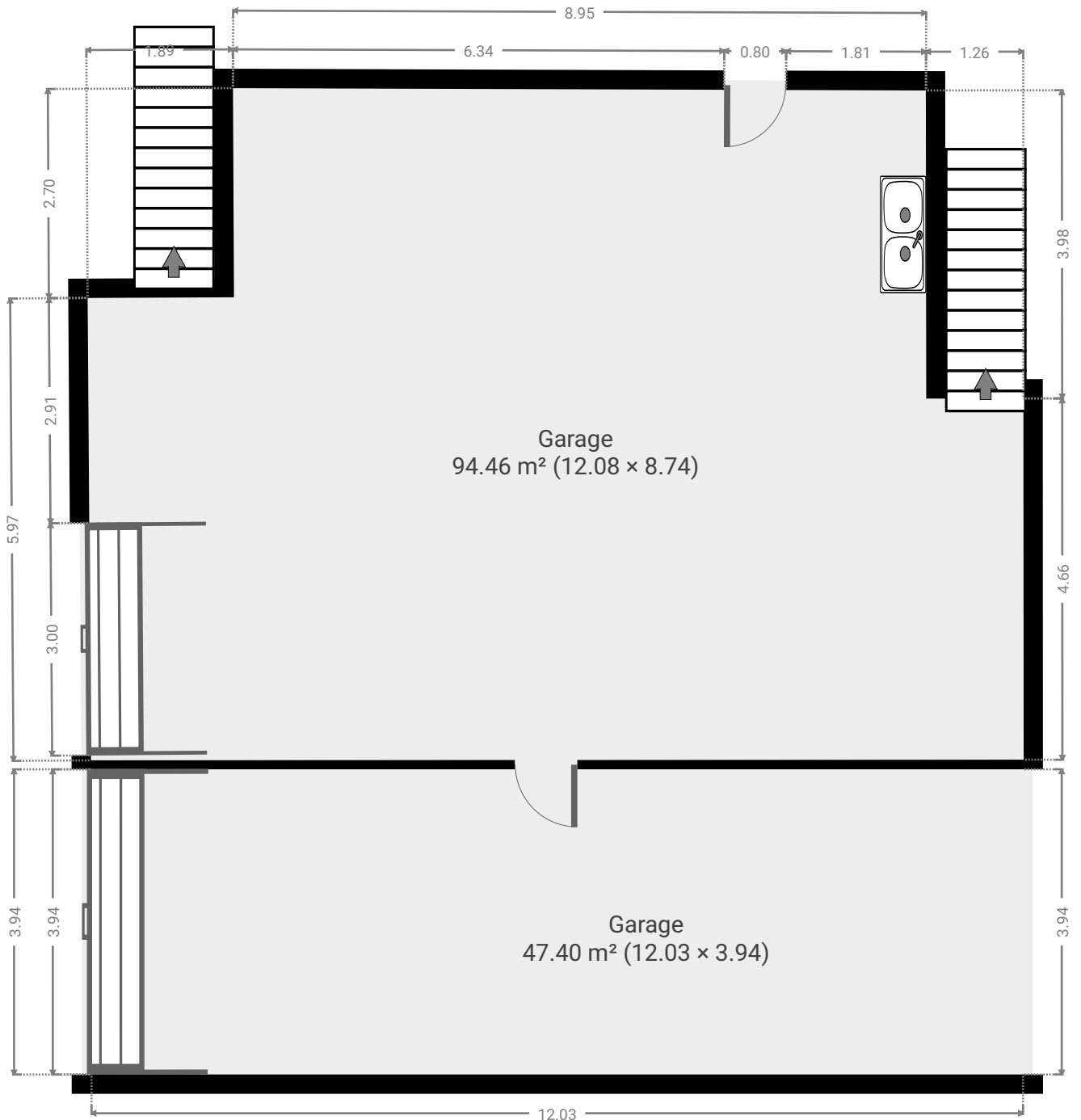

▼ Garage
Ground Floor

WIDTH: 8.69 m • LENGTH: 12.19 m
AREA: 94.46 m² • PERIMETER: 41.45 m

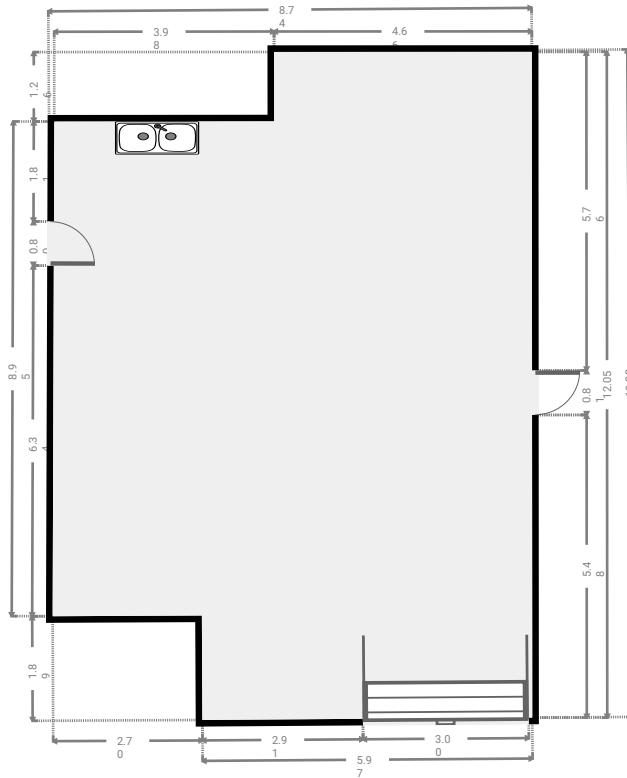
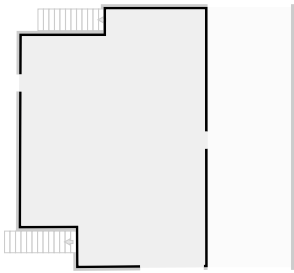

▼ Garage
Ground Floor

WIDTH: 3.94 m • LENGTH: 12.03 m
AREA: 47.40 m² • PERIMETER: 31.94 m

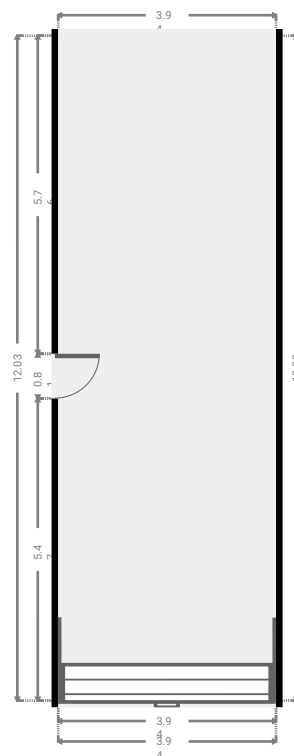
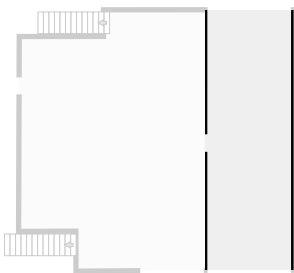

▼ 1st Floor

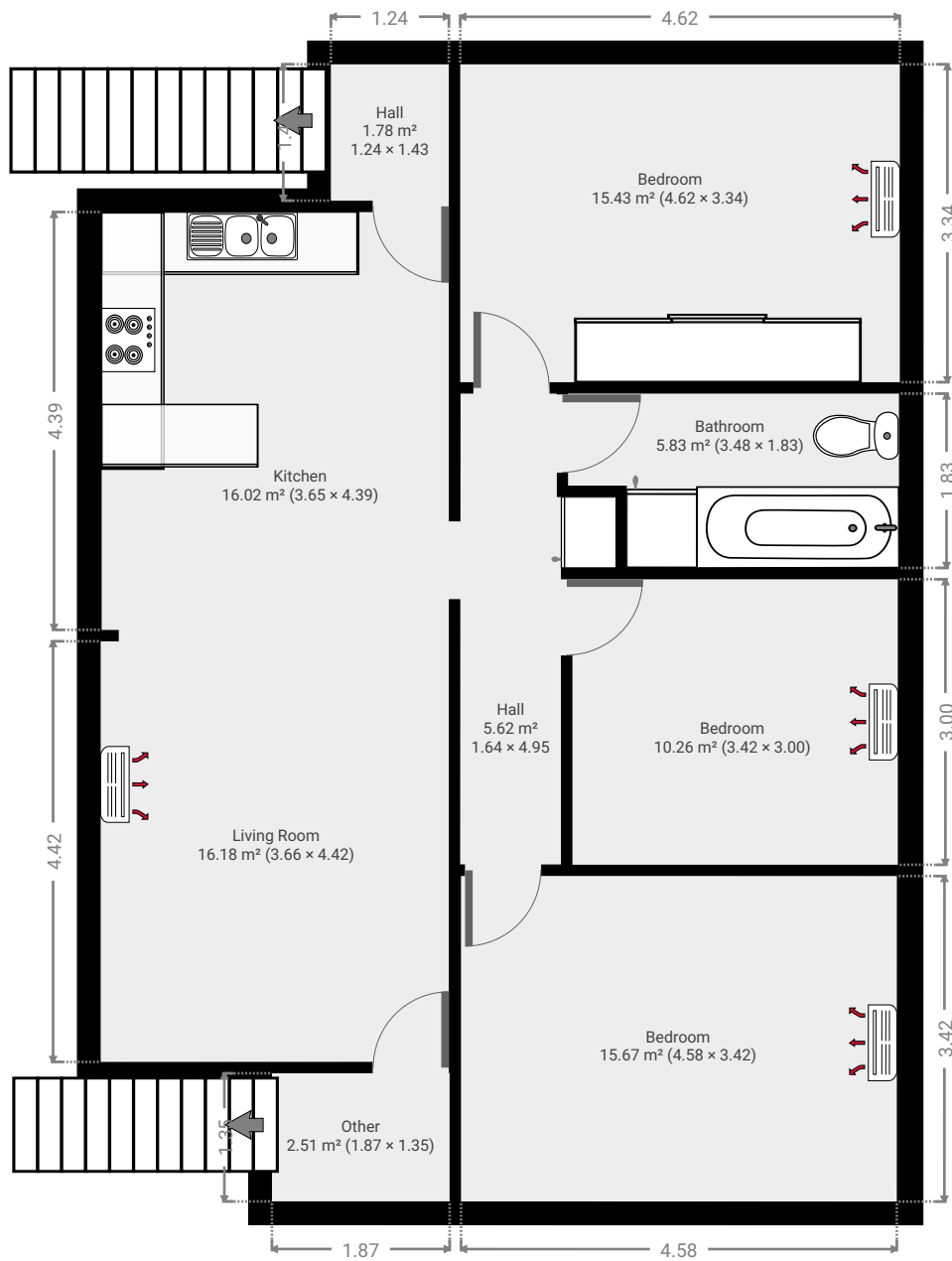

▼ Living Room
1st Floor

WIDTH: 3.66 m • LENGTH: 4.42 m
AREA: 16.18 m² • PERIMETER: 16.16 m

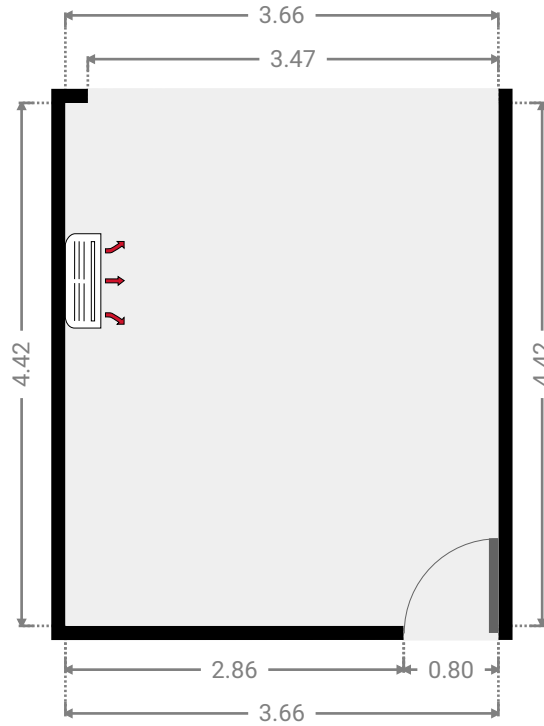
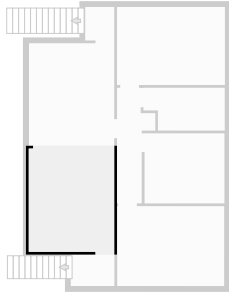

▼ Kitchen
1st Floor

WIDTH: 3.65 m • LENGTH: 4.39 m
AREA: 16.02 m² • PERIMETER: 16.08 m

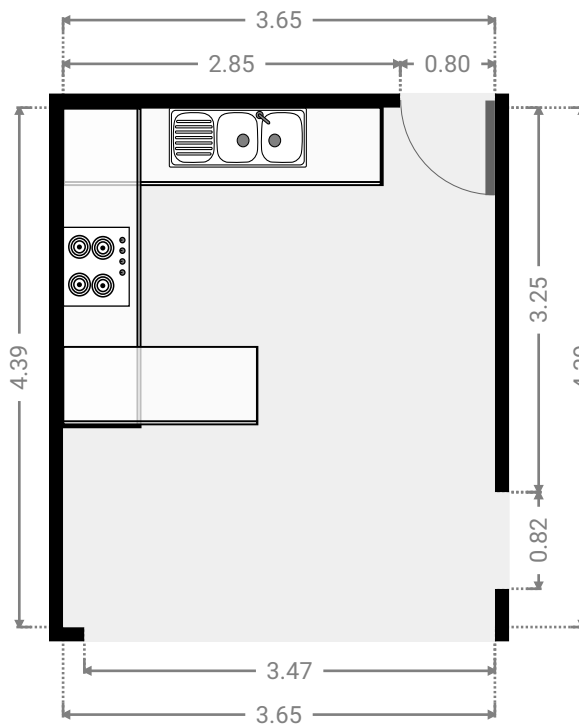
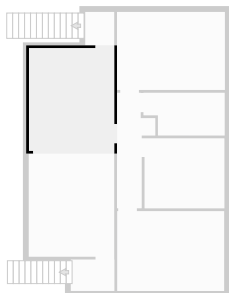

▼ Hall
1st Floor

WIDTH: 1.64 m • LENGTH: 4.95 m
AREA: 5.62 m² • PERIMETER: 13.17 m

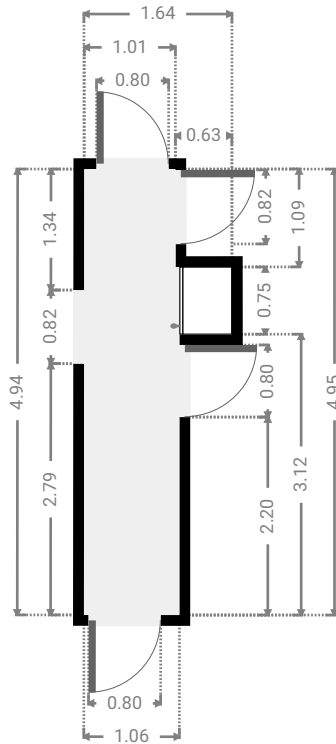
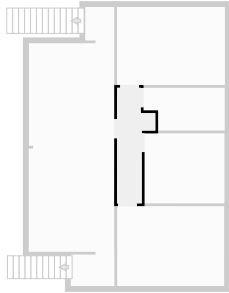

▼ Bedroom
1st Floor

WIDTH: 4.58 m • LENGTH: 3.42 m
AREA: 15.67 m² • PERIMETER: 16.00 m

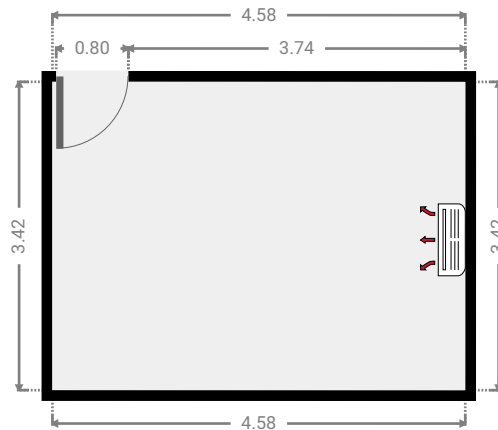
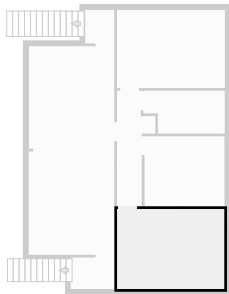

▼ **Bedroom**
1st Floor

WIDTH: 3.42 m • LENGTH: 3.00 m
AREA: 10.26 m² • PERIMETER: 12.84 m

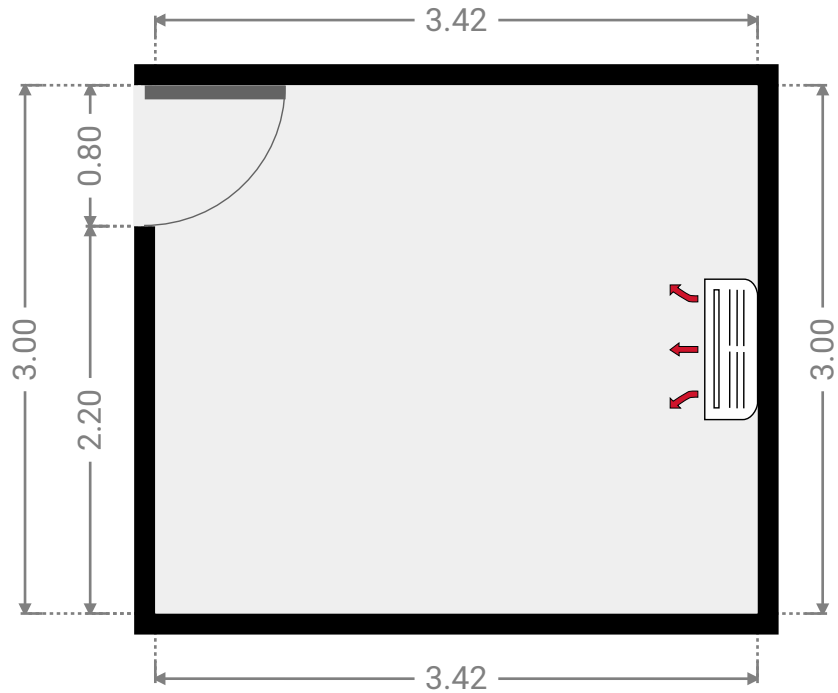
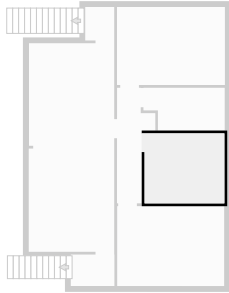

▼ **Bathroom**
1st Floor

WIDTH: 3.48 m • LENGTH: 1.83 m
AREA: 5.83 m² • PERIMETER: 10.62 m

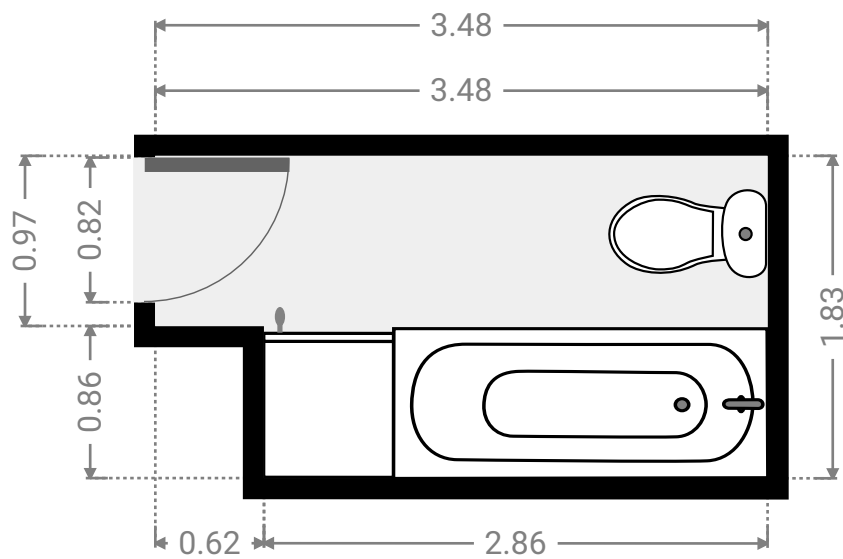
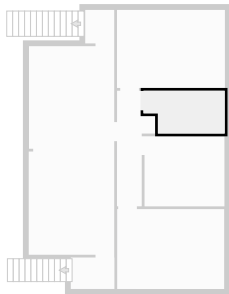

▼ **Bedroom**
1st Floor

WIDTH: 4.62 m • LENGTH: 3.34 m
AREA: 15.43 m² • PERIMETER: 15.92 m

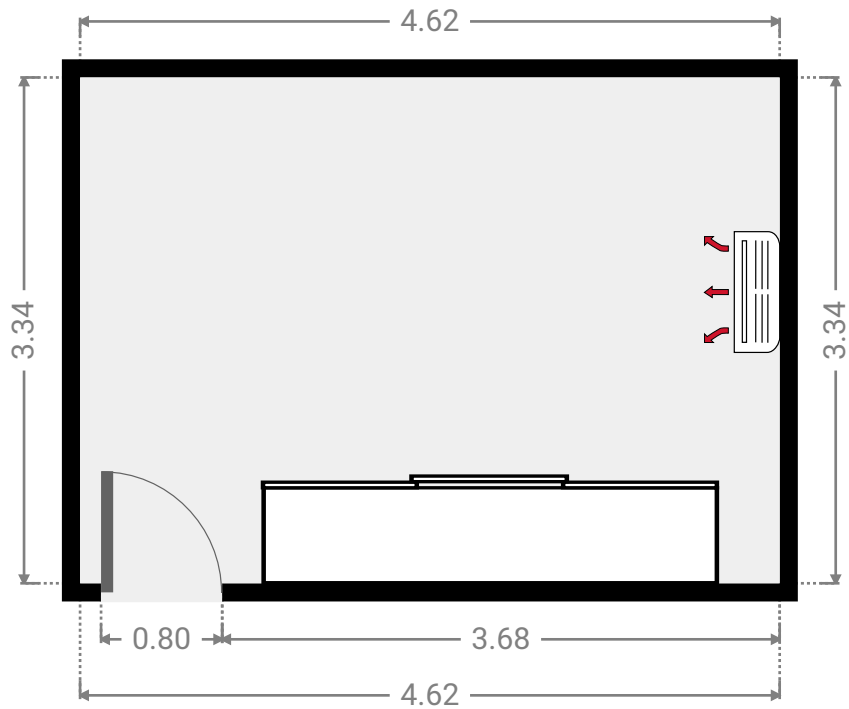
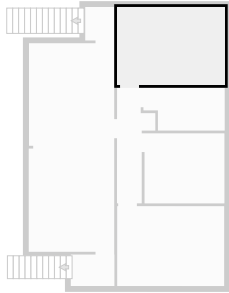

▼ **Hall**
1st Floor

WIDTH: 1.24 m • LENGTH: 1.43 m
AREA: 1.78 m² • PERIMETER: 5.35 m

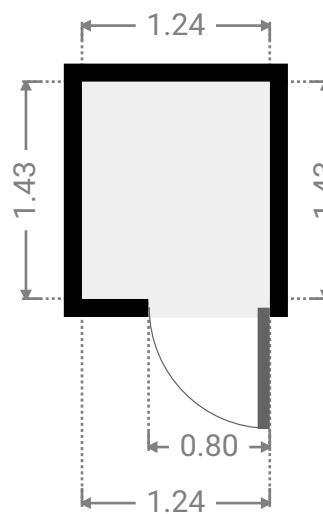
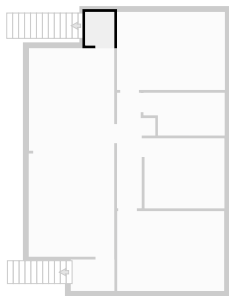

▼ Other
1st Floor

WIDTH: 1.87 m • LENGTH: 1.35 m
AREA: 2.51 m² • PERIMETER: 6.43 m

