

6 Knutsford Street

Created on
2021-07-15

Floors
2

▼ Ground Floor

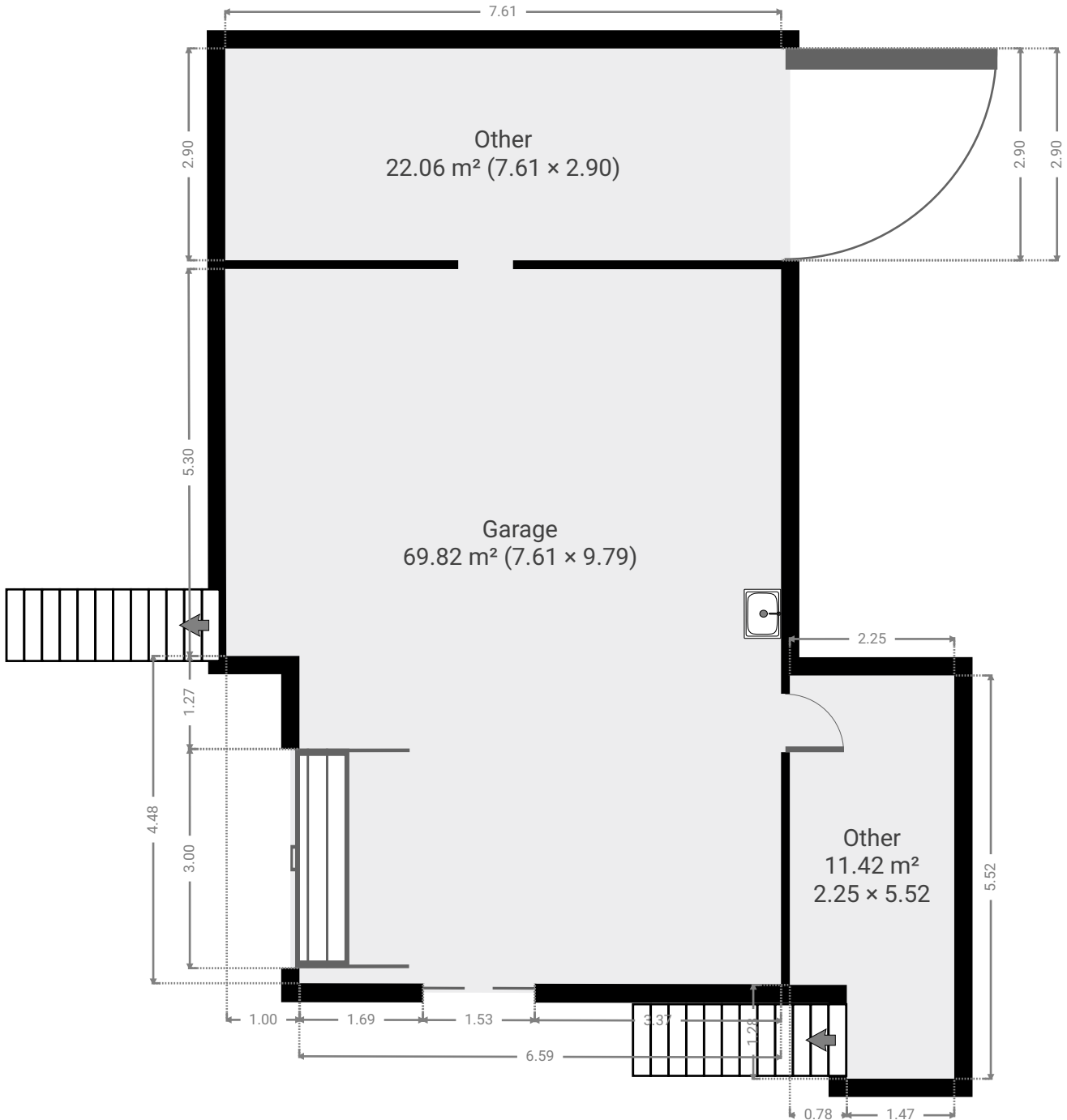

▼ **Garage**
Ground Floor

WIDTH: 9.81 m • LENGTH: 7.61 m
AREA: 69.82 m² • PERIMETER: 34.77 m

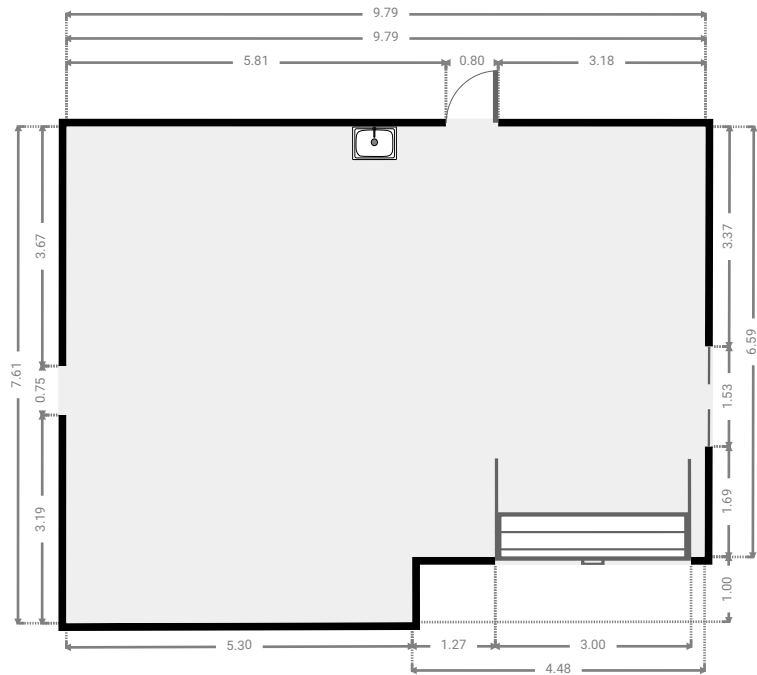
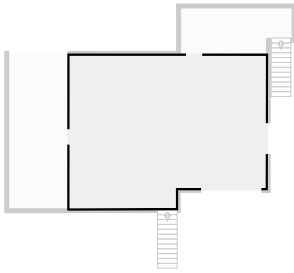

▼ **Other**
Ground Floor

WIDTH: 2.90 m • LENGTH: 7.61 m
AREA: 22.06 m² • PERIMETER: 21.01 m

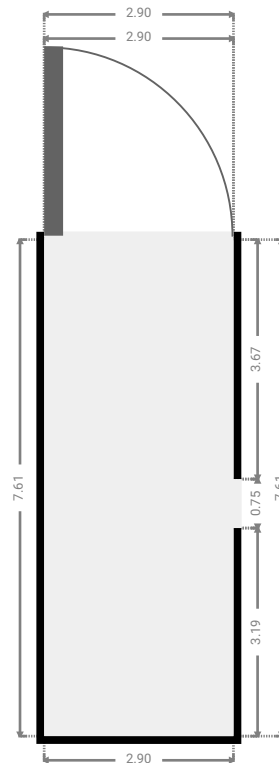
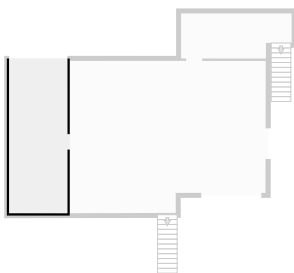

▼ Other
Ground Floor

WIDTH: 5.52 m • LENGTH: 2.25 m
AREA: 11.42 m² • PERIMETER: 15.54 m

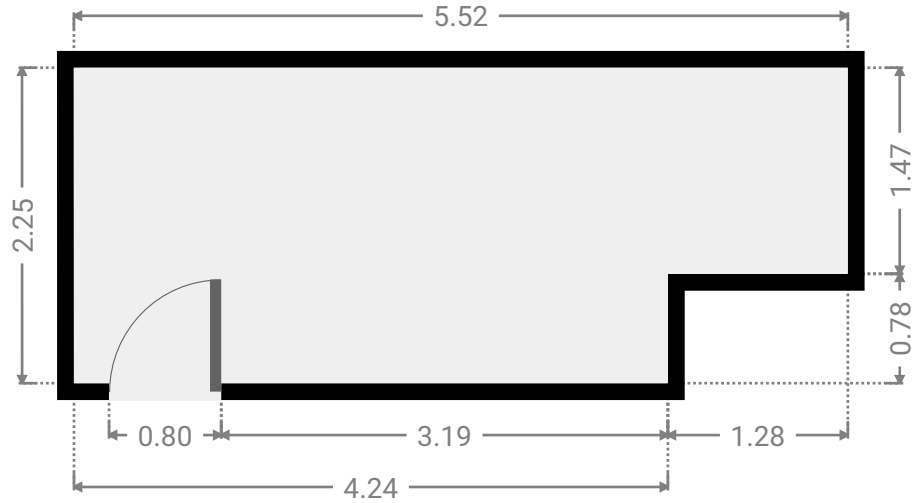
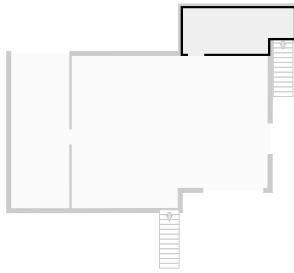

▼ 1st Floor

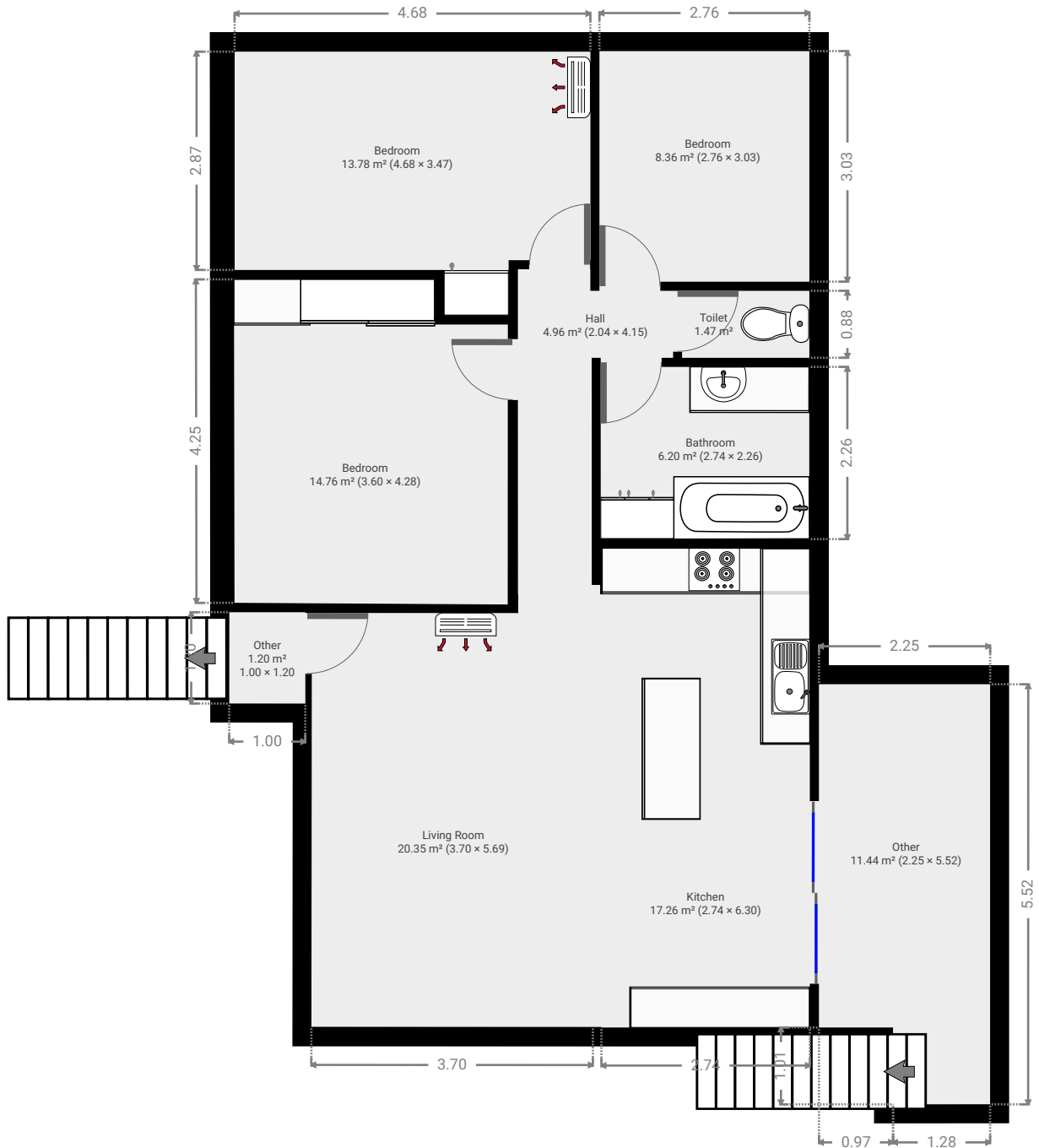

▼ **Living Room**
1st Floor

WIDTH: 5.69 m • LENGTH: 3.70 m
AREA: 20.35 m² • PERIMETER: 18.77 m

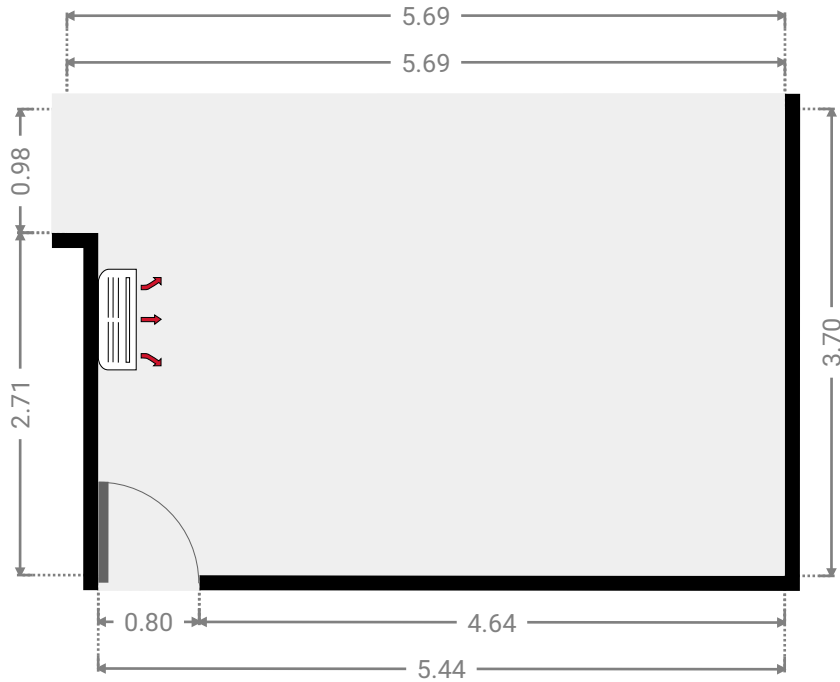
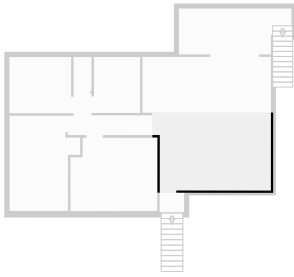

▼ **Kitchen**
1st Floor

WIDTH: 6.30 m • LENGTH: 2.74 m
AREA: 17.26 m² • PERIMETER: 18.08 m

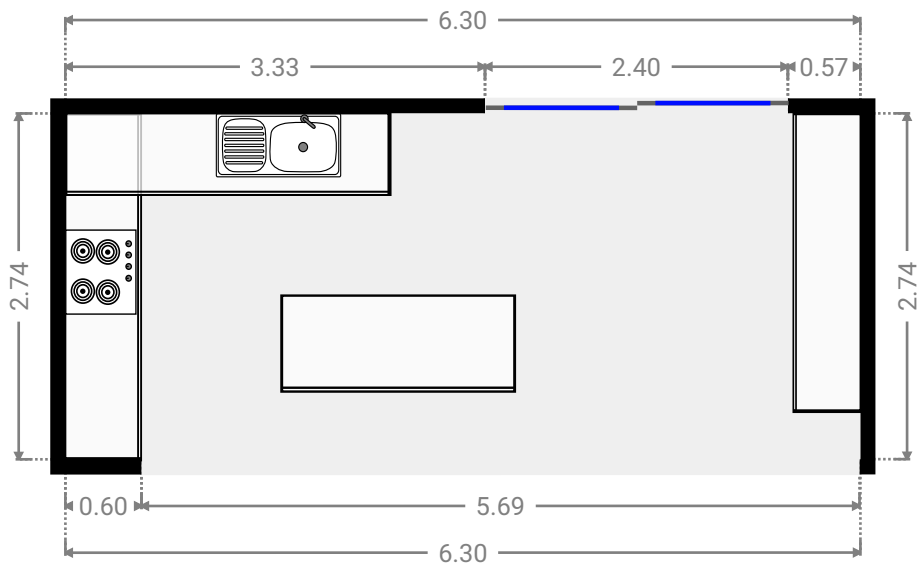
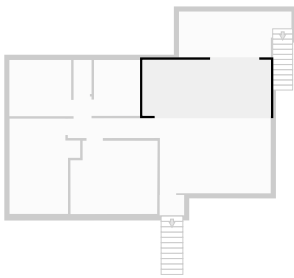

▼ Hall
1st Floor

WIDTH: 4.15 m • LENGTH: 2.04 m
AREA: 4.96 m² • PERIMETER: 12.38 m

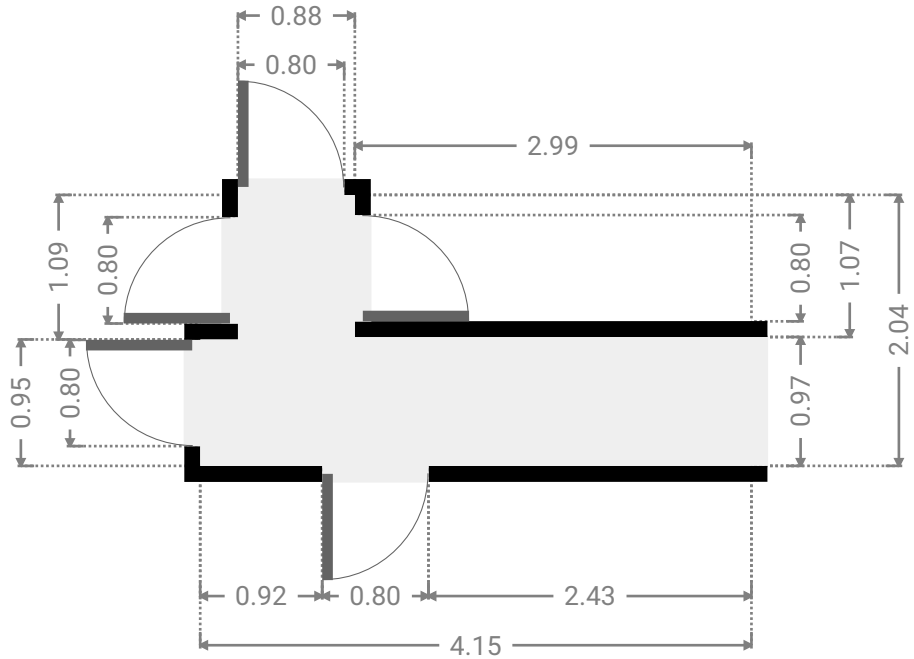
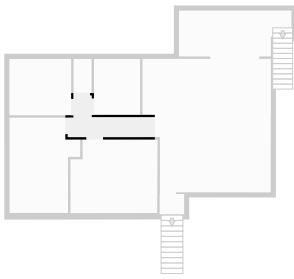

▼ Bedroom
1st Floor

WIDTH: 4.28 m • LENGTH: 3.60 m
AREA: 14.76 m² • PERIMETER: 15.72 m

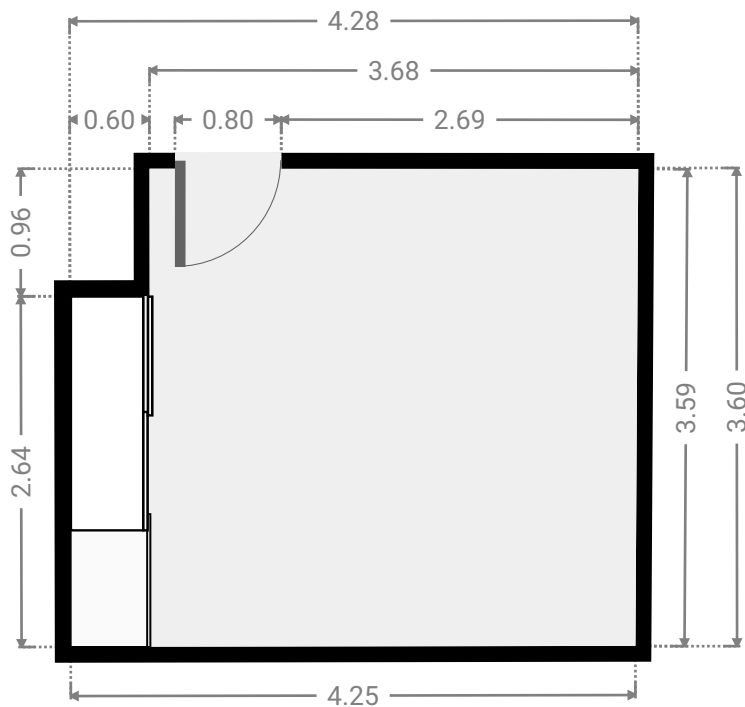
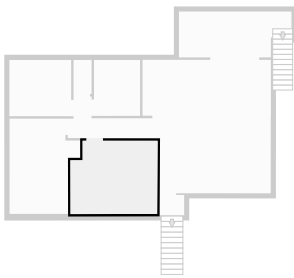

▼ **Bedroom**
1st Floor

WIDTH: 3.47 m • LENGTH: 4.68 m
AREA: 13.78 m² • PERIMETER: 16.28 m

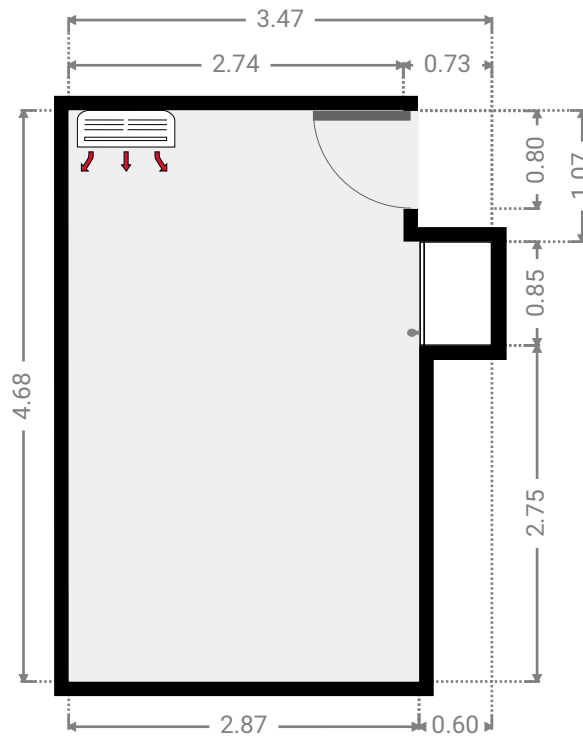
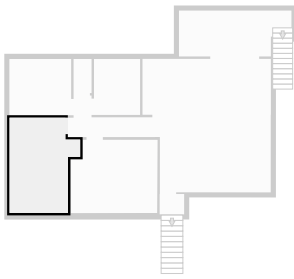

▼ **Bedroom**
1st Floor

WIDTH: 3.03 m • LENGTH: 2.76 m
AREA: 8.36 m² • PERIMETER: 11.58 m

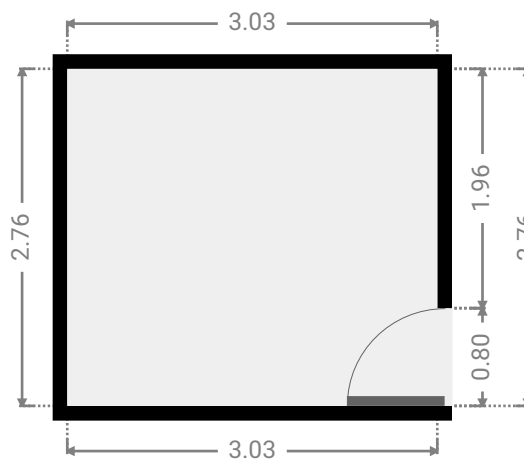
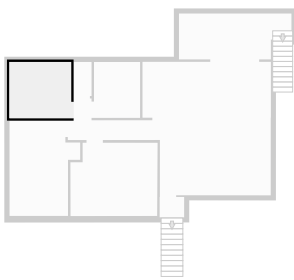

▼ **Toilet**
1st Floor

WIDTH: 0.88 m • LENGTH: 1.67 m
AREA: 1.47 m² • PERIMETER: 5.11 m

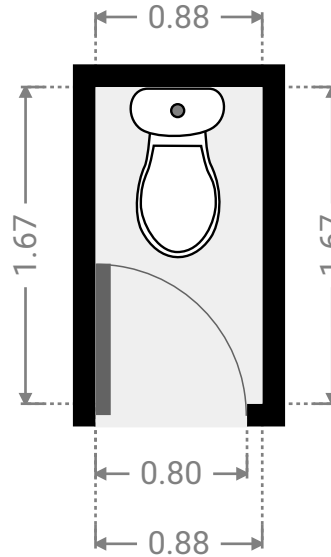
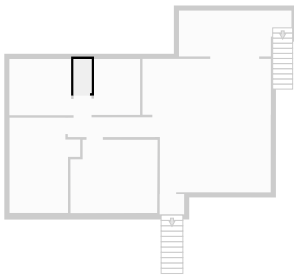

▼ **Bathroom**
1st Floor

WIDTH: 2.26 m • LENGTH: 2.74 m
AREA: 6.20 m² • PERIMETER: 10.01 m

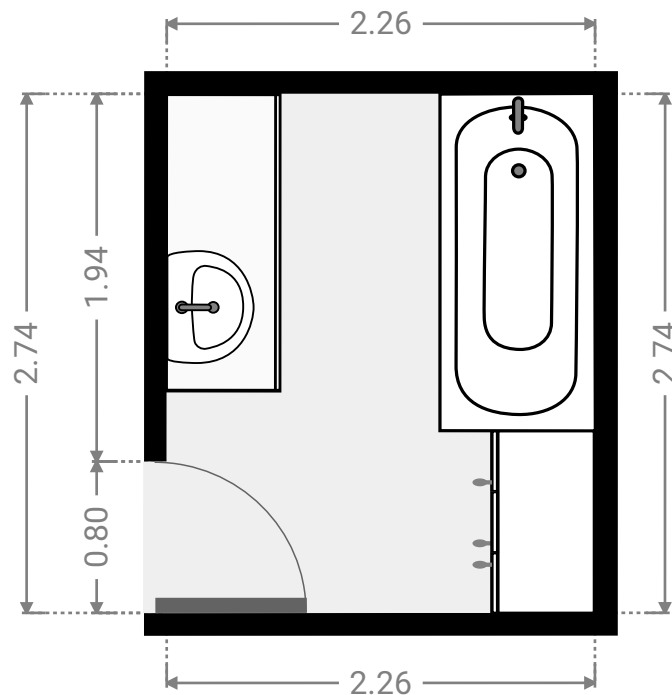
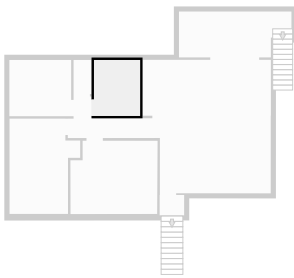

▼ Other
1st Floor

WIDTH: 5.52 m • LENGTH: 2.25 m
AREA: 11.44 m² • PERIMETER: 15.54 m

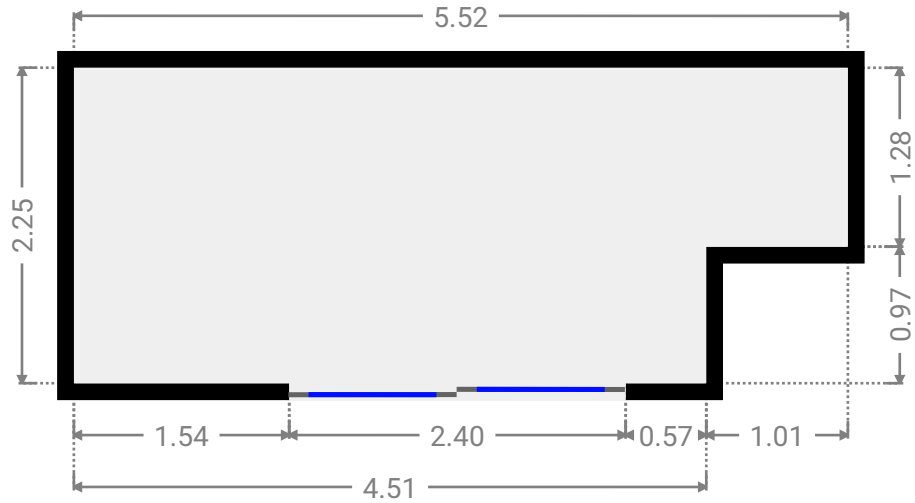
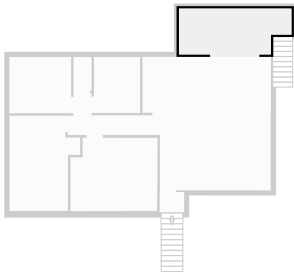

▼ Other
1st Floor

WIDTH: 1.20 m • LENGTH: 1.00 m
AREA: 1.20 m² • PERIMETER: 4.40 m

