

6 Broadhurst Drive

Created on
2021-03-30

Floors
1

▼ Ground Floor

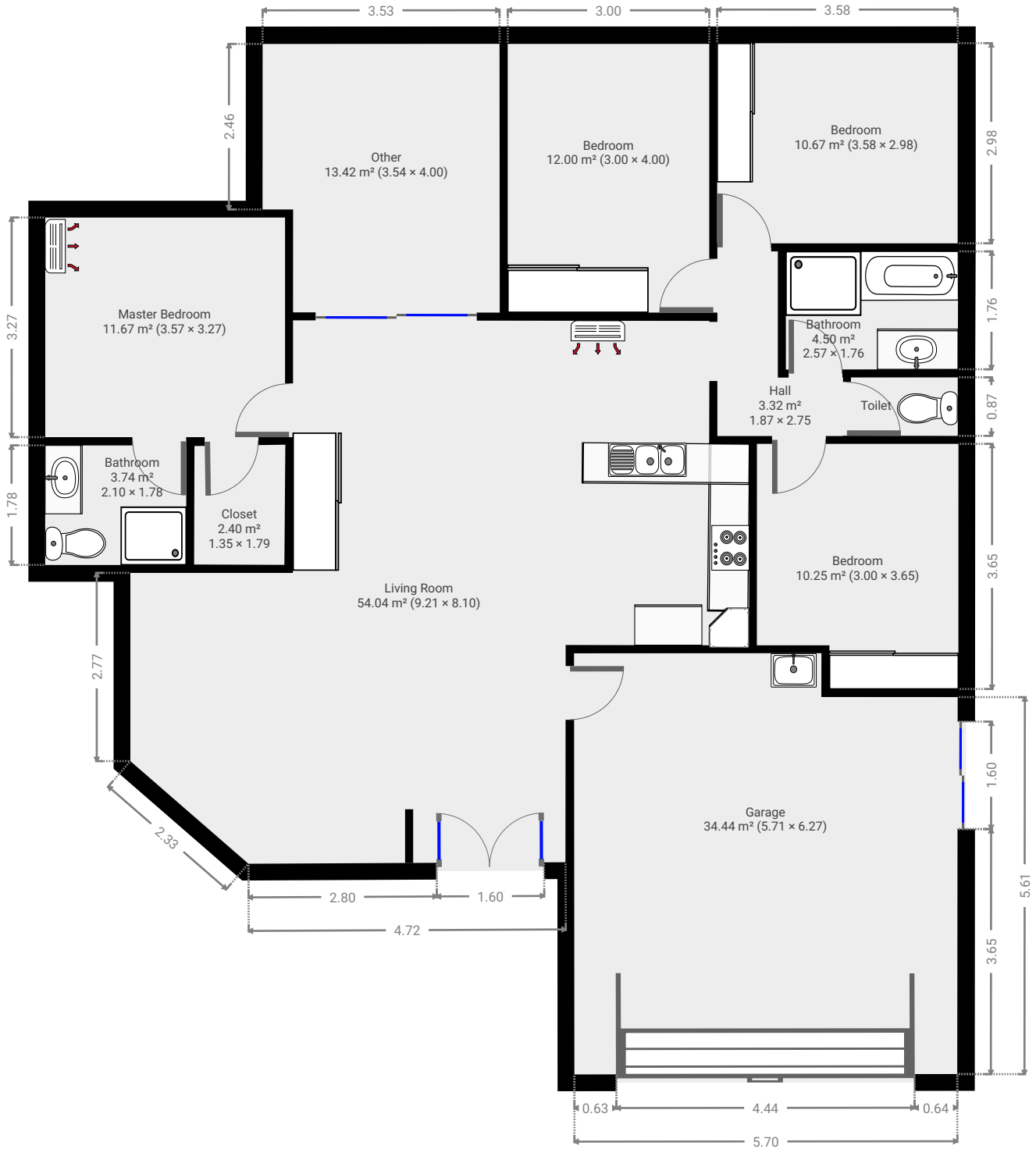

▼ Living Room
Ground Floor

WIDTH: 9.21 m • LENGTH: 8.10 m
AREA: 54.04 m² • PERIMETER: 33.63 m

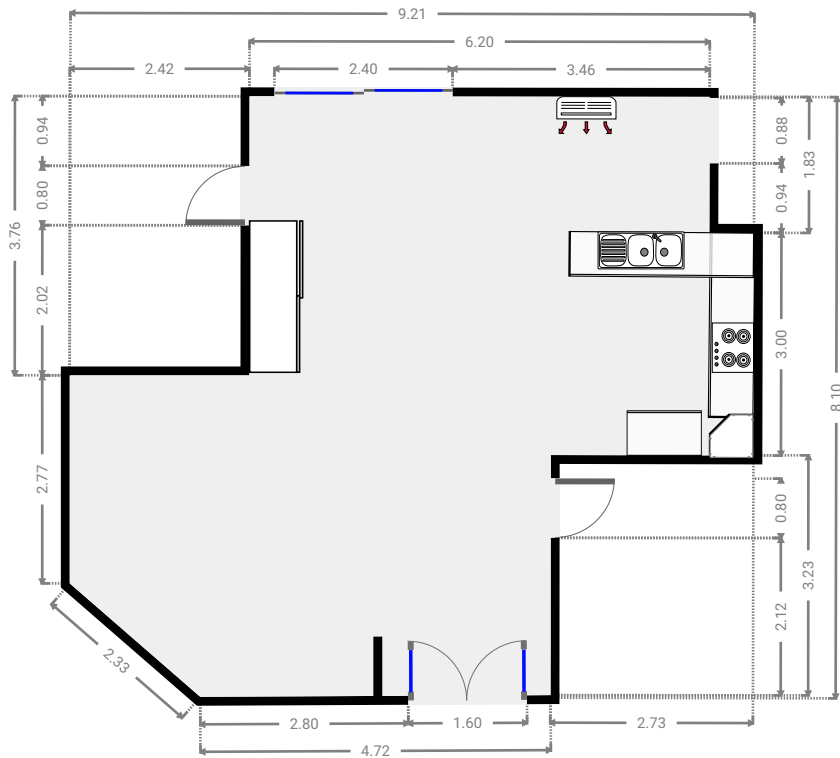
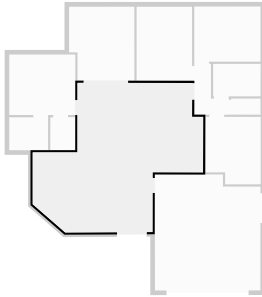

▼ Master Bedroom
Ground Floor

WIDTH: 3.57 m • LENGTH: 3.27 m
AREA: 11.67 m² • PERIMETER: 13.68 m

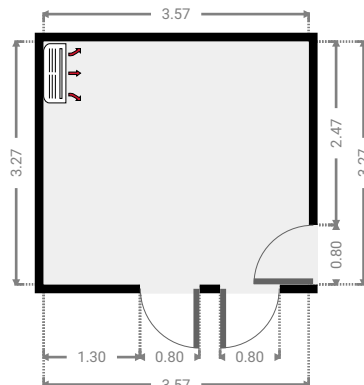
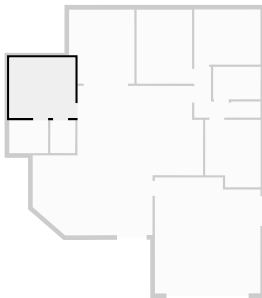

▼ Bathroom
Ground Floor

WIDTH: 2.10 m • LENGTH: 1.78 m
AREA: 3.74 m² • PERIMETER: 7.76 m

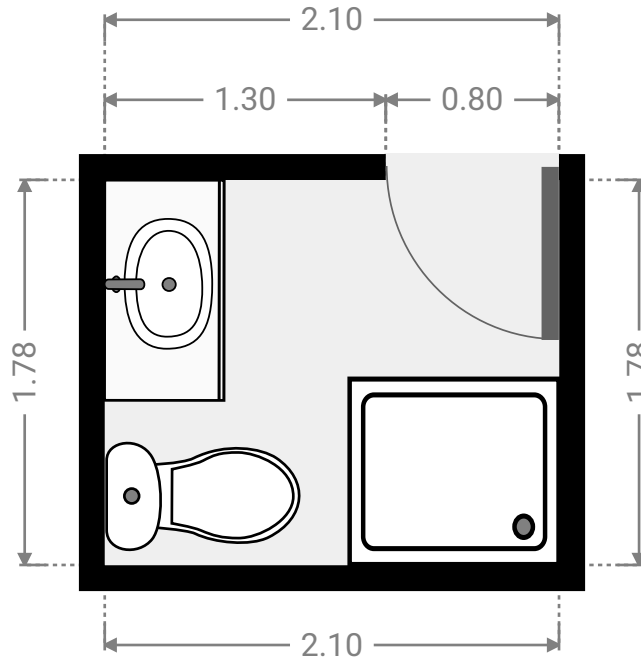
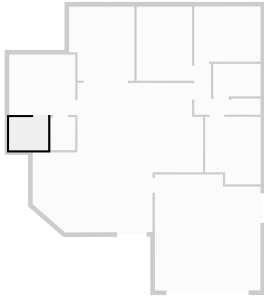

▼ Closet
Ground Floor

WIDTH: 1.35 m • LENGTH: 1.79 m
AREA: 2.40 m² • PERIMETER: 6.25 m

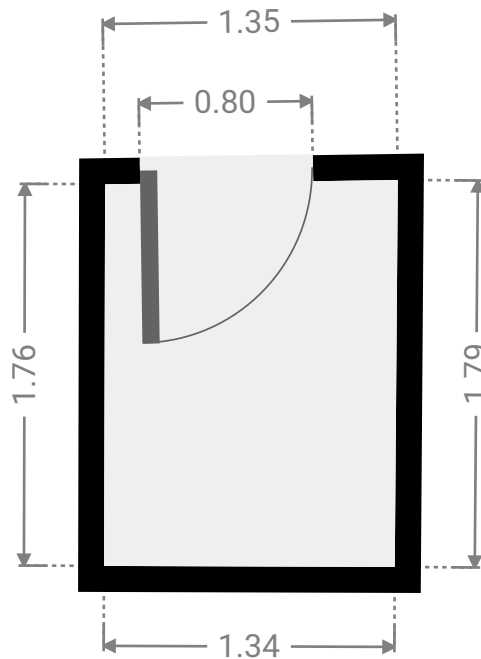
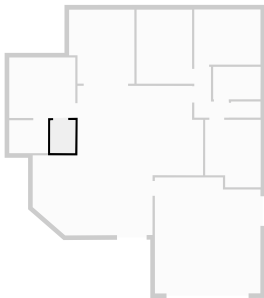

▼ **Hall**
Ground Floor

WIDTH: 1.87 m • LENGTH: 2.75 m
AREA: 3.32 m² • PERIMETER: 9.24 m

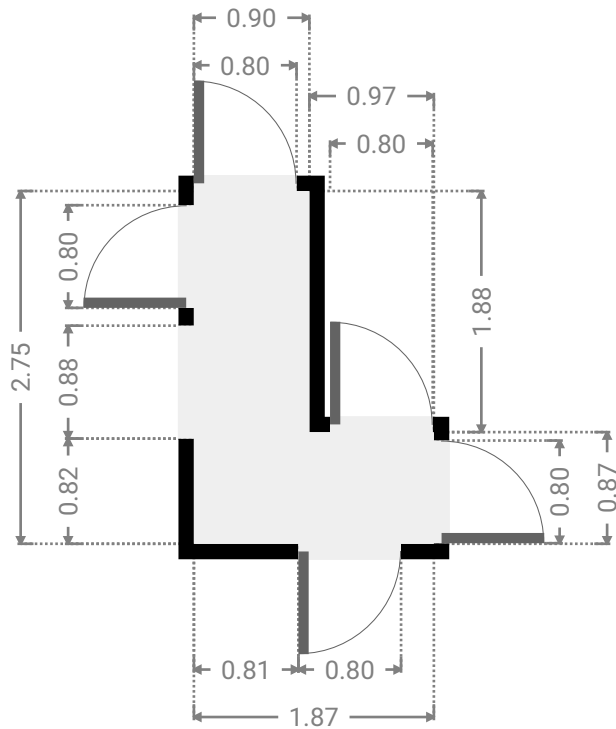
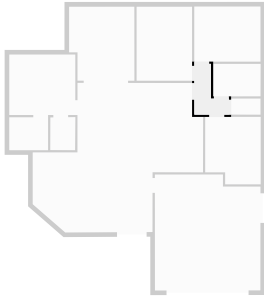

▼ **Bedroom**
Ground Floor

WIDTH: 3.00 m • LENGTH: 4.00 m
AREA: 12.00 m² • PERIMETER: 14.00 m

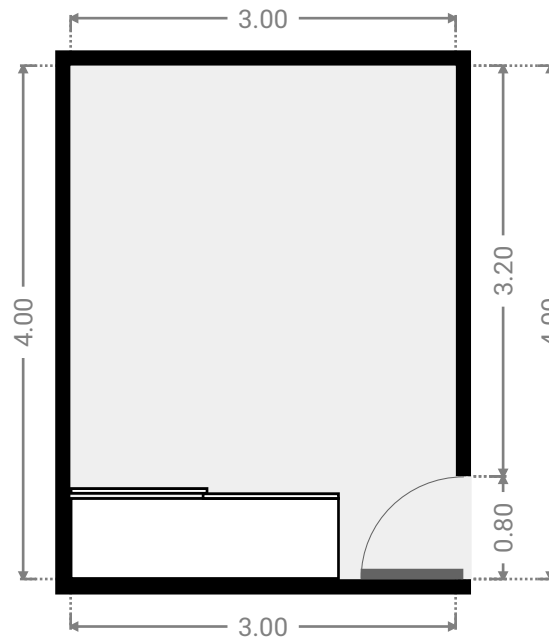
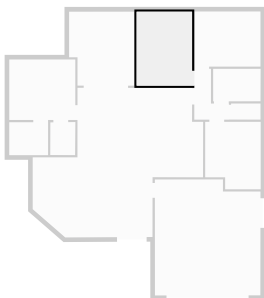

▼ **Bedroom**
Ground Floor

WIDTH: 3.58 m • LENGTH: 2.98 m
AREA: 10.67 m² • PERIMETER: 13.12 m

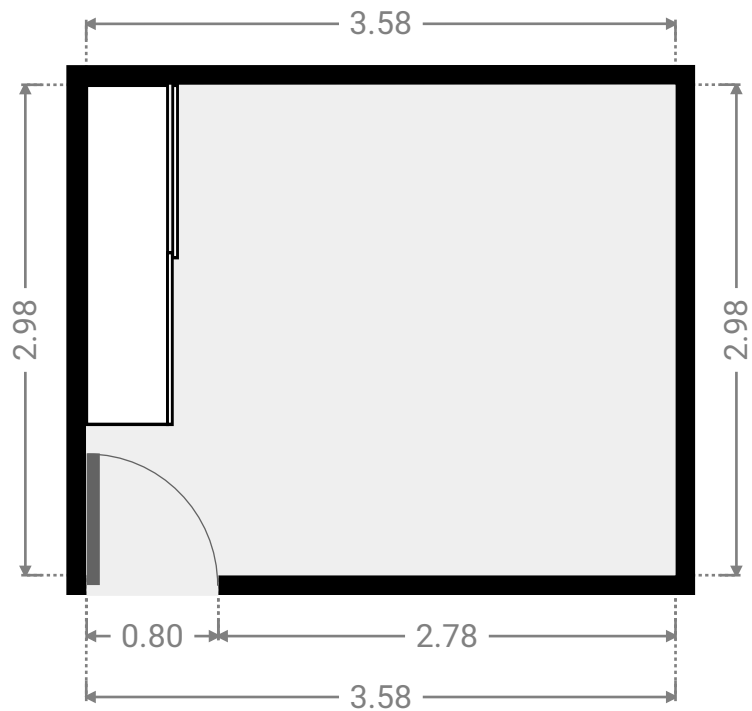
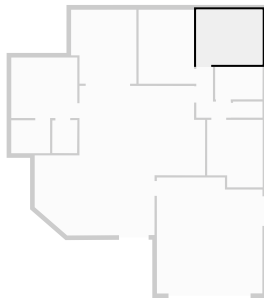

▼ **Bathroom**
Ground Floor

WIDTH: 2.57 m • LENGTH: 1.76 m
AREA: 4.50 m² • PERIMETER: 8.64 m

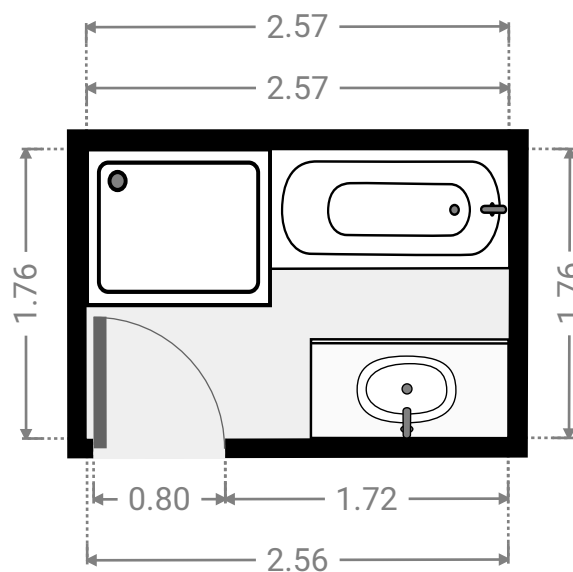
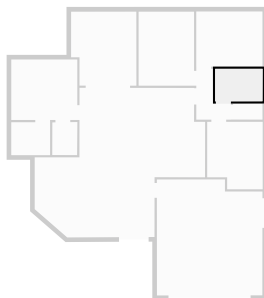

▼ Toilet
Ground Floor

WIDTH: 1.59 m • LENGTH: 0.87 m
AREA: 1.38 m² • PERIMETER: 4.92 m

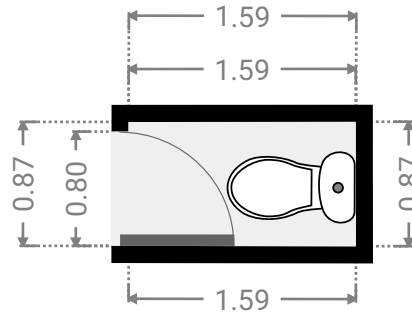
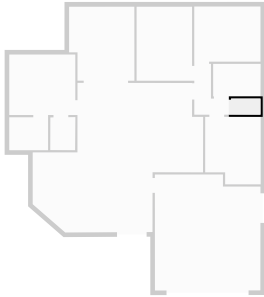

▼ Bedroom
Ground Floor

WIDTH: 3.00 m • LENGTH: 3.65 m
AREA: 10.25 m² • PERIMETER: 13.30 m

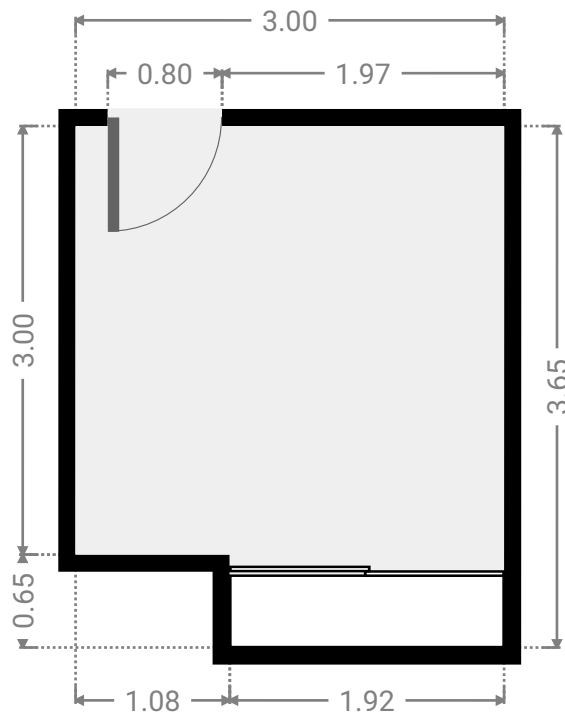
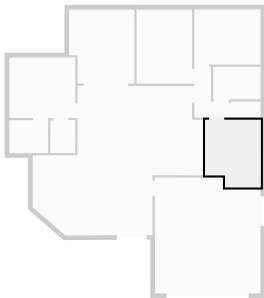

▼ **Garage**
Ground Floor

WIDTH: 5.71 m • LENGTH: 6.27 m
AREA: 34.44 m² • PERIMETER: 23.95 m

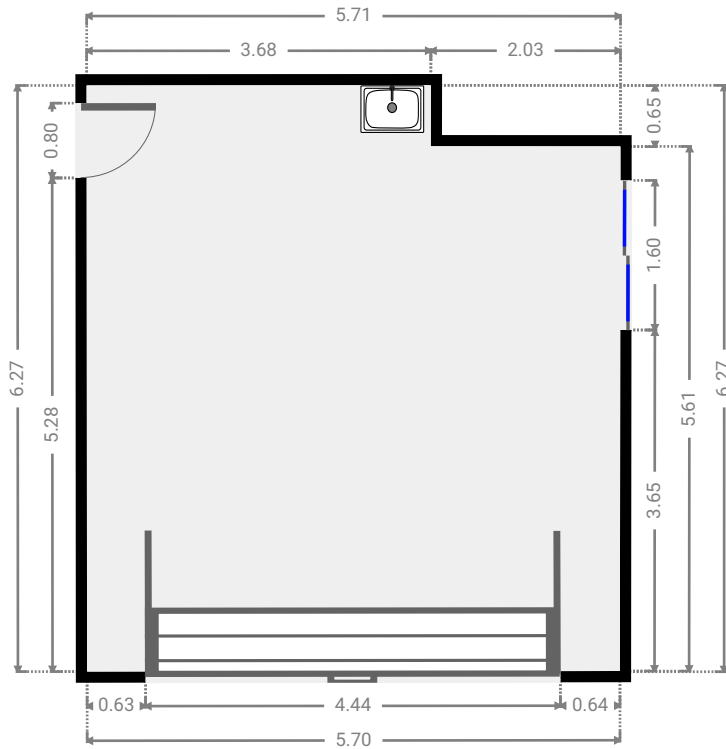
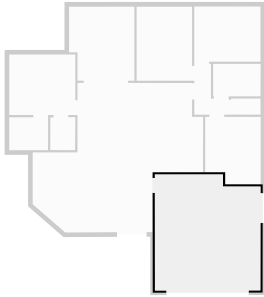

▼ **Other**
Ground Floor

WIDTH: 3.54 m • LENGTH: 4.00 m
AREA: 13.42 m² • PERIMETER: 15.06 m

