

6 Barry Street

SUBMITTED BY
Ray White Rockhampton Casey
stockers@cqoz.com

CREATED ON
2021-05-31

Floors
2

▼ Ground Floor

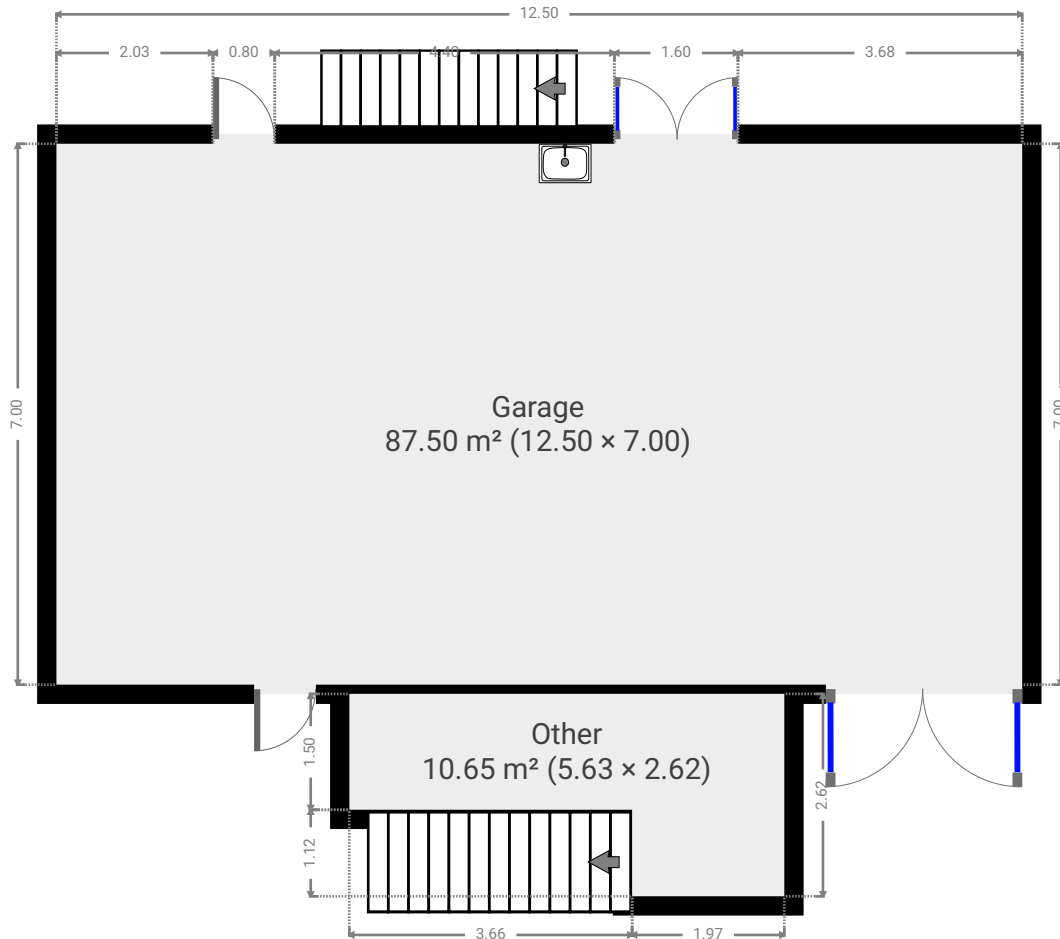
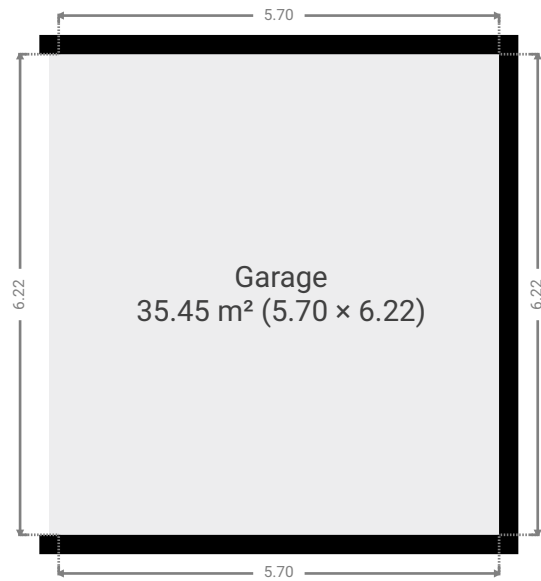

▼ Garage
Ground Floor

WIDTH: 12.50 m • LENGTH: 7.00 m
AREA: 87.50 m² • PERIMETER: 39.00 m

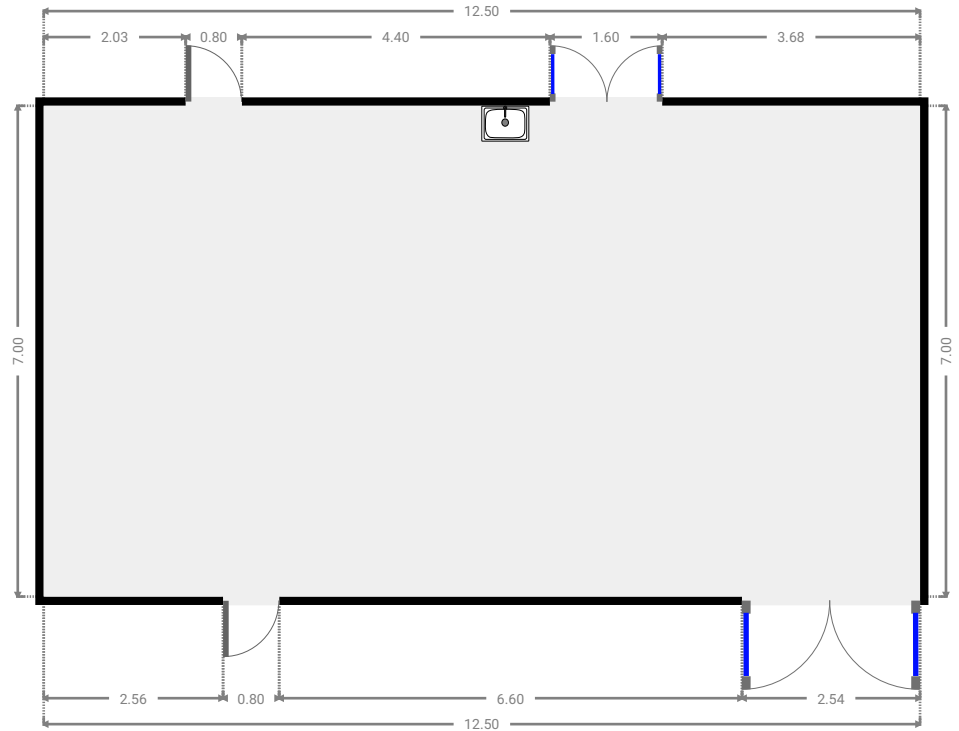
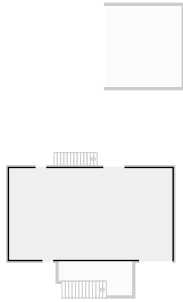

▼ Garage
Ground Floor

WIDTH: 5.70 m • LENGTH: 6.22 m
AREA: 35.45 m² • PERIMETER: 23.84 m

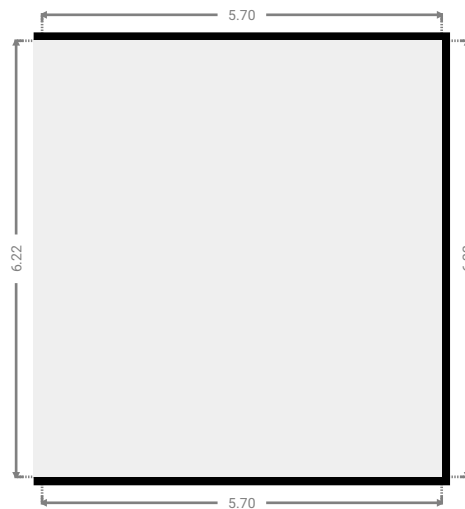
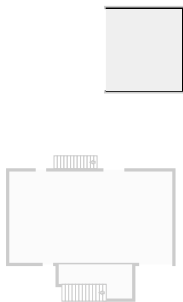

▼ Other
Ground Floor

WIDTH: 5.63 m • LENGTH: 2.62 m
AREA: 10.65 m² • PERIMETER: 16.50 m

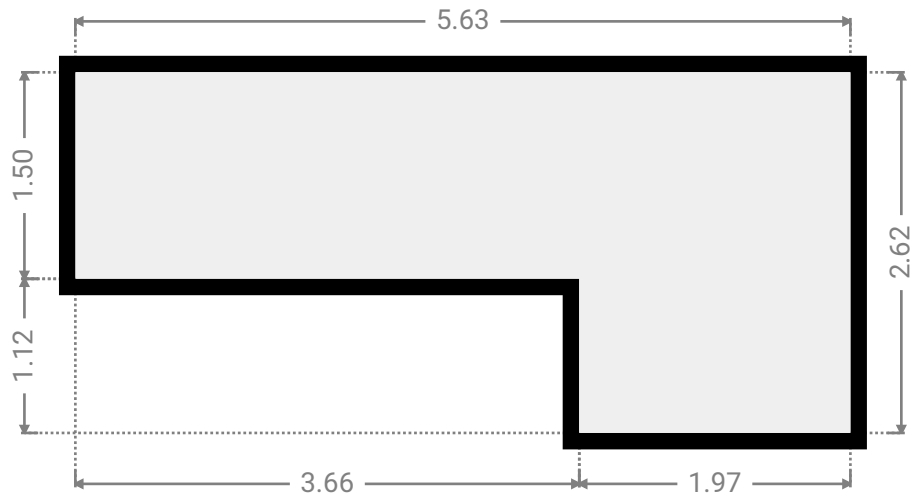
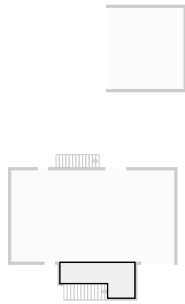

▼ 1st Floor

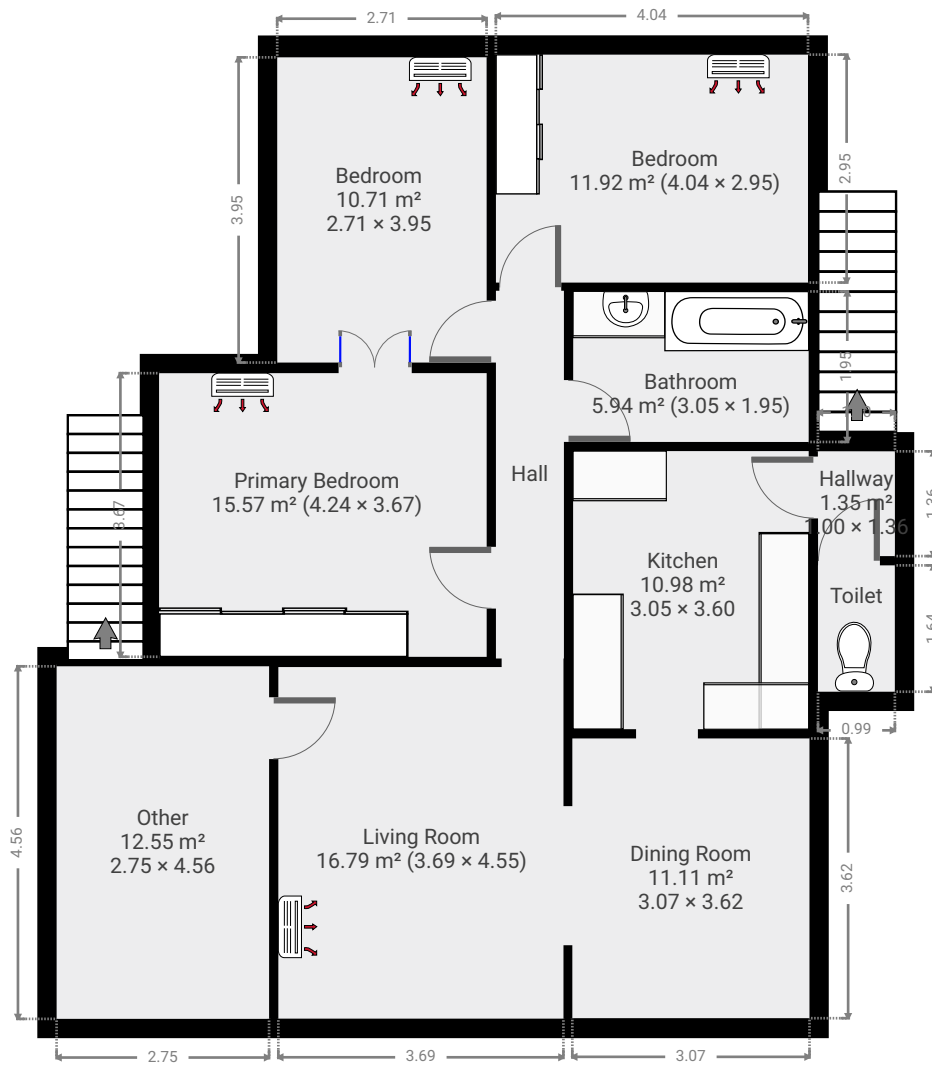

▼ **Bathroom**
1st Floor

WIDTH: 1.95 m • LENGTH: 3.05 m
AREA: 5.94 m² • PERIMETER: 9.99 m

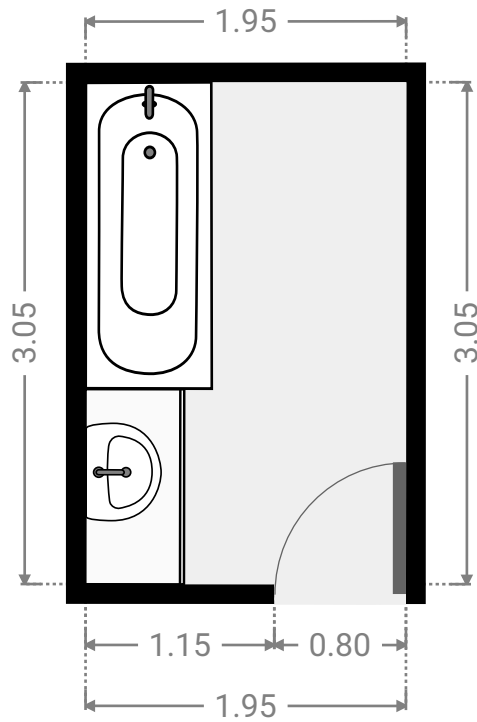
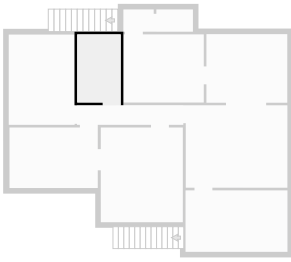

▼ **Bedroom**
1st Floor

WIDTH: 3.95 m • LENGTH: 2.71 m
AREA: 10.71 m² • PERIMETER: 13.32 m

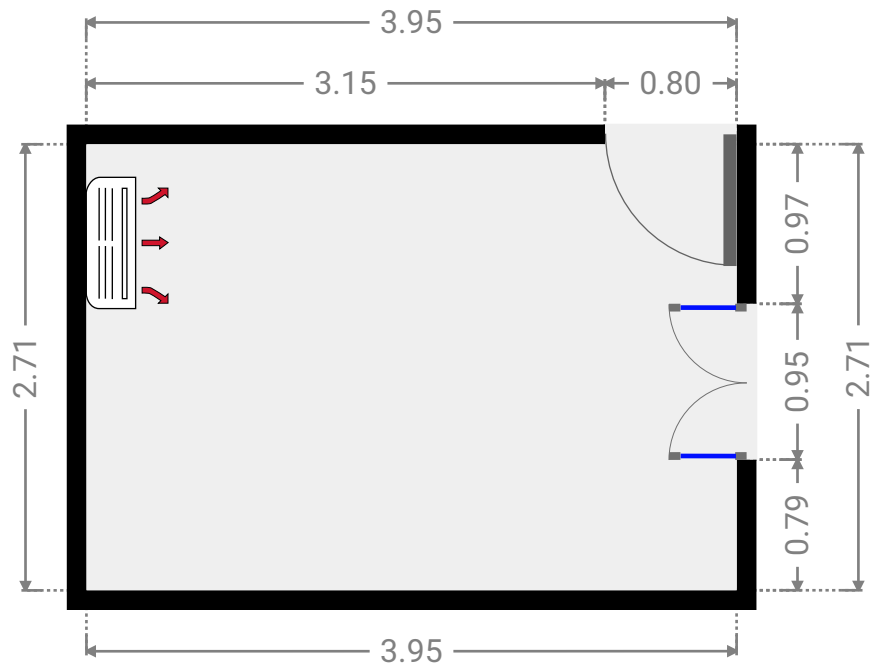
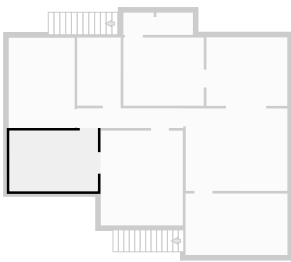

▼ Bedroom
1st Floor

WIDTH: 2.95 m • LENGTH: 4.04 m
AREA: 11.92 m² • PERIMETER: 13.98 m

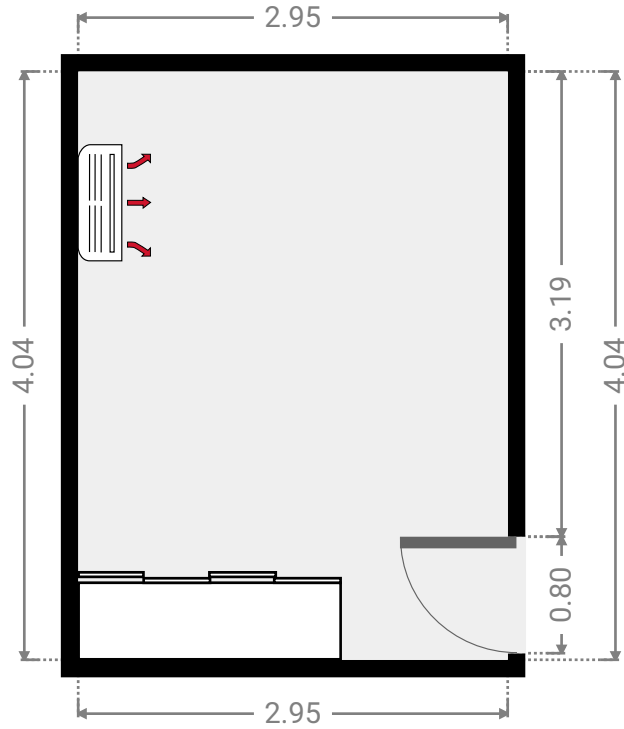
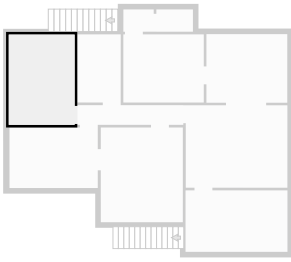

▼ Dining Room
1st Floor

WIDTH: 3.62 m • LENGTH: 3.07 m
AREA: 11.11 m² • PERIMETER: 13.38 m

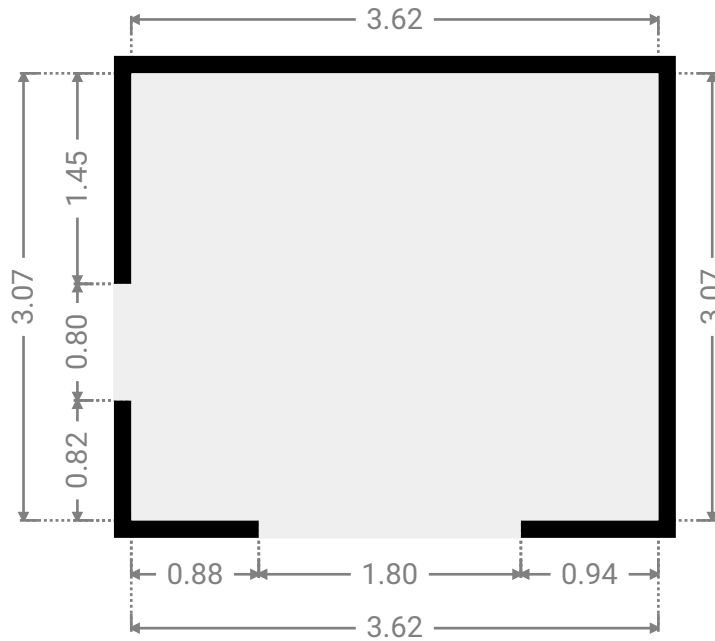
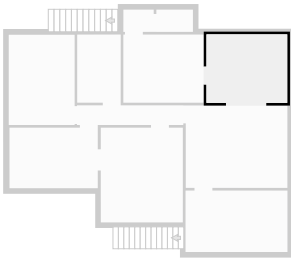

▼ **Hall**
1st Floor

WIDTH: 4.76 m • LENGTH: 0.88 m
AREA: 4.19 m² • PERIMETER: 11.28 m

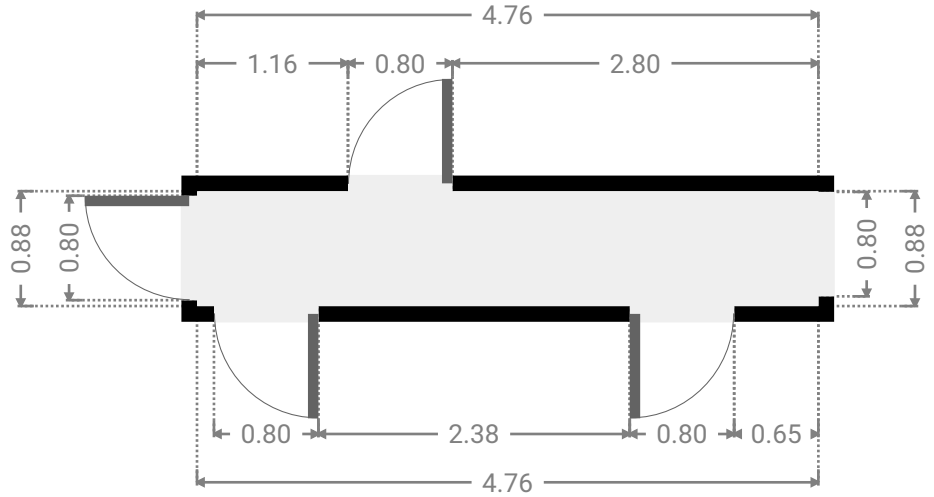
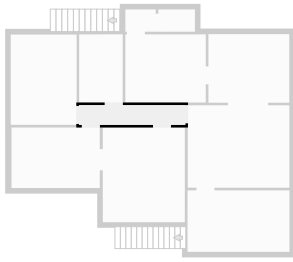

▼ **Hallway**
1st Floor

WIDTH: 1.36 m • LENGTH: 1.00 m
AREA: 1.35 m² • PERIMETER: 4.70 m

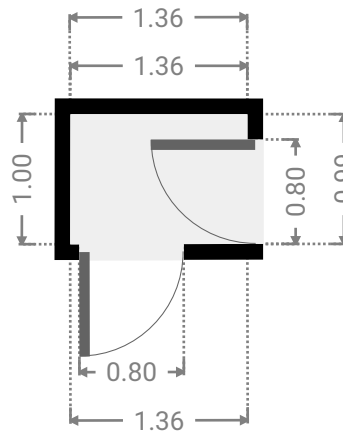
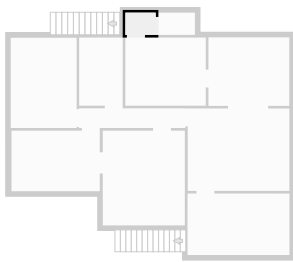

▼ **Kitchen**
1st Floor

WIDTH: 3.60 m • LENGTH: 3.05 m
AREA: 10.98 m² • PERIMETER: 13.30 m

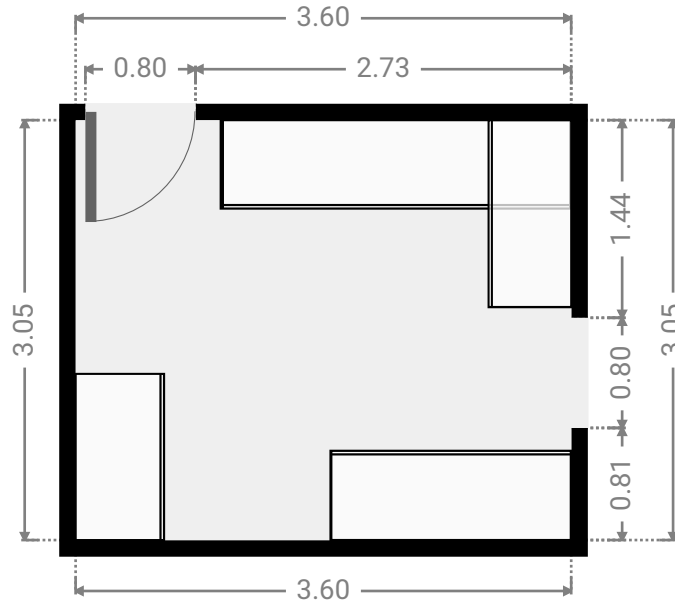
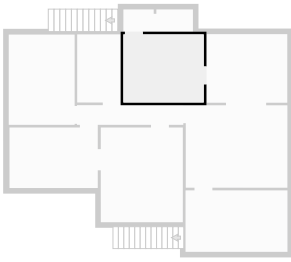

▼ **Living Room**
1st Floor

WIDTH: 4.55 m • LENGTH: 3.69 m
AREA: 16.79 m² • PERIMETER: 16.48 m

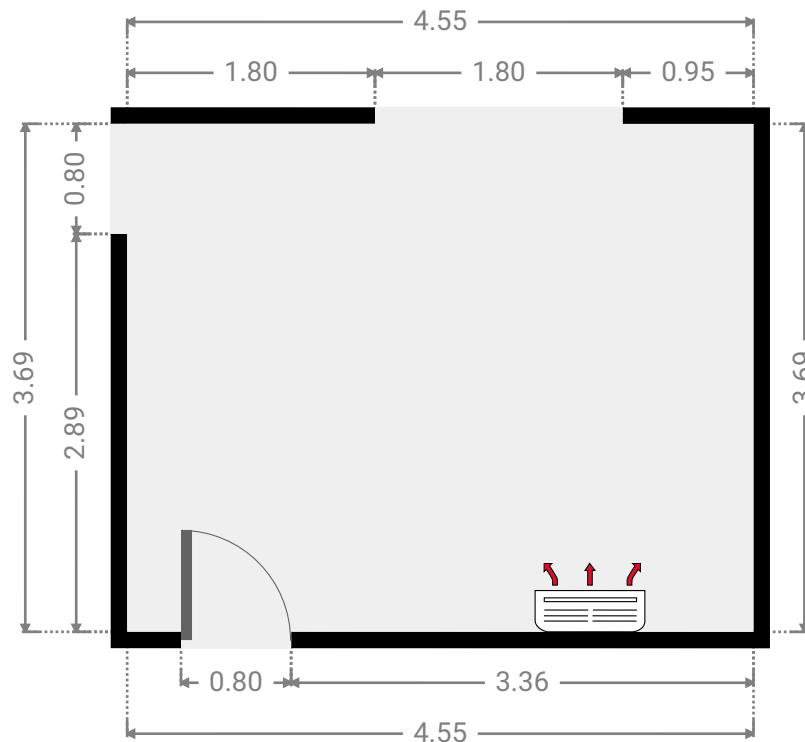
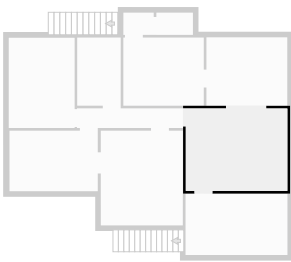

▼ Other
1st Floor

WIDTH: 4.56 m • LENGTH: 2.75 m
AREA: 12.55 m² • PERIMETER: 14.63 m

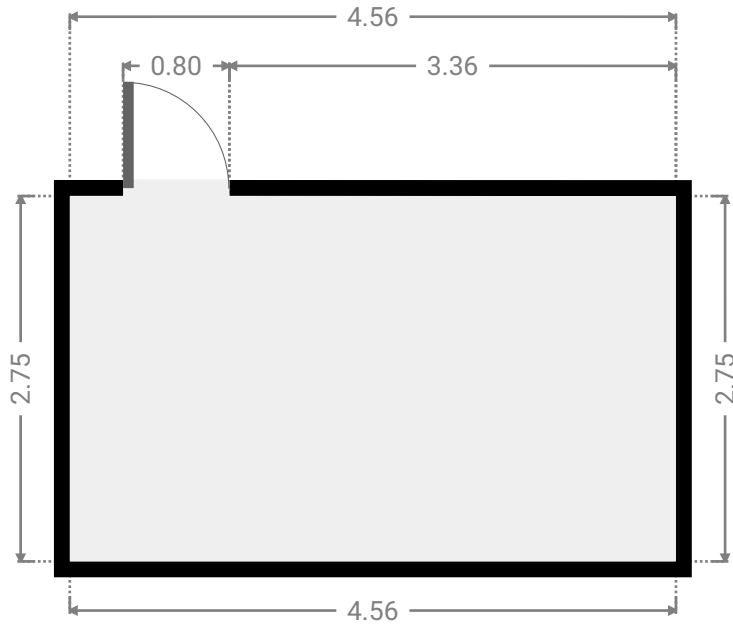
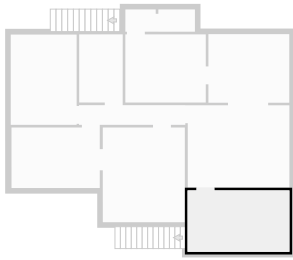

▼ Primary Bedroom
1st Floor

WIDTH: 3.67 m • LENGTH: 4.24 m
AREA: 15.57 m² • PERIMETER: 15.82 m

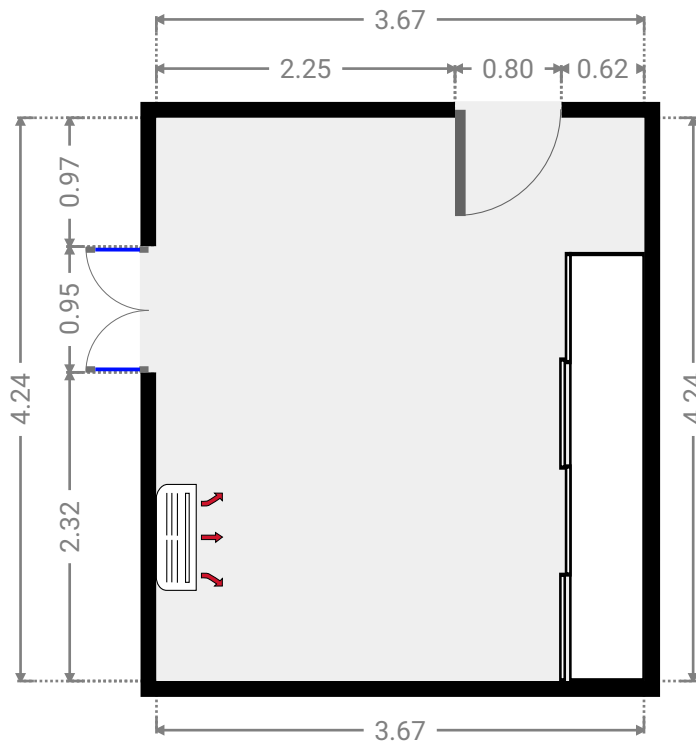
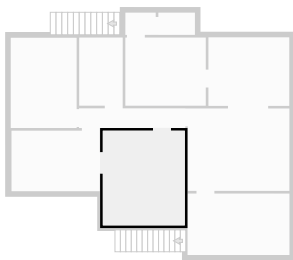

▼ Toilet
1st Floor

WIDTH: 1.64 m • LENGTH: 1.00 m
AREA: 1.63 m² • PERIMETER: 5.26 m

