

6/104 Kent Street

SUBMITTED BY
Ray White Rockhampton Casey
stockers@cqoz.com

CREATED ON
2022-08-09

Floors 1

▼ Ground Floor

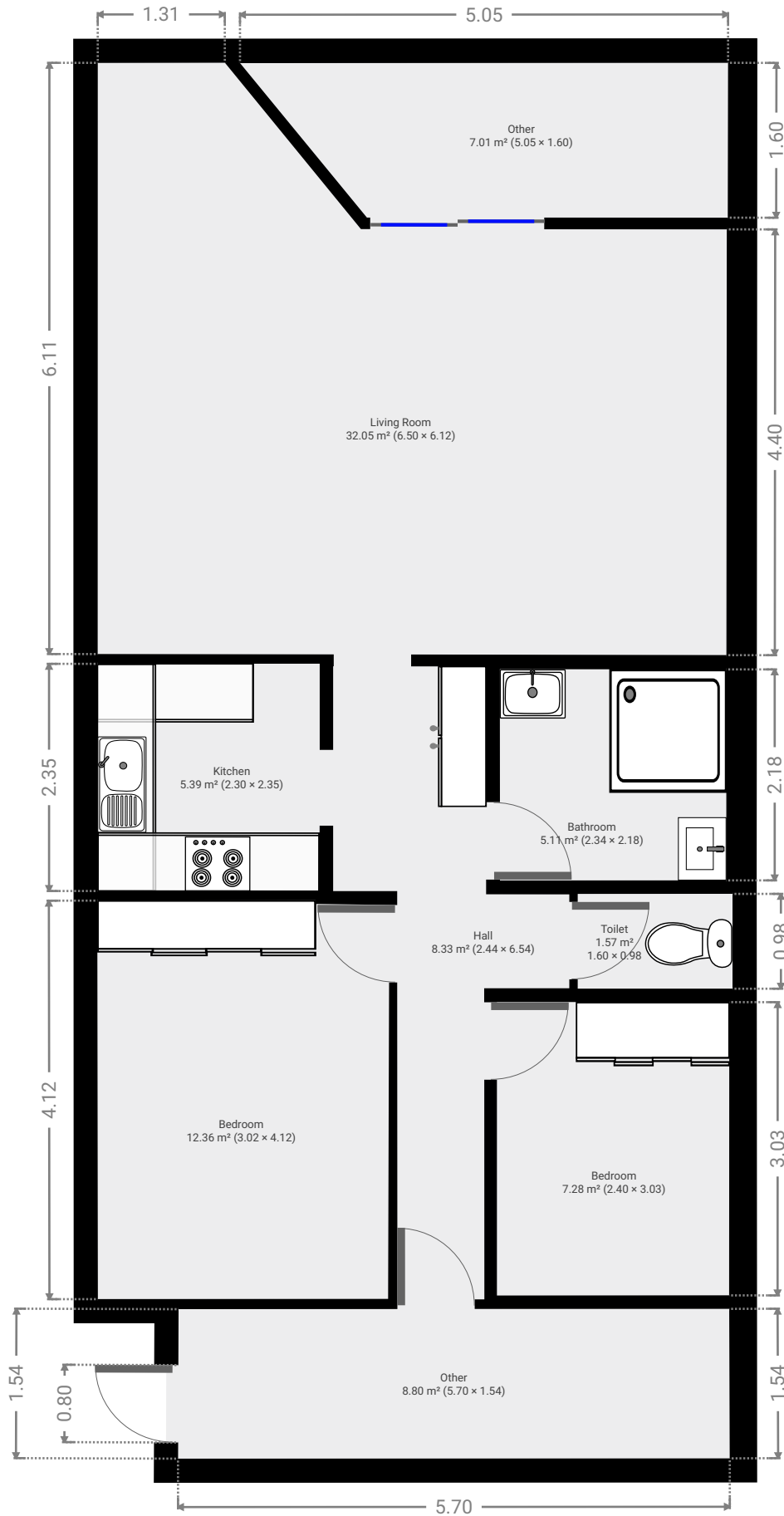

▼ Bathroom
Ground Floor

WIDTH: 2.34 m • LENGTH: 2.18 m
AREA: 5.11 m² • PERIMETER: 9.04 m

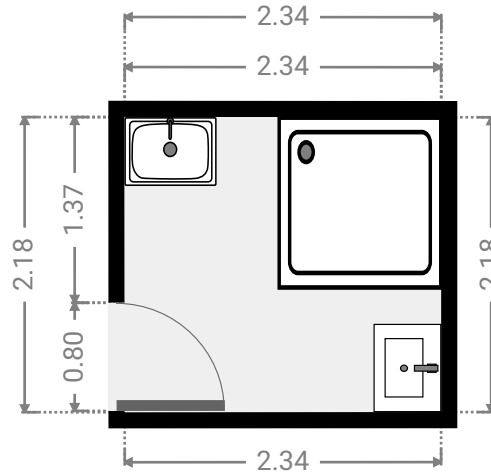
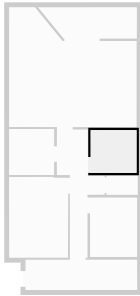

▼ Bedroom
Ground Floor

WIDTH: 3.02 m • LENGTH: 4.12 m
AREA: 12.36 m² • PERIMETER: 14.25 m

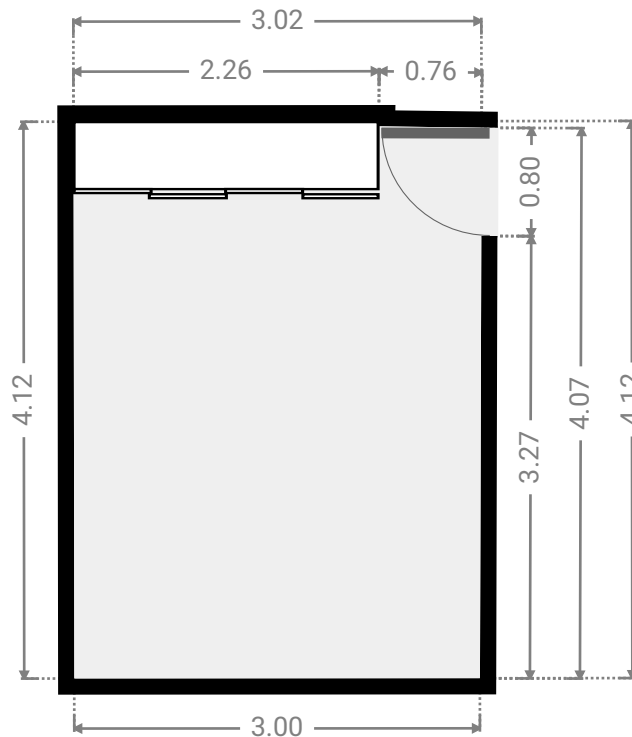
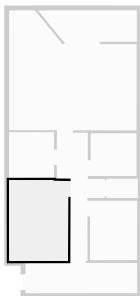

▼ **Bedroom**
Ground Floor

WIDTH: 2.40 m • LENGTH: 3.03 m
AREA: 7.28 m² • PERIMETER: 10.87 m

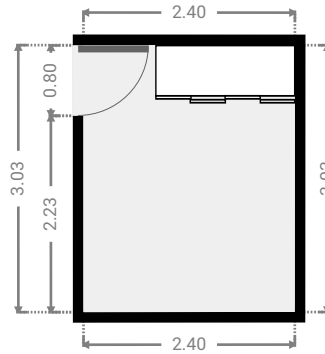
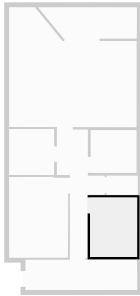

▼ **Hall**
Ground Floor

WIDTH: 2.44 m • LENGTH: 6.54 m
AREA: 8.33 m² • PERIMETER: 17.97 m

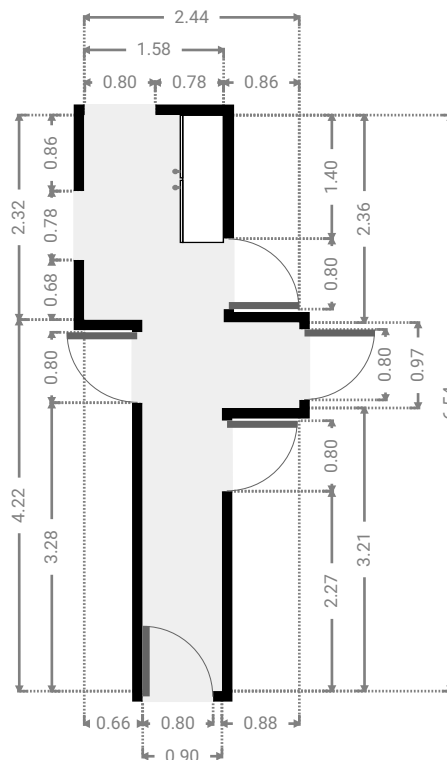
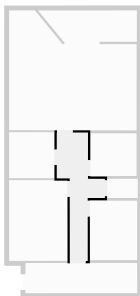

FLOORS: 1

▼ **Kitchen**
Ground Floor

WIDTH: 2.30 m • LENGTH: 2.35 m
AREA: 5.39 m² • PERIMETER: 9.29 m

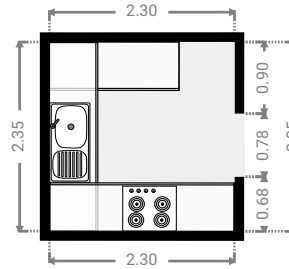
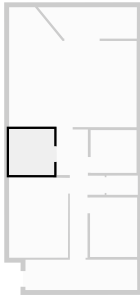

▼ **Living Room**
Ground Floor

WIDTH: 6.50 m • LENGTH: 6.12 m
AREA: 32.05 m² • PERIMETER: 24.33 m

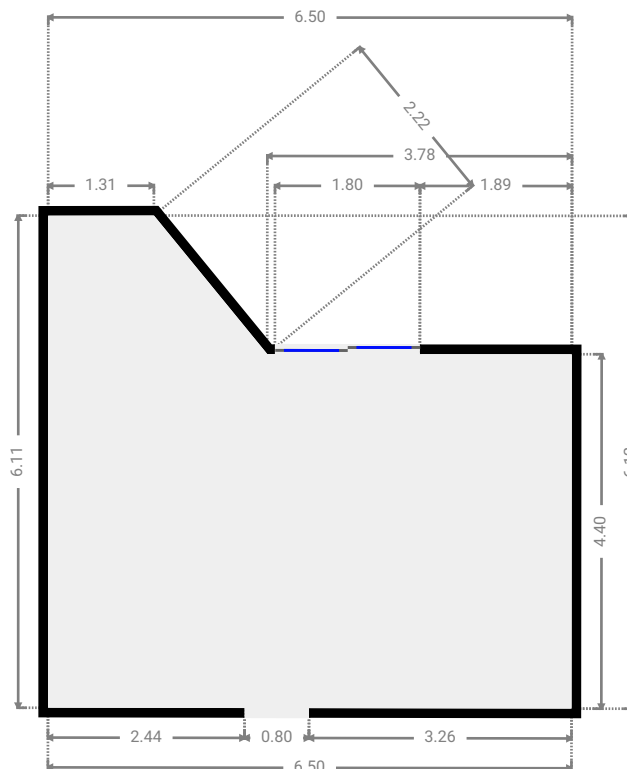
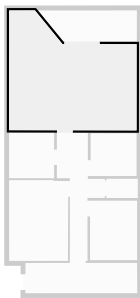

▼ Other
Ground Floor

WIDTH: 5.05 m • LENGTH: 1.60 m
AREA: 7.01 m² • PERIMETER: 12.44 m

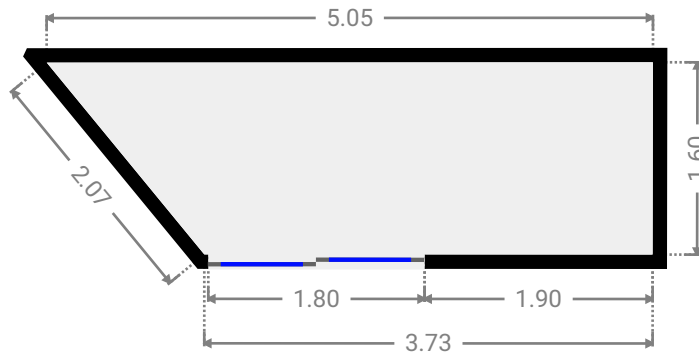
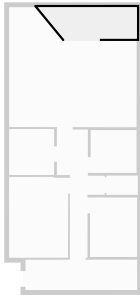

▼ Other
Ground Floor

WIDTH: 5.70 m • LENGTH: 1.54 m
AREA: 8.80 m² • PERIMETER: 14.49 m

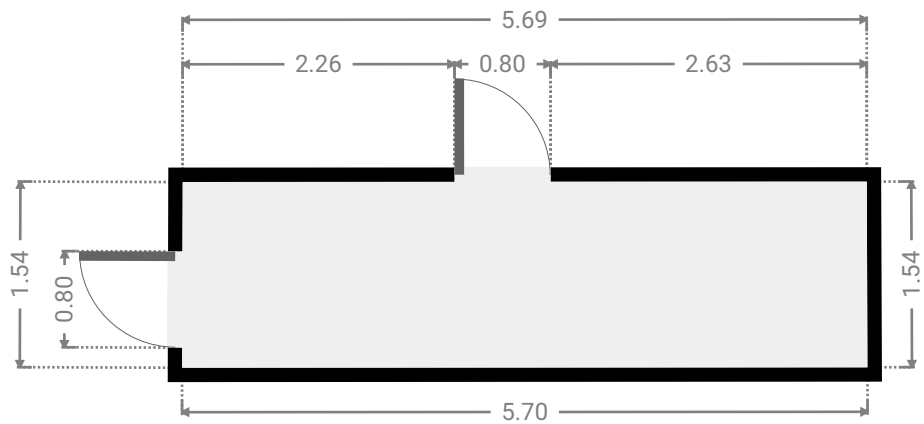
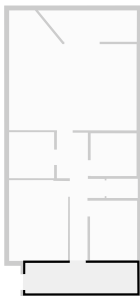

▼ Toilet
Ground Floor

WIDTH: 1.60 m • LENGTH: 0.98 m
AREA: 1.57 m² • PERIMETER: 5.16 m

