

58 Wandal Road

SUBMITTED BY

Ray White Rockhampton Casey
stockers@cqoz.com

CREATED ON

2022-06-27

Floors

2

▼ Ground Floor

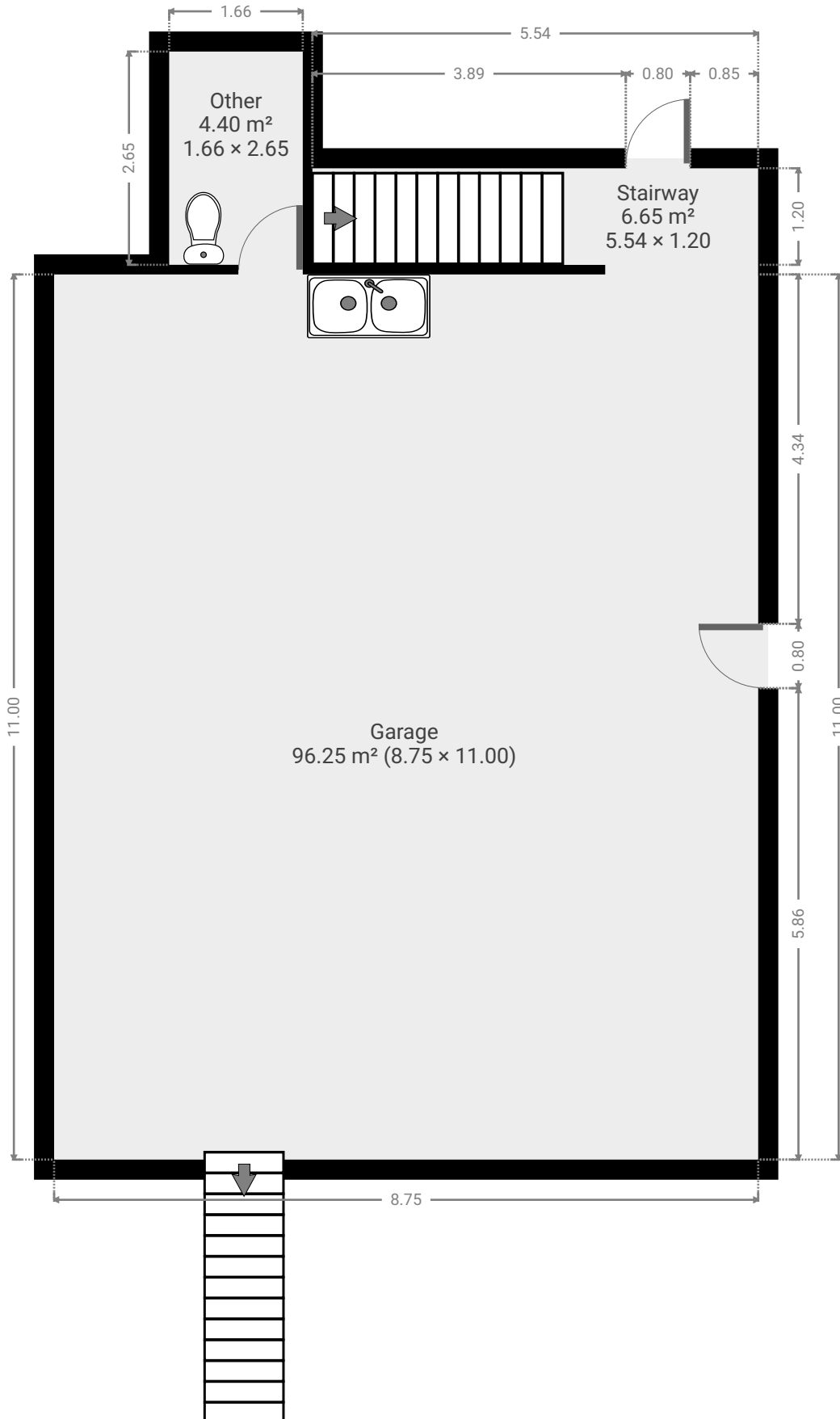

FLOORS: 2

▼ **Garage**
Ground Floor

WIDTH: 8.75 m • LENGTH: 11.00 m
AREA: 96.25 m² • PERIMETER: 39.50 m

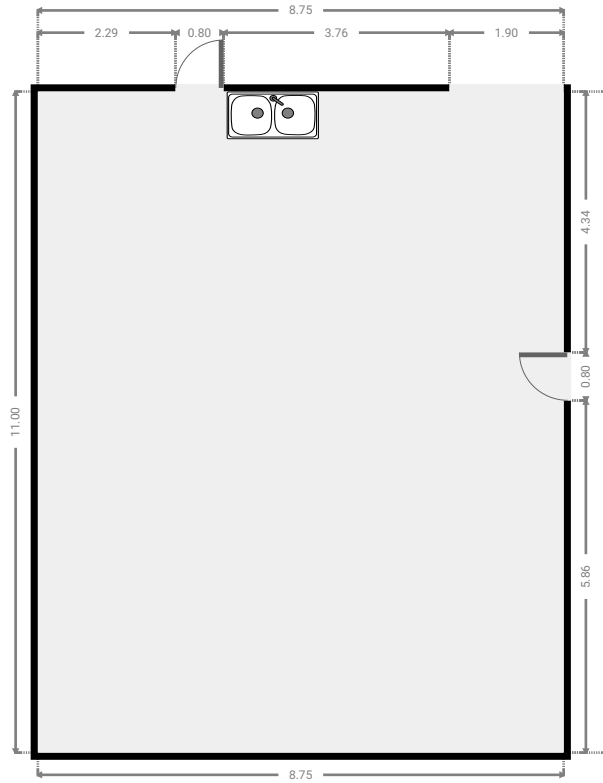
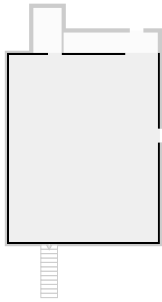

▼ **Other**
Ground Floor

WIDTH: 1.66 m • LENGTH: 2.65 m
AREA: 4.40 m² • PERIMETER: 8.62 m

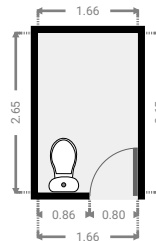
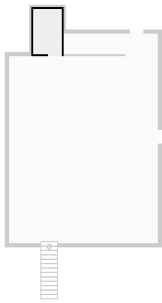

▼ **Stairway**
Ground Floor

WIDTH: 5.54 m • LENGTH: 1.20 m
AREA: 6.65 m² • PERIMETER: 13.48 m

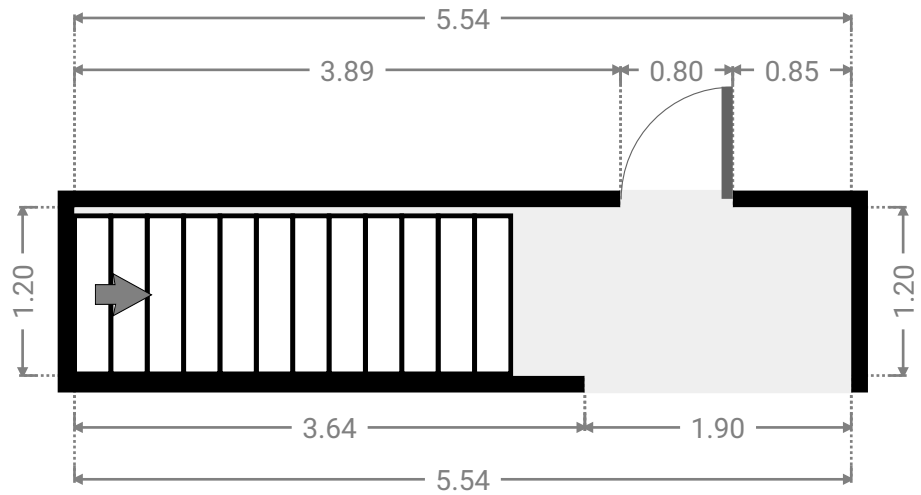

▼ 1st Floor

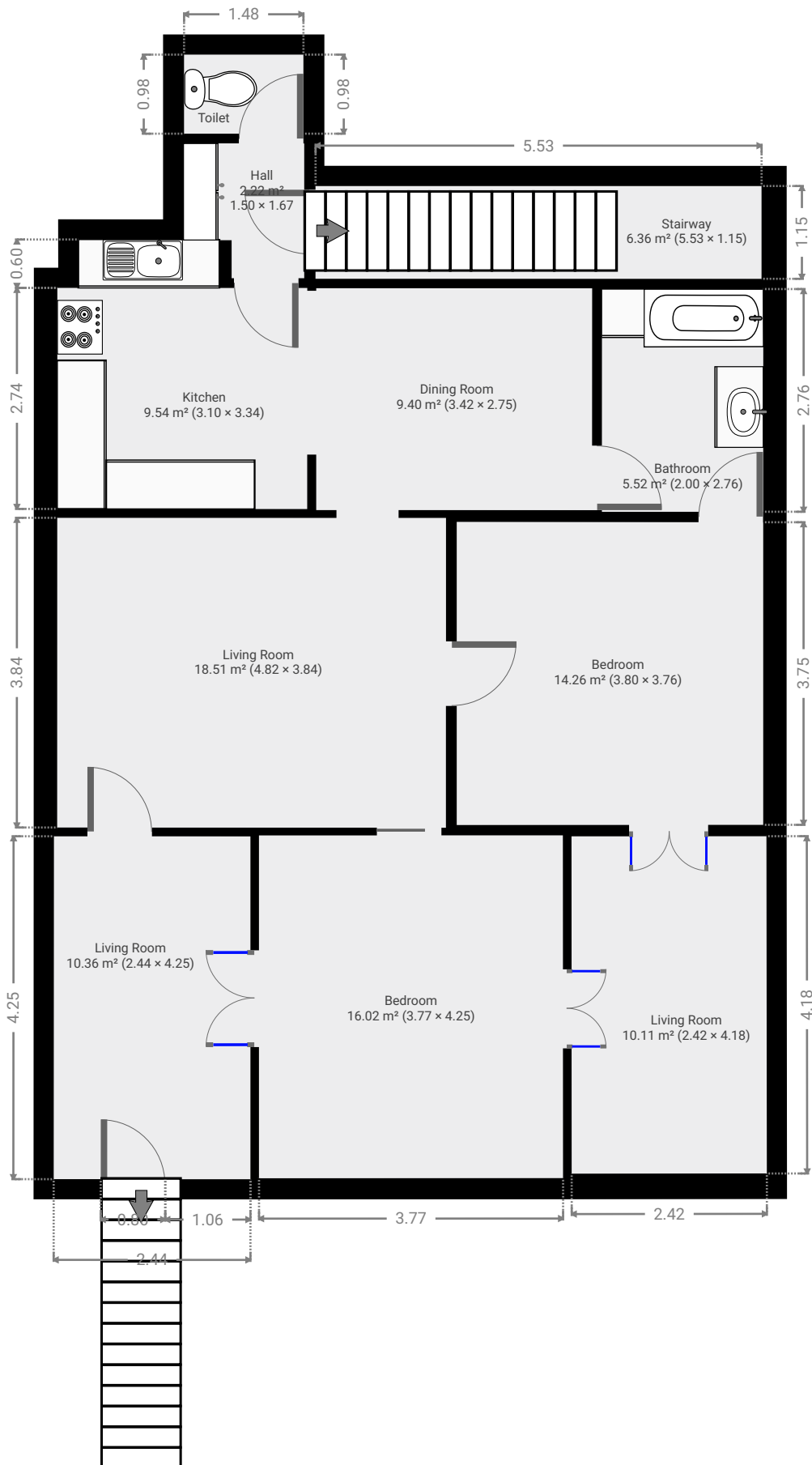

▼ Bathroom
1st Floor

WIDTH: 2.00 m • LENGTH: 2.76 m
AREA: 5.52 m² • PERIMETER: 9.52 m

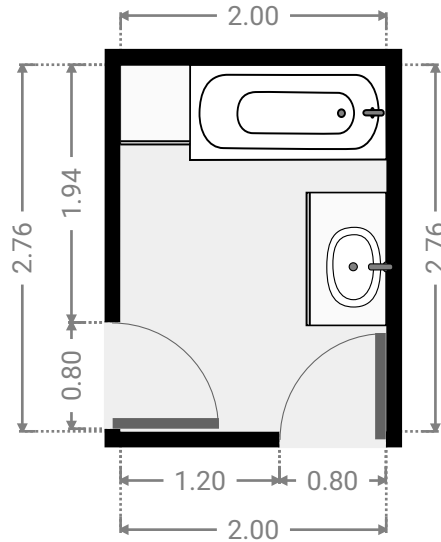
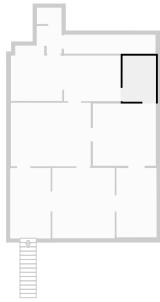

▼ Bedroom
1st Floor

WIDTH: 3.77 m • LENGTH: 4.25 m
AREA: 16.02 m² • PERIMETER: 16.04 m

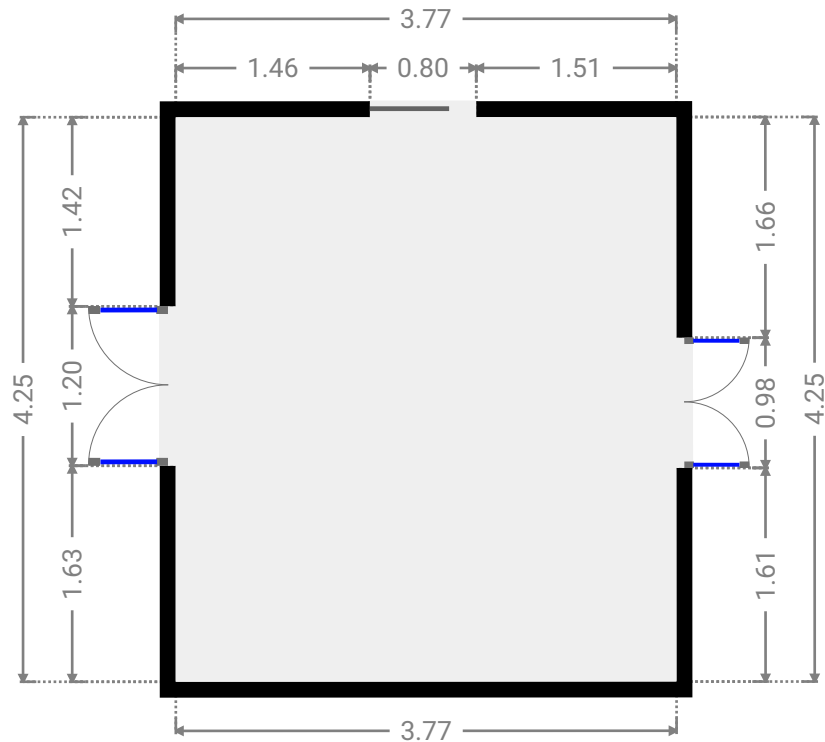
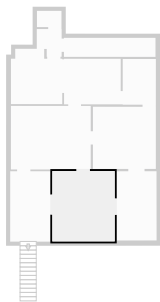

▼ **Bedroom**
1st Floor

WIDTH: 3.80 m • LENGTH: 3.76 m
AREA: 14.26 m² • PERIMETER: 15.11 m

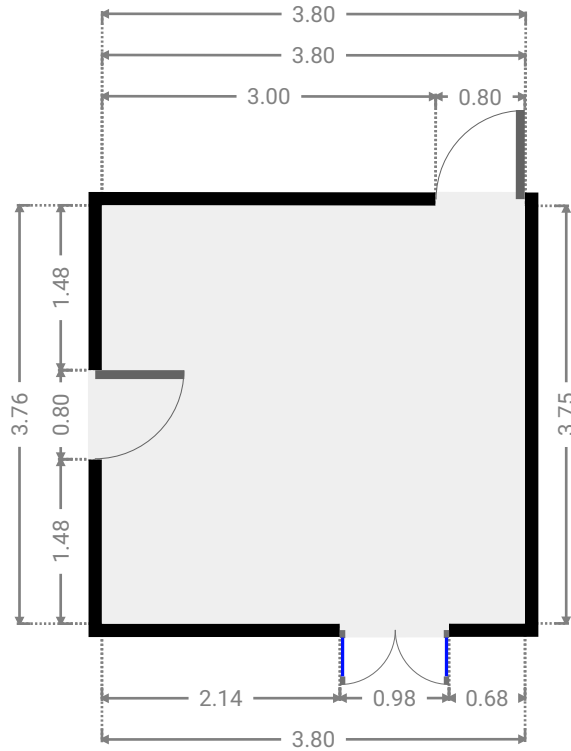
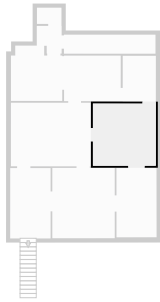

▼ **Dining Room**
1st Floor

WIDTH: 3.42 m • LENGTH: 2.75 m
AREA: 9.40 m² • PERIMETER: 12.34 m

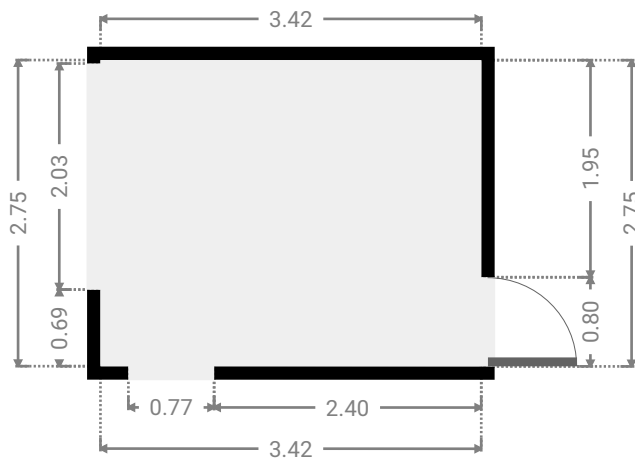
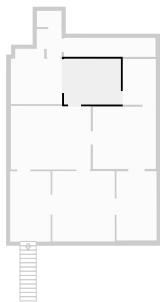

▼ **Hall**
1st Floor

WIDTH: 1.50 m • LENGTH: 1.67 m
AREA: 2.22 m² • PERIMETER: 6.34 m

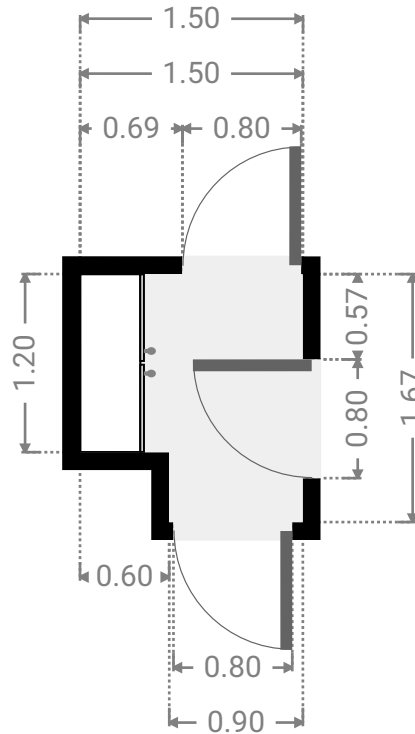
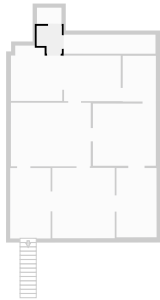

▼ **Kitchen**
1st Floor

WIDTH: 3.10 m • LENGTH: 3.34 m
AREA: 9.54 m² • PERIMETER: 12.88 m

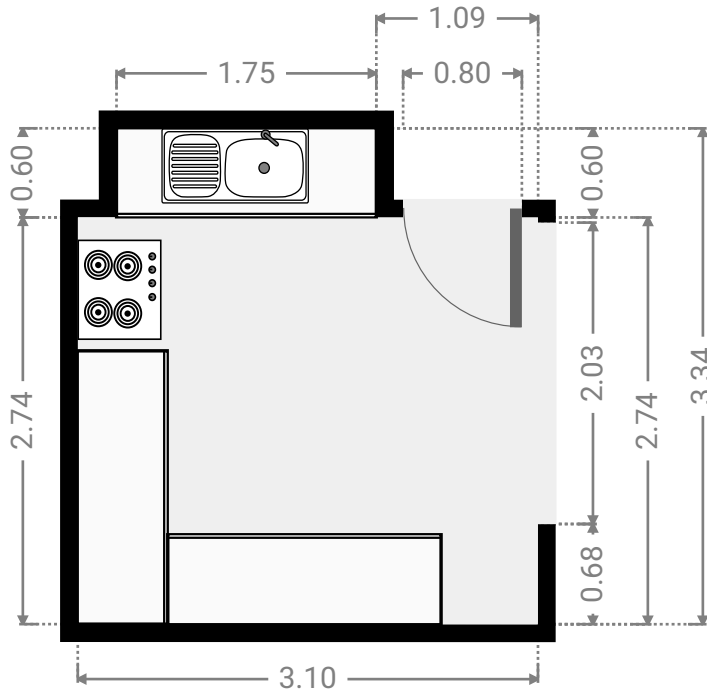
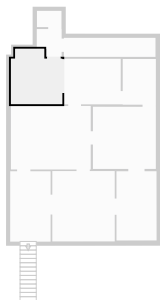

▼ Living Room
1st Floor

WIDTH: 2.44 m • LENGTH: 4.25 m
AREA: 10.36 m² • PERIMETER: 13.38 m

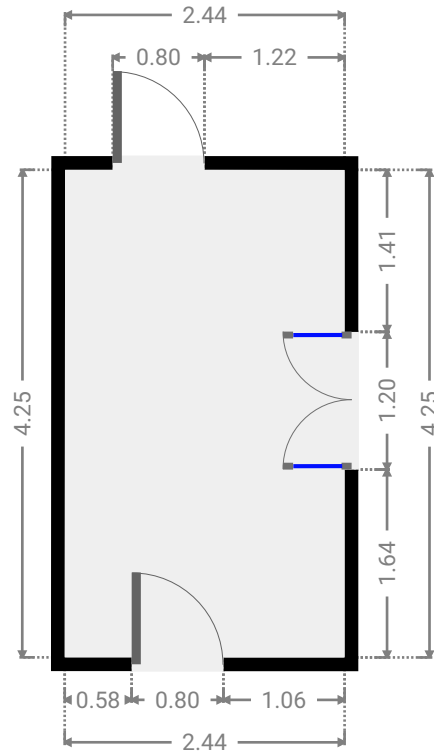
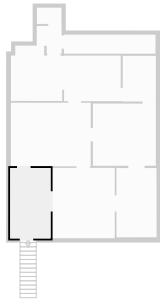

▼ Living Room
1st Floor

WIDTH: 4.82 m • LENGTH: 3.84 m
AREA: 18.51 m² • PERIMETER: 17.32 m

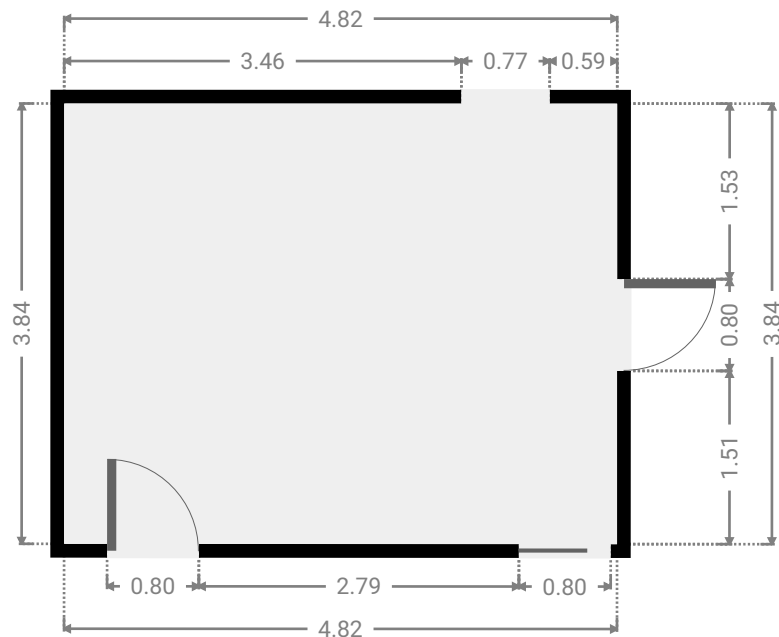
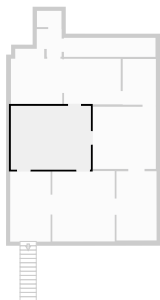

▼ **Living Room**
1st Floor

WIDTH: 2.42 m • LENGTH: 4.18 m
AREA: 10.11 m² • PERIMETER: 13.20 m

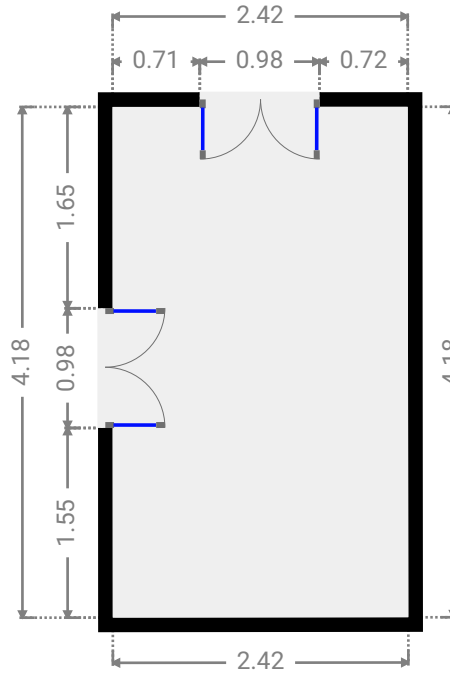
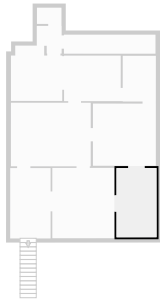

▼ **Stairway**
1st Floor

WIDTH: 5.53 m • LENGTH: 1.15 m
AREA: 6.36 m² • PERIMETER: 13.36 m

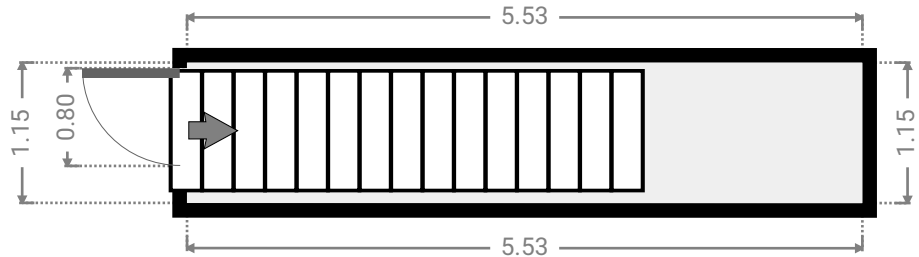
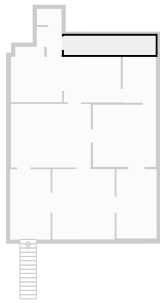

▼ Toilet
1st Floor

WIDTH: 1.48 m • LENGTH: 0.98 m
AREA: 1.45 m² • PERIMETER: 4.92 m

