

53 Corella Drive

SUBMITTED BY
Ray White Rockhampton Casey
stockers@cqoz.com

CREATED ON
2022-12-19

Floors
1

▼ Ground Floor



FLOORS: 1

▼ **Bathroom**
Ground Floor

WIDTH: 1.82 m • LENGTH: 2.56 m
AREA: 4.66 m² • PERIMETER: 8.76 m

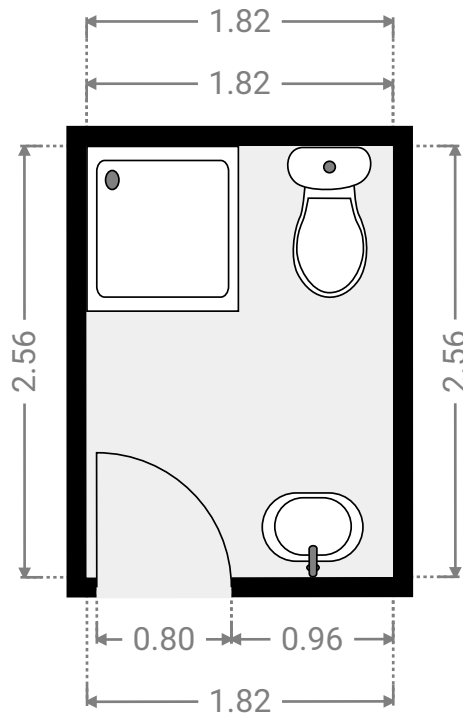
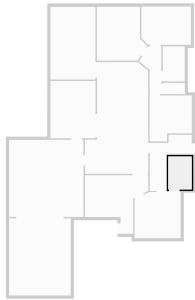

▼ **Bathroom**
Ground Floor

WIDTH: 1.70 m • LENGTH: 2.73 m
AREA: 4.64 m² • PERIMETER: 8.86 m

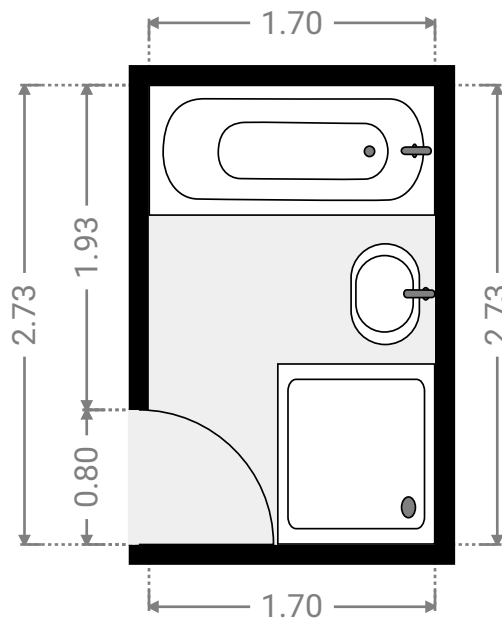
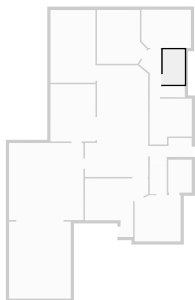

FLOORS: 1

▼ **Bedroom**
Ground Floor

WIDTH: 3.28 m • LENGTH: 3.57 m
AREA: 10.51 m² • PERIMETER: 13.69 m

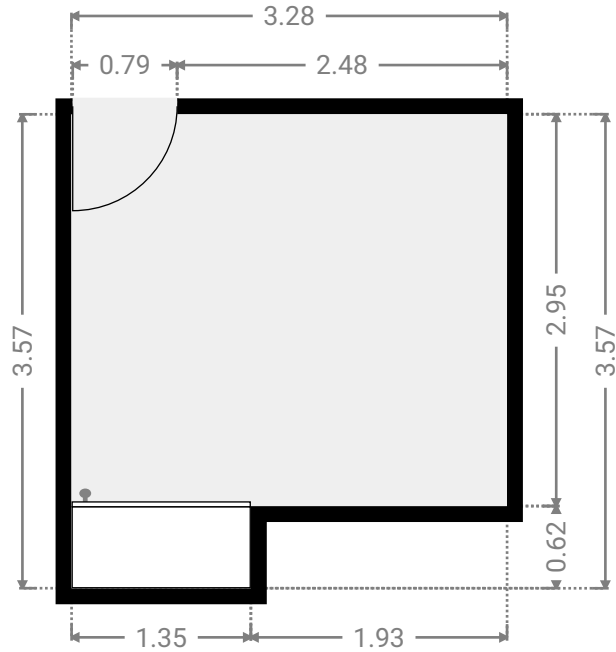
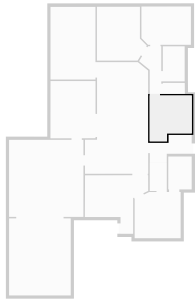

▼ **Bedroom**
Ground Floor

WIDTH: 3.88 m • LENGTH: 4.19 m
AREA: 14.39 m² • PERIMETER: 15.32 m

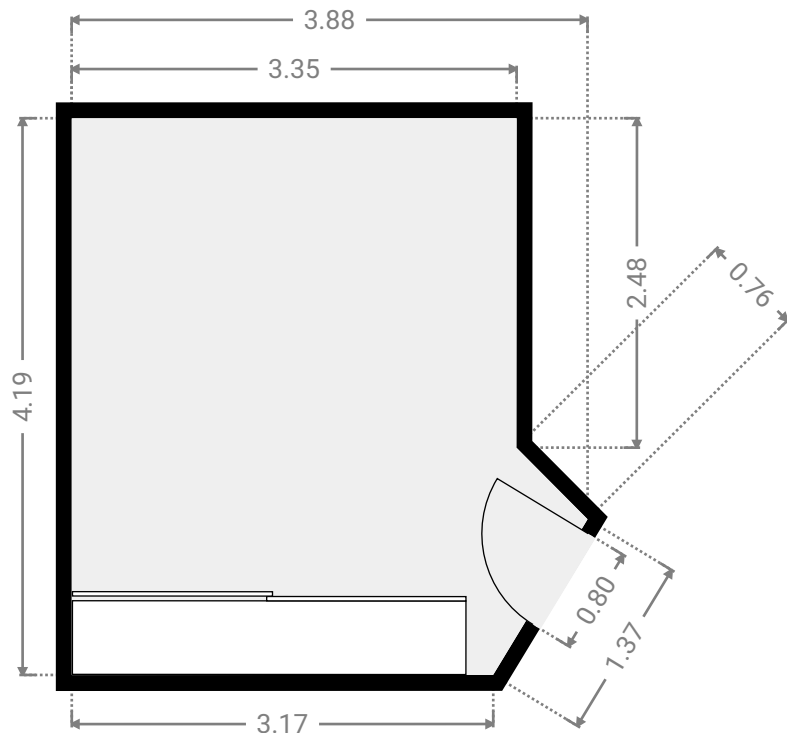
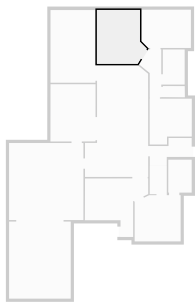

FLOORS: 1

▼ **Bedroom**
Ground Floor

WIDTH: 3.85 m • LENGTH: 2.98 m
AREA: 11.34 m² • PERIMETER: 13.36 m

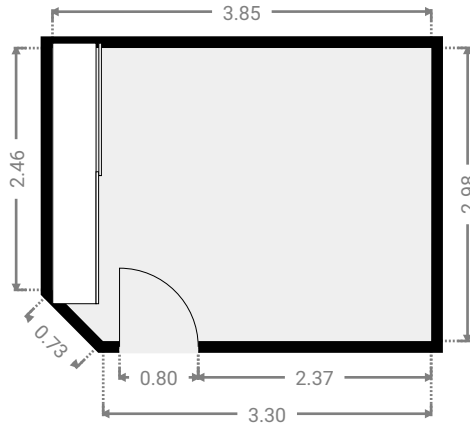
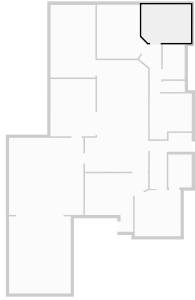

▼ **Garage**
Ground Floor

WIDTH: 5.79 m • LENGTH: 6.00 m
AREA: 34.74 m² • PERIMETER: 23.58 m

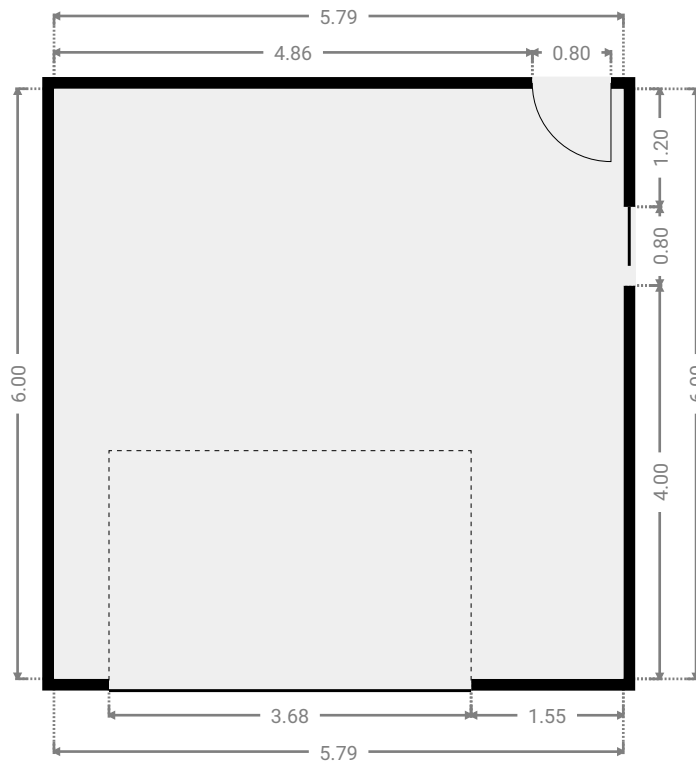
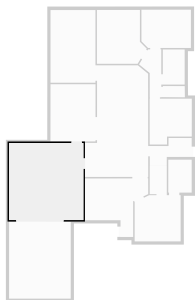

FLOORS: 1

▼ **Garage**
Ground Floor

WIDTH: 4.80 m • LENGTH: 6.00 m
AREA: 28.80 m² • PERIMETER: 21.60 m

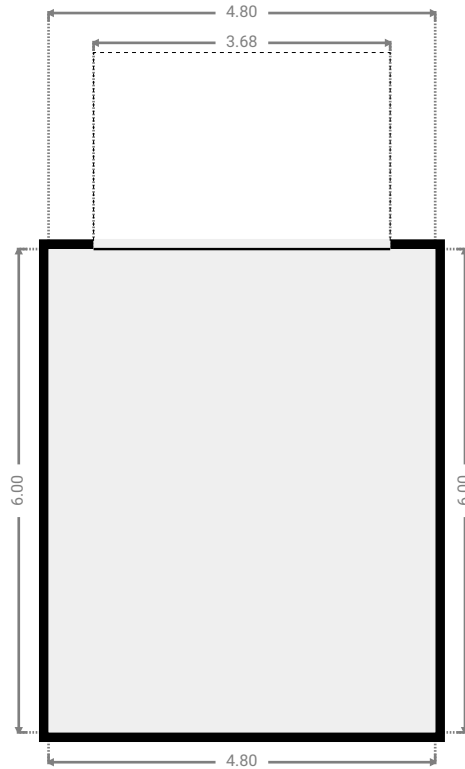
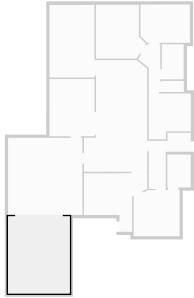

▼ **Hall**
Ground Floor

WIDTH: 1.73 m • LENGTH: 3.73 m
AREA: 4.19 m² • PERIMETER: 9.98 m

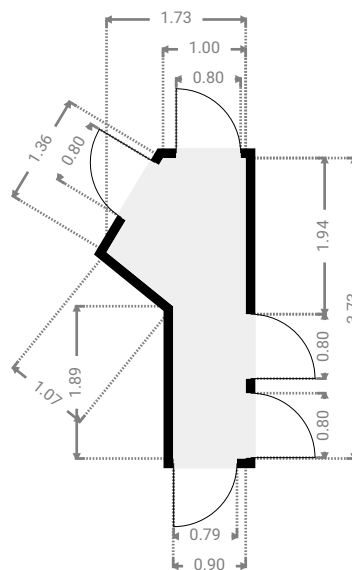
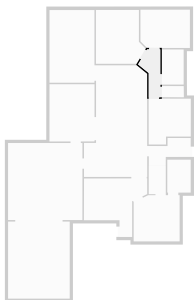

▼ **Kitchen**
Ground Floor

WIDTH: 4.93 m • LENGTH: 8.69 m
AREA: 36.84 m² • PERIMETER: 26.81 m

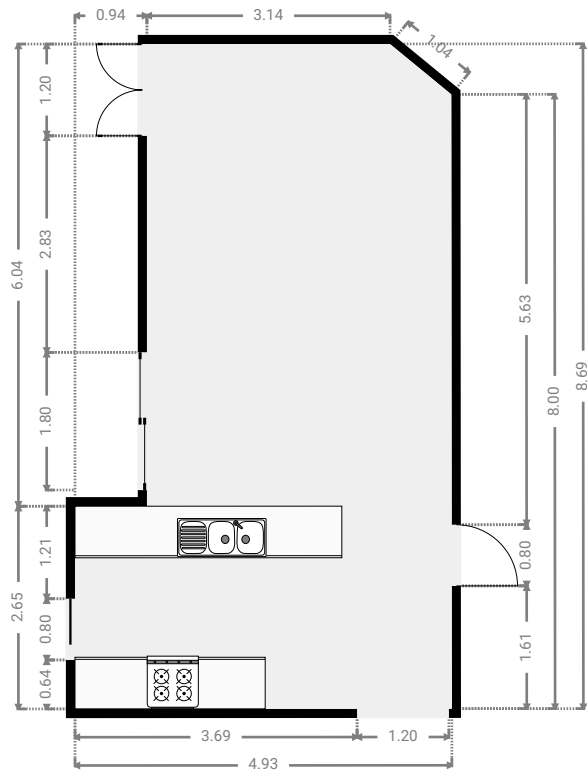
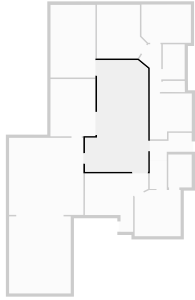

▼ **Laundry Room**
Ground Floor

WIDTH: 3.26 m • LENGTH: 2.17 m
AREA: 4.82 m² • PERIMETER: 10.87 m

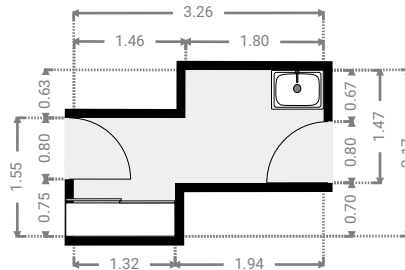
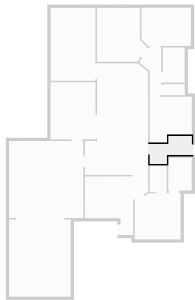

FLOORS: 1

▼ **Living Room**
Ground Floor

WIDTH: 4.94 m • LENGTH: 4.56 m
AREA: 15.26 m² • PERIMETER: 18.54 m

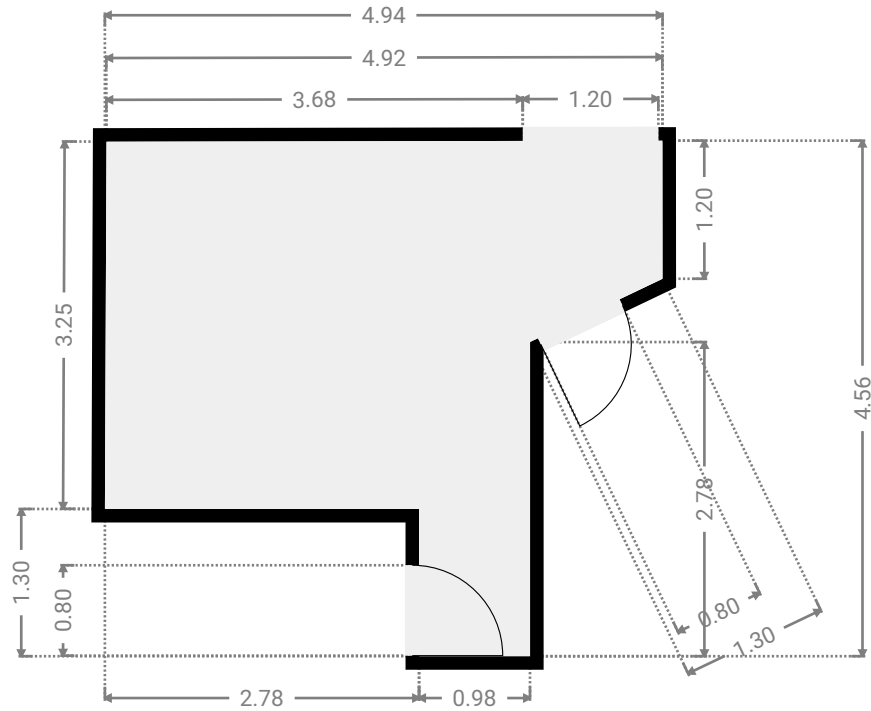
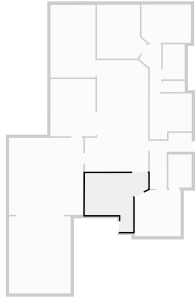

▼ **Living Room**
Ground Floor

WIDTH: 3.50 m • LENGTH: 5.66 m
AREA: 19.80 m² • PERIMETER: 18.31 m

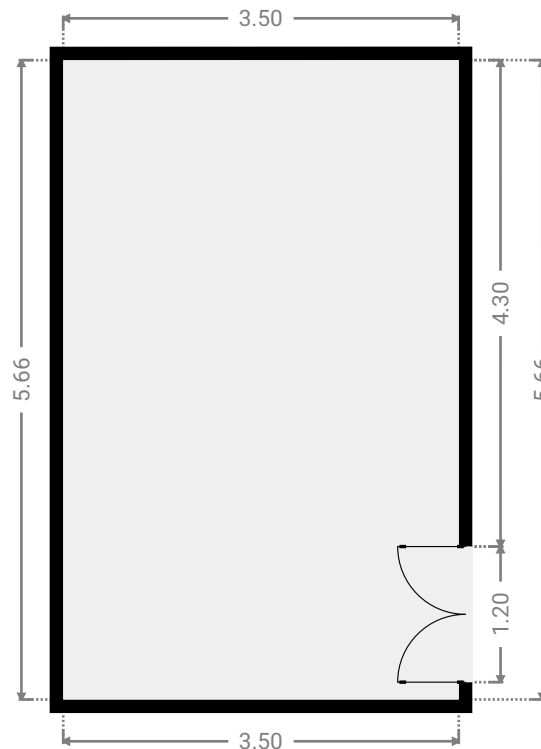
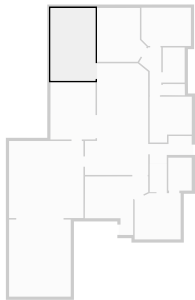

▼ **Other**
Ground Floor

WIDTH: 3.52 m • LENGTH: 4.46 m
AREA: 15.63 m² • PERIMETER: 15.93 m

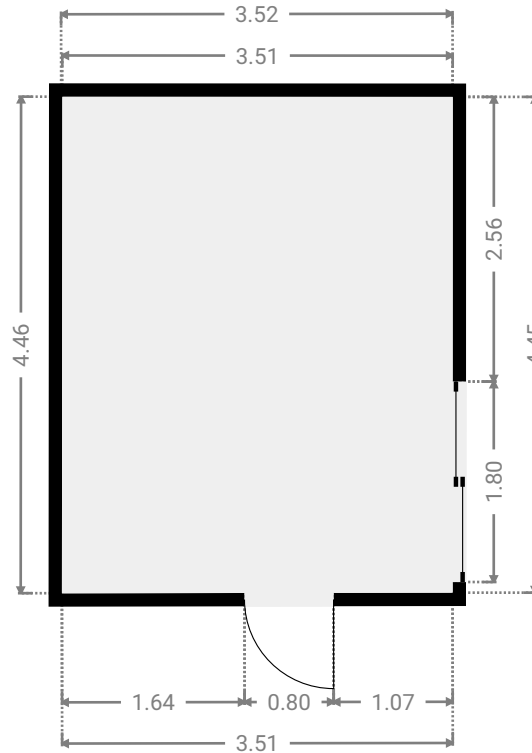
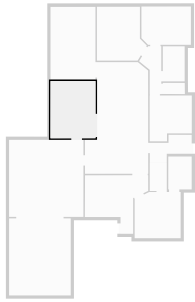

▼ **Primary Bedroom**
Ground Floor

WIDTH: 3.58 m • LENGTH: 3.60 m
AREA: 12.57 m² • PERIMETER: 13.93 m

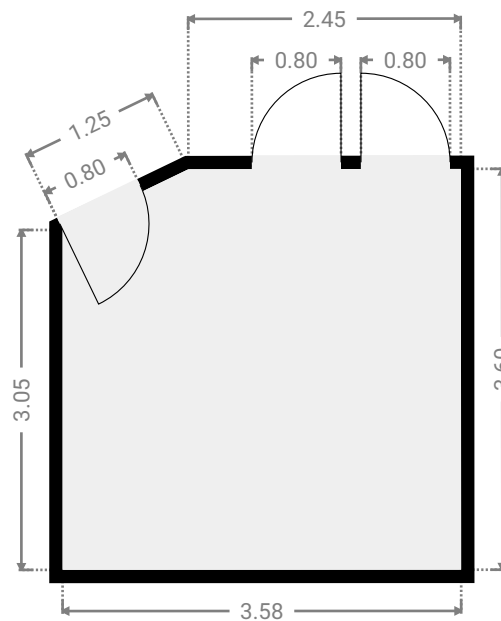
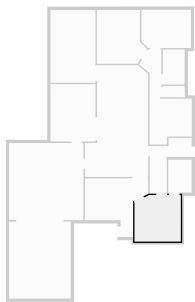

FLOORS: 1

▼ **Closet**
Ground Floor

WIDTH: 1.33 m • LENGTH: 2.20 m
AREA: 2.92 m² • PERIMETER: 7.05 m

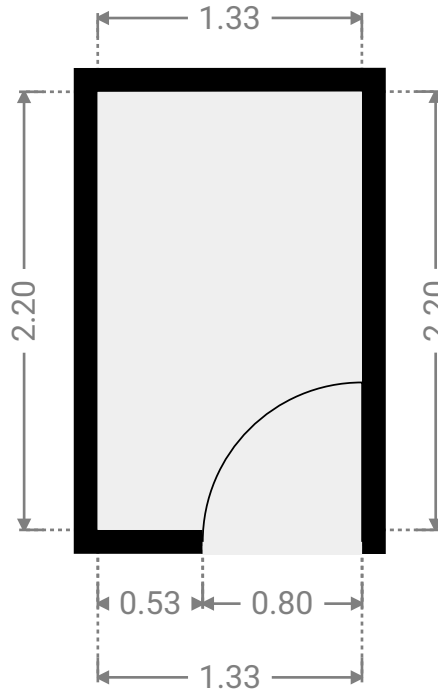
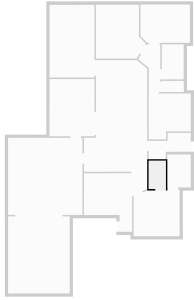

▼ **Toilet**
Ground Floor

WIDTH: 1.72 m • LENGTH: 0.87 m
AREA: 1.48 m² • PERIMETER: 5.16 m

