

52 Wiggington Street

SUBMITTED BY

Ray White Rockhampton Casey
stockers@cqoz.com

CREATED ON

2022-10-19

Floors

1

▼ Ground Floor

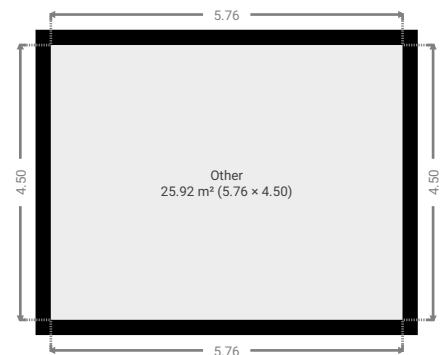
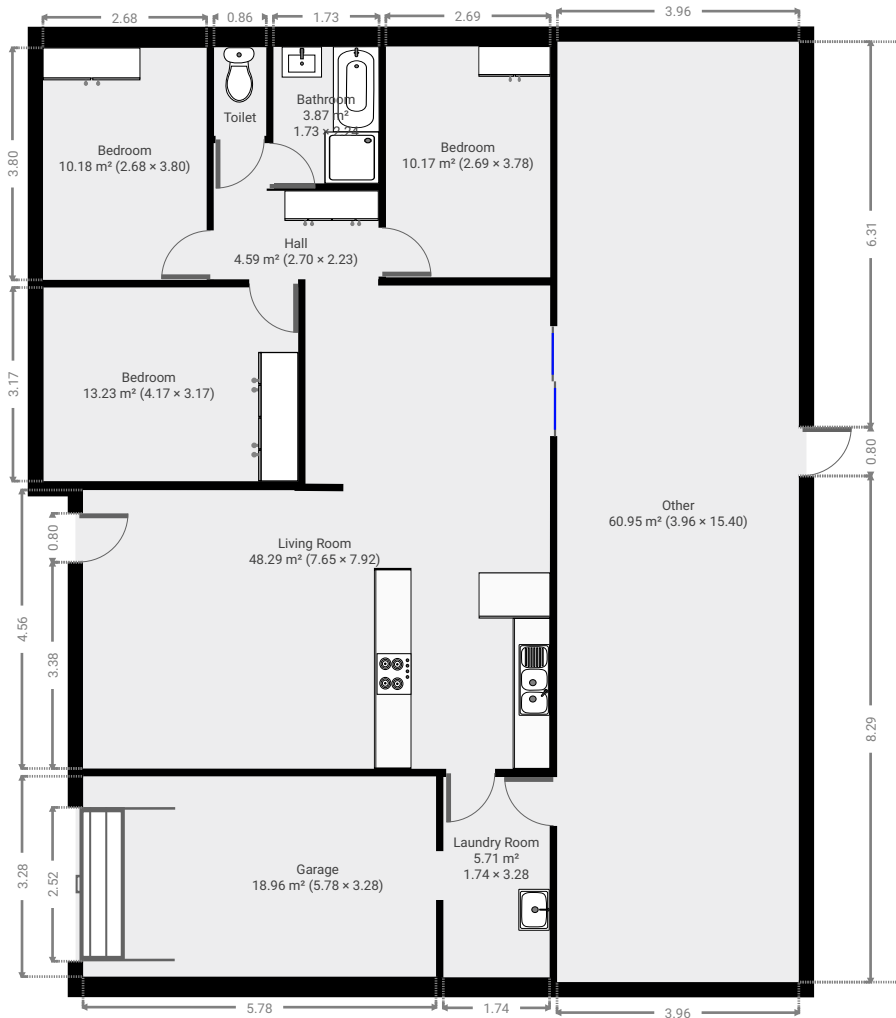

▼ Bathroom
Ground Floor

WIDTH: 2.24 m • LENGTH: 1.73 m
AREA: 3.87 m² • PERIMETER: 7.93 m

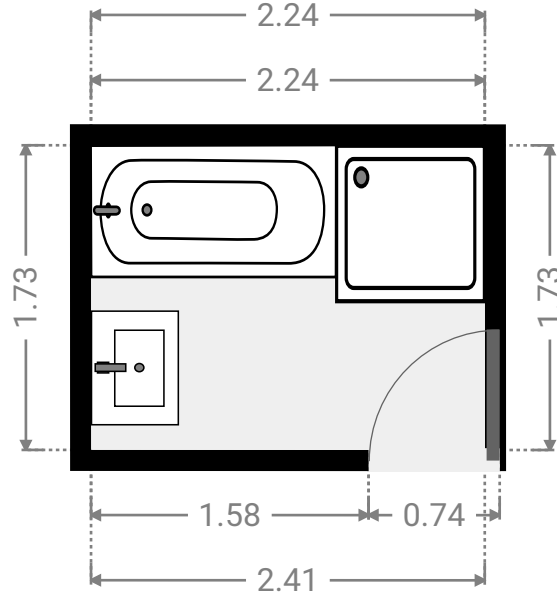

▼ Bedroom
Ground Floor

WIDTH: 3.78 m • LENGTH: 2.69 m
AREA: 10.17 m² • PERIMETER: 12.94 m

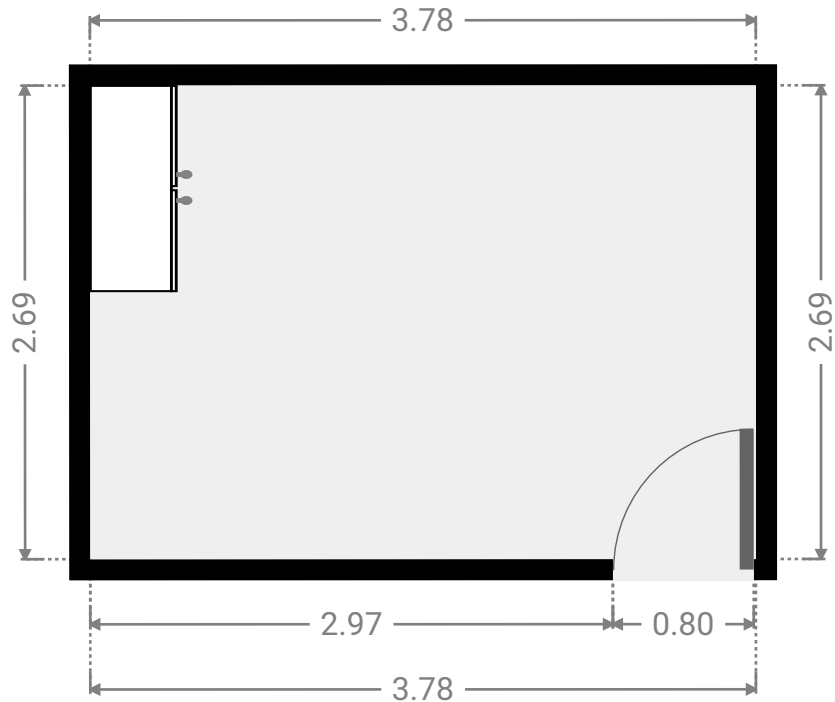

FLOORS: 1

▼ Bedroom
Ground Floor

WIDTH: 3.17 m • LENGTH: 4.17 m
AREA: 13.23 m² • PERIMETER: 14.68 m

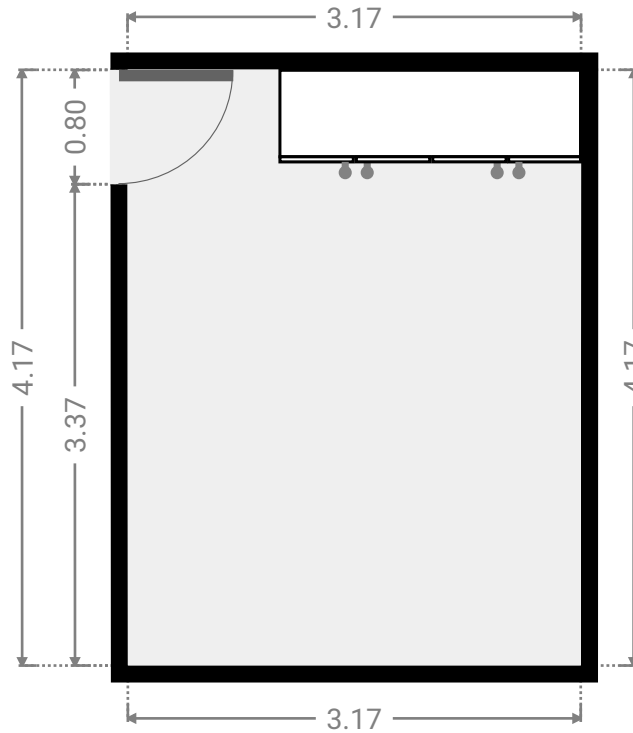

▼ Bedroom
Ground Floor

WIDTH: 3.80 m • LENGTH: 2.68 m
AREA: 10.18 m² • PERIMETER: 12.96 m

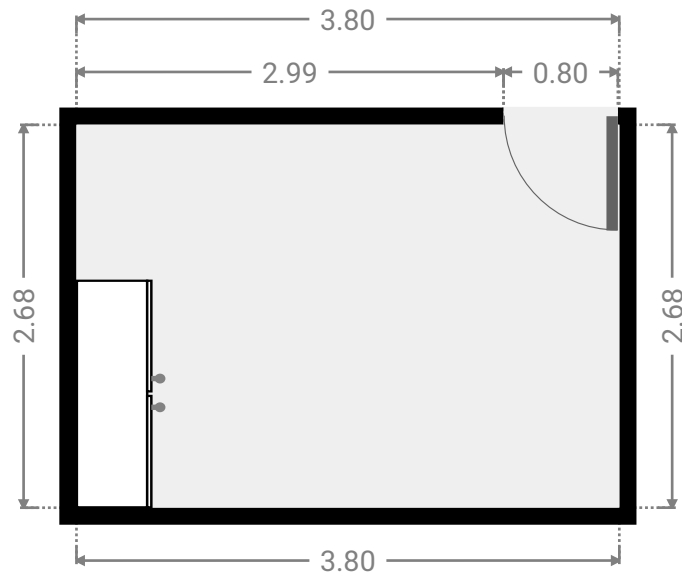
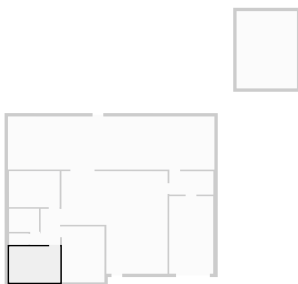

FLOORS: 1

▼ **Garage**
Ground Floor

WIDTH: 3.28 m • LENGTH: 5.78 m
AREA: 18.96 m² • PERIMETER: 18.12 m

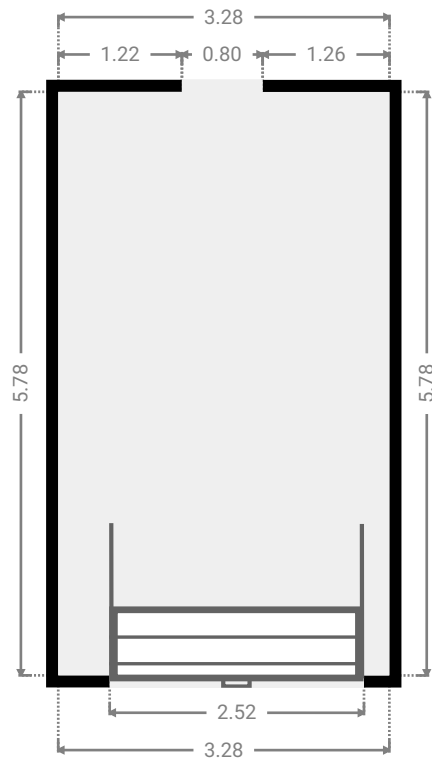
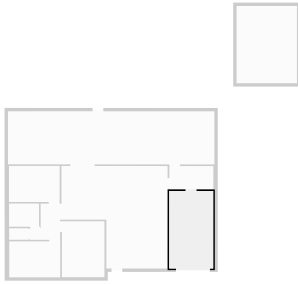

▼ **Hall**
Ground Floor

WIDTH: 2.23 m • LENGTH: 2.70 m
AREA: 4.59 m² • PERIMETER: 9.86 m

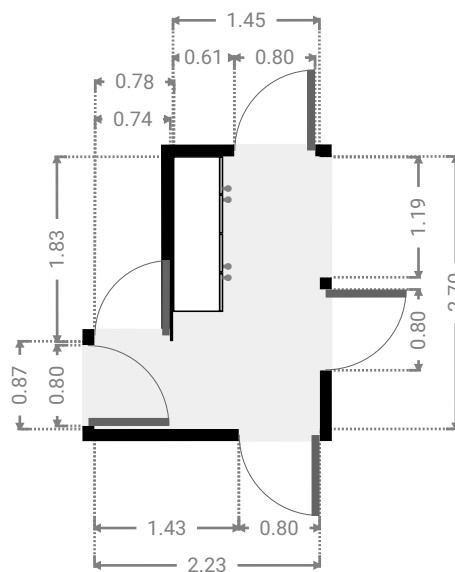

▼ **Laundry Room**
Ground Floor

WIDTH: 3.28 m • LENGTH: 1.74 m
AREA: 5.71 m² • PERIMETER: 10.04 m

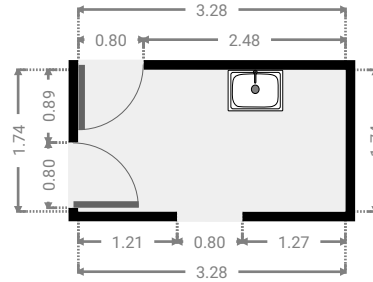
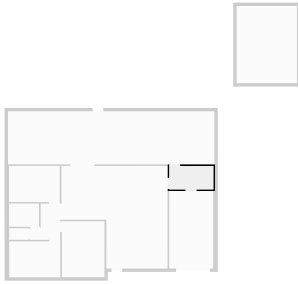

▼ **Living Room**
Ground Floor

WIDTH: 7.92 m • LENGTH: 7.65 m
AREA: 48.29 m² • PERIMETER: 31.12 m

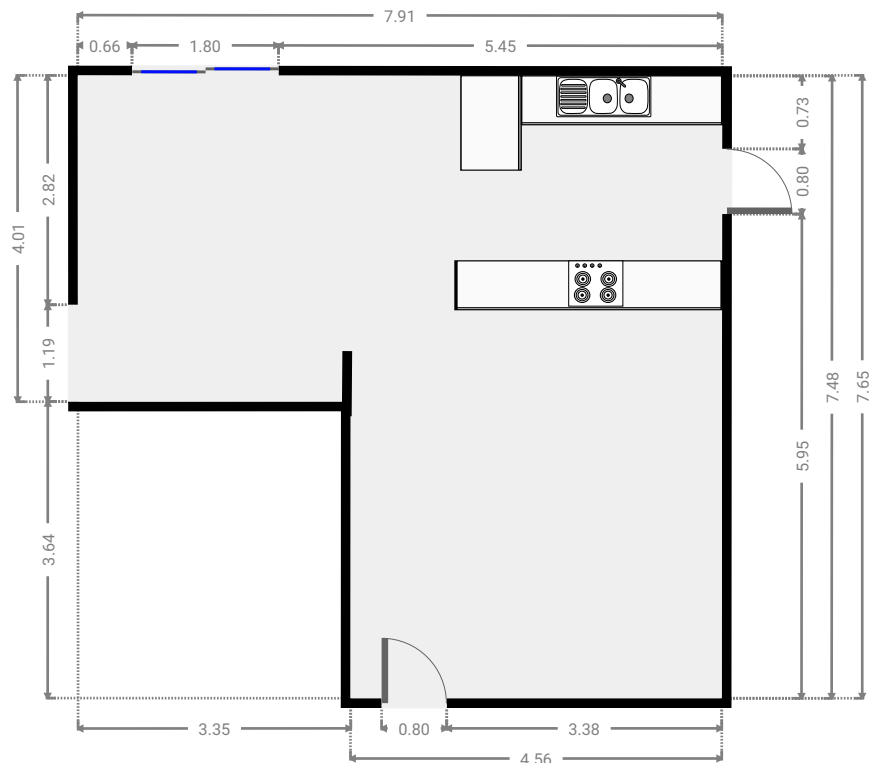
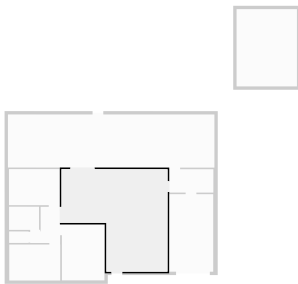

FLOORS: 1

▼ **Other**
Ground Floor

WIDTH: 15.40 m • LENGTH: 3.96 m
AREA: 60.95 m² • PERIMETER: 38.72 m

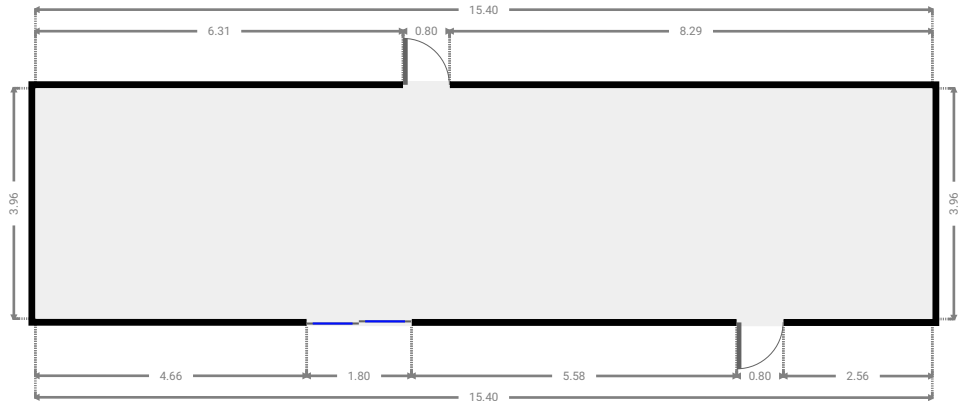
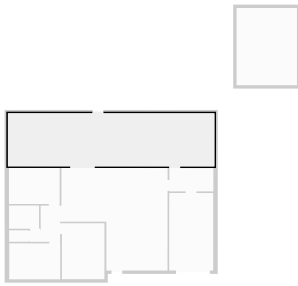

▼ **Other**
Ground Floor

WIDTH: 4.50 m • LENGTH: 5.76 m
AREA: 25.92 m² • PERIMETER: 20.52 m

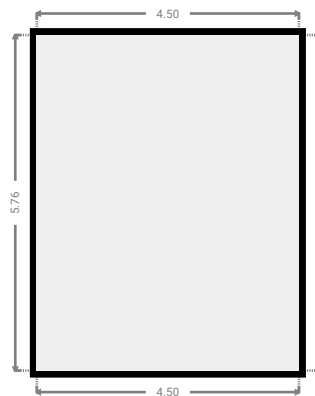
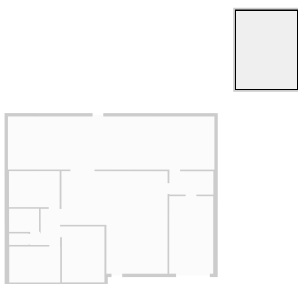

▼ Toilet
Ground Floor

WIDTH: 1.45 m • LENGTH: 0.86 m
AREA: 1.24 m² • PERIMETER: 4.61 m

