

51195 Burnett Highway

SUBMITTED BY
Ray White Rockhampton Casey
stockers@cqoz.com

CREATED ON
2022-01-10

Floors
2

▼ Ground Floor

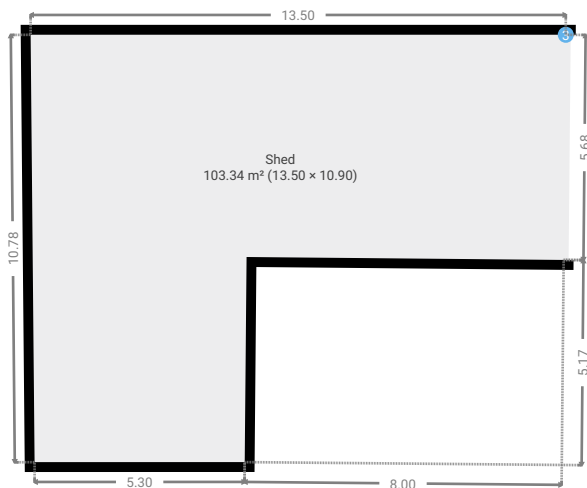
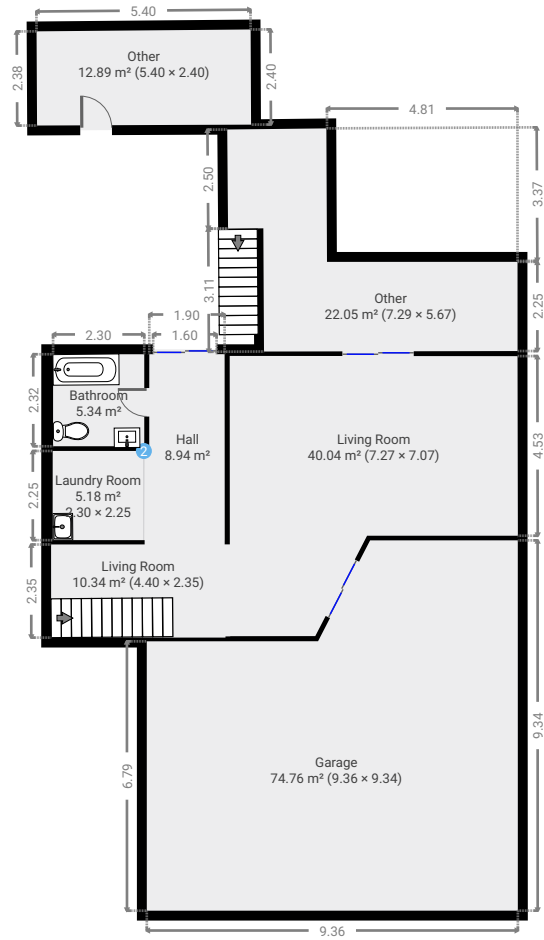

FLOORS: 2

▼ **Living Room**
Ground Floor

WIDTH: 7.27 m • LENGTH: 7.07 m
AREA: 40.04 m² • PERIMETER: 27.67 m

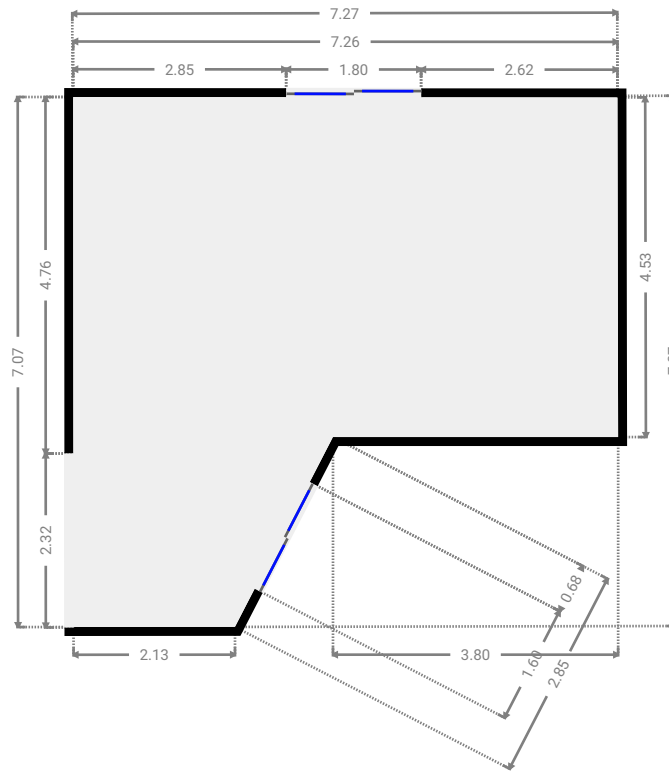
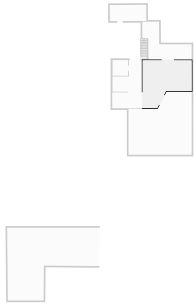

▼ **Living Room**
Ground Floor

WIDTH: 4.40 m • LENGTH: 2.35 m
AREA: 10.34 m² • PERIMETER: 13.50 m

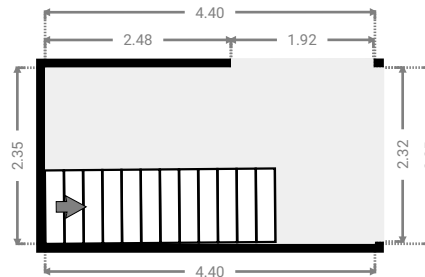
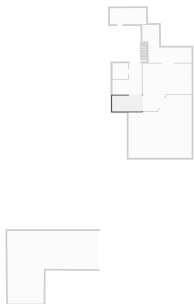

▼ **Hall**
Ground Floor

WIDTH: 1.91 m • LENGTH: 4.70 m
AREA: 8.94 m² • PERIMETER: 13.21 m

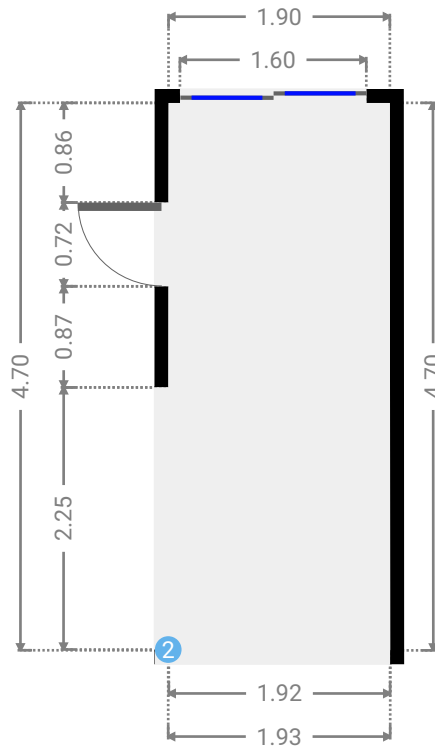

▼ **Laundry Room**
Ground Floor

WIDTH: 2.30 m • LENGTH: 2.25 m
AREA: 5.18 m² • PERIMETER: 9.10 m

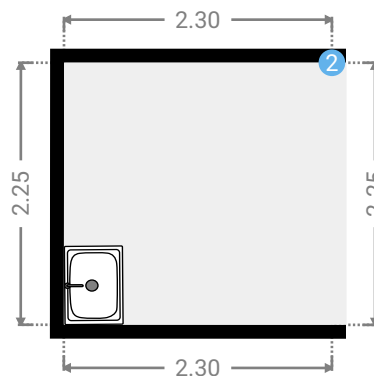
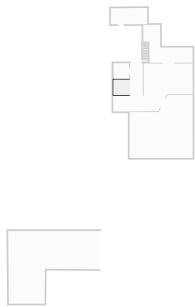

▼ Laundry Room/Ground Floor

2 OPENING

Height
0.00 m



▼ **Bathroom**
Ground Floor

WIDTH: 2.30 m • LENGTH: 2.32 m
AREA: 5.34 m² • PERIMETER: 9.24 m

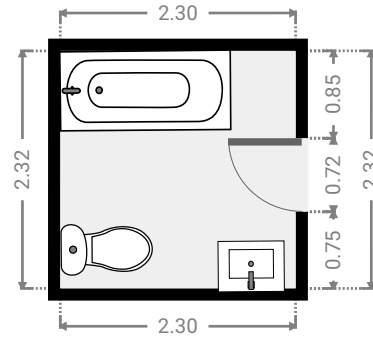
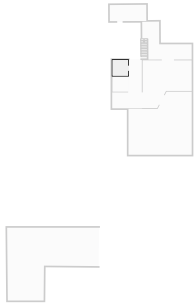

▼ **Other**
Ground Floor

WIDTH: 7.29 m • LENGTH: 5.67 m
AREA: 22.05 m² • PERIMETER: 25.82 m

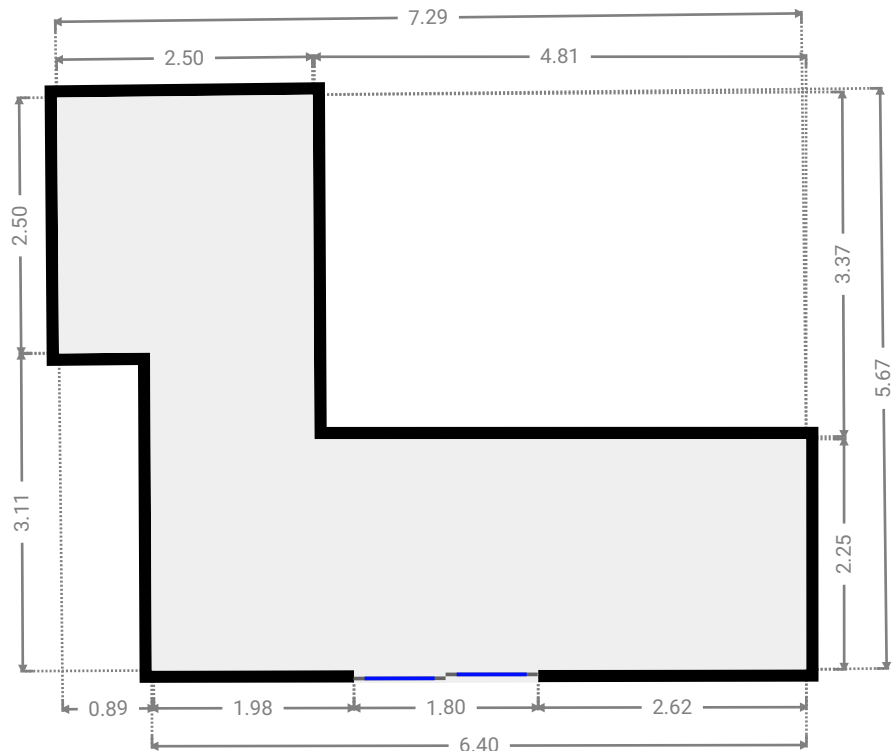
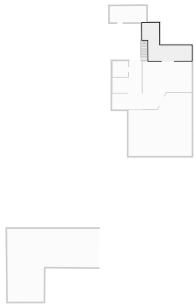

FLOORS: 2

▼ **Other**
Ground Floor

WIDTH: 5.40 m • LENGTH: 2.40 m
AREA: 12.89 m² • PERIMETER: 15.57 m

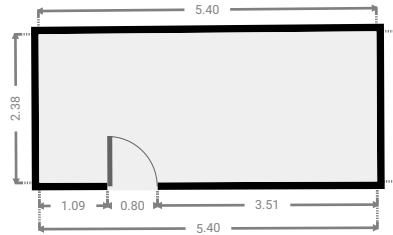

▼ **Garage**
Ground Floor

WIDTH: 9.36 m • LENGTH: 9.34 m
AREA: 74.76 m² • PERIMETER: 36.40 m

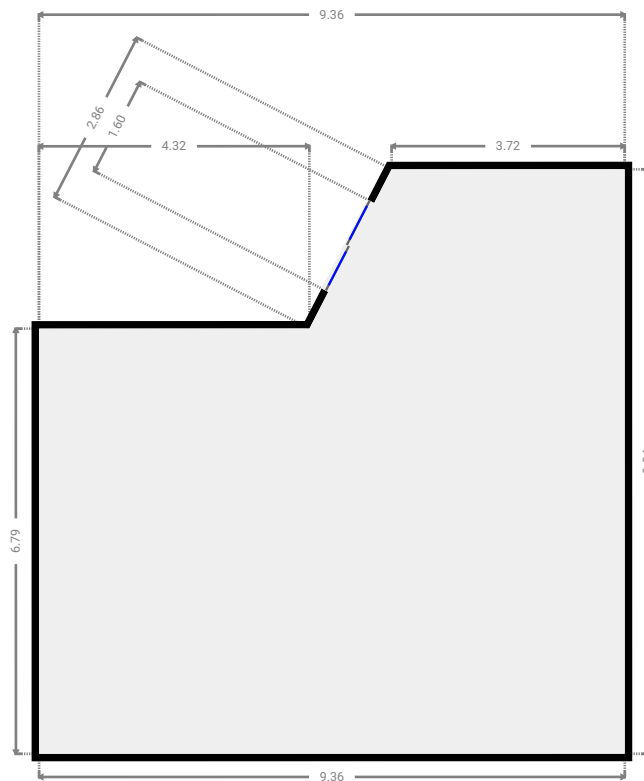
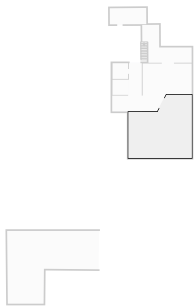

FLOORS: 2

▼ **Shed**
Ground Floor

WIDTH: 13.50 m • LENGTH: 10.90 m
AREA: 103.34 m² • PERIMETER: 48.43 m

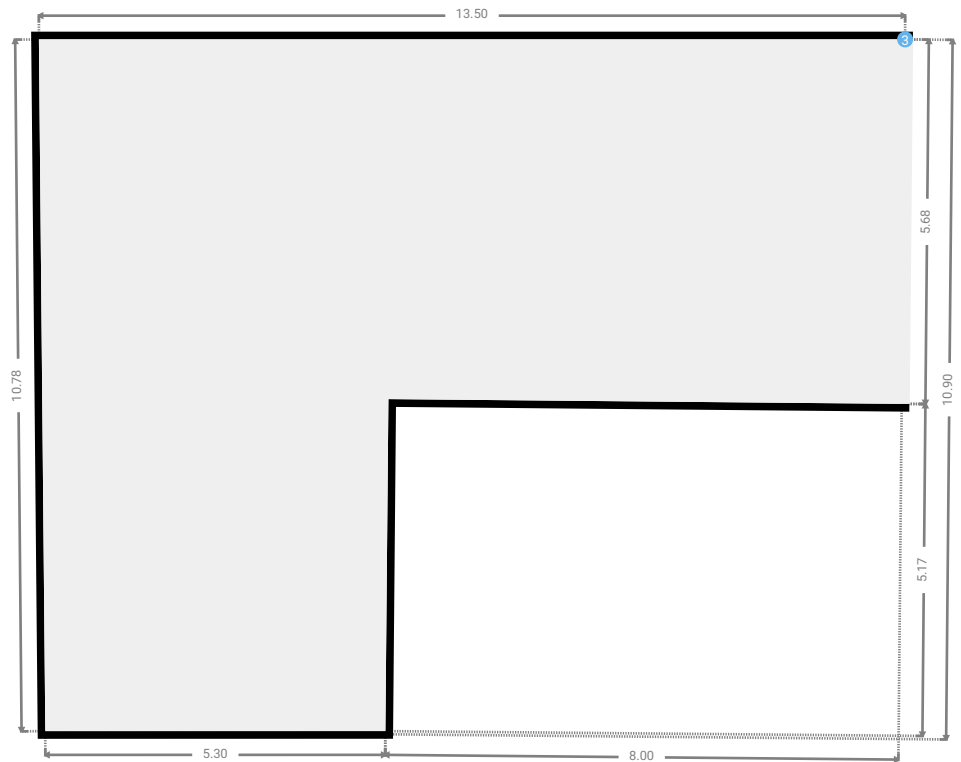
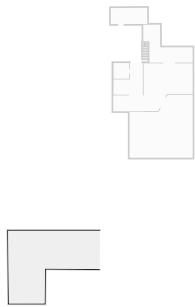

▼ **Shed/Ground Floor**

3 OPENING

Height
0.00 m



▼ 1st Floor

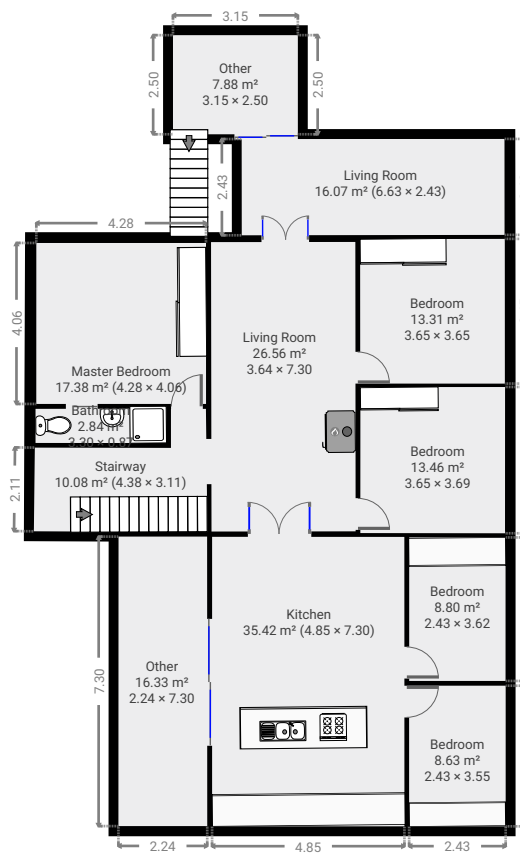

▼ Living Room
1st Floor

WIDTH: 3.64 m • LENGTH: 7.30 m
AREA: 26.56 m² • PERIMETER: 21.88 m

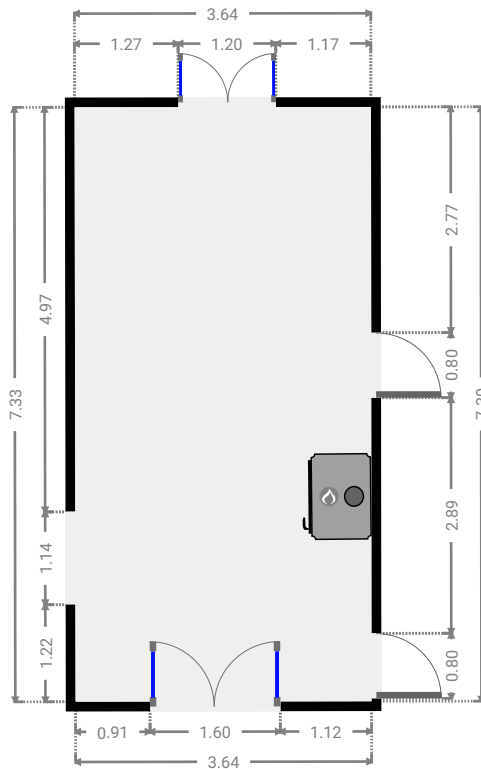
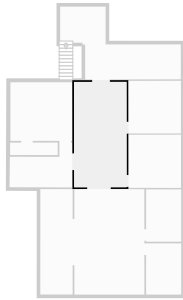

▼ Stairway
1st Floor

WIDTH: 4.38 m • LENGTH: 3.11 m
AREA: 10.08 m² • PERIMETER: 14.89 m

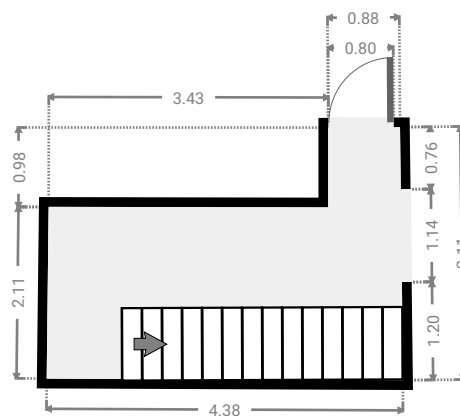
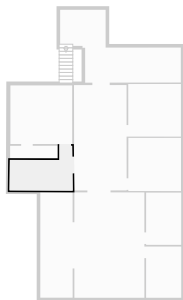

▼ **Master Bedroom**
1st Floor

WIDTH: 4.28 m • LENGTH: 4.06 m
AREA: 17.38 m² • PERIMETER: 16.68 m

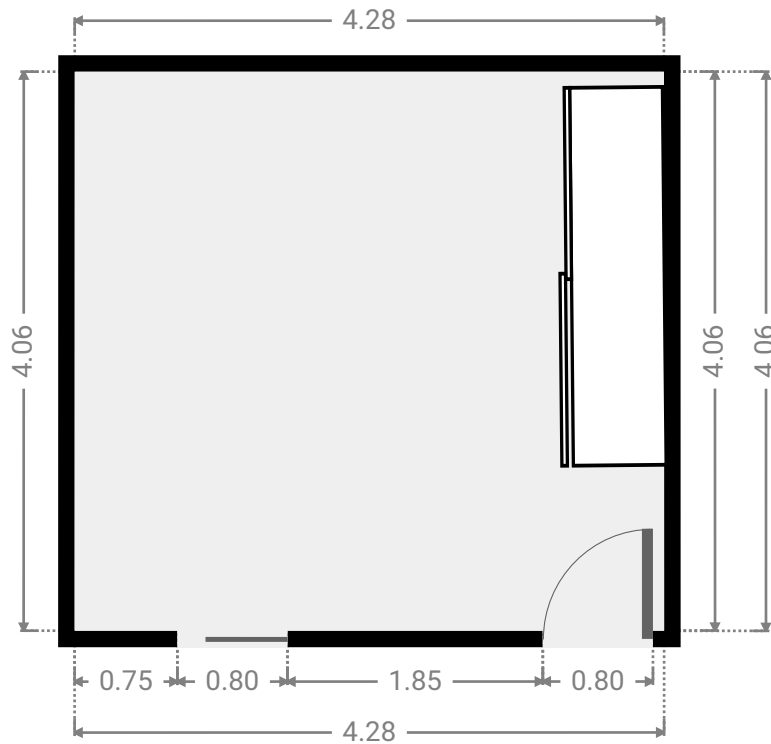
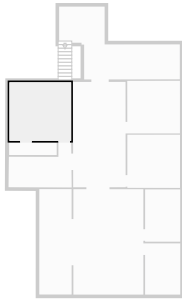

▼ **Bathroom**
1st Floor

WIDTH: 3.30 m • LENGTH: 0.87 m
AREA: 2.84 m² • PERIMETER: 8.32 m

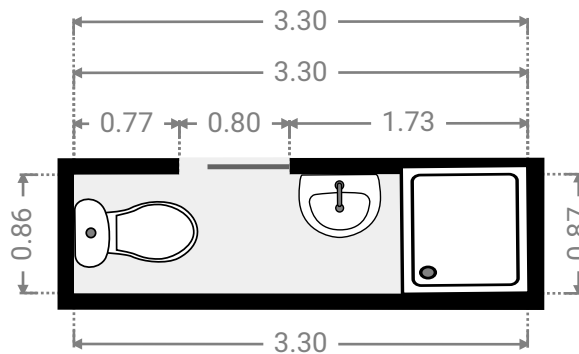
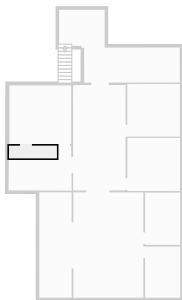

▼ **Living Room**
1st Floor

WIDTH: 6.63 m • LENGTH: 2.43 m
AREA: 16.07 m² • PERIMETER: 18.11 m

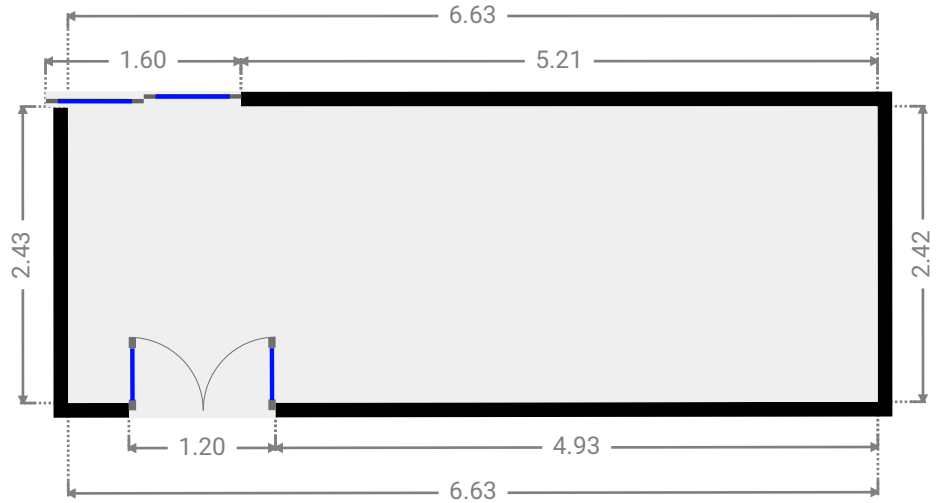
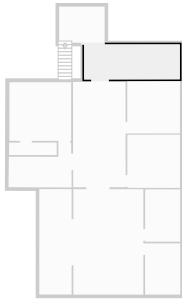

▼ **Bedroom**
1st Floor

WIDTH: 3.65 m • LENGTH: 3.65 m
AREA: 13.31 m² • PERIMETER: 14.59 m

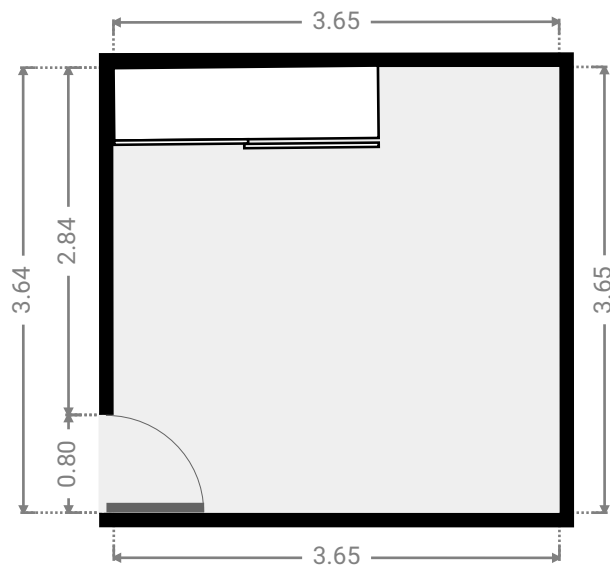
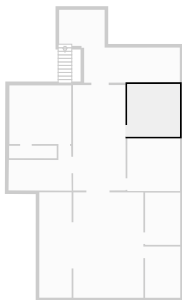

▼ **Bedroom**
1st Floor

WIDTH: 3.65 m • LENGTH: 3.69 m
AREA: 13.46 m² • PERIMETER: 14.67 m

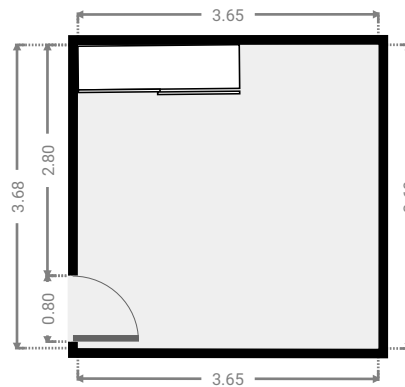
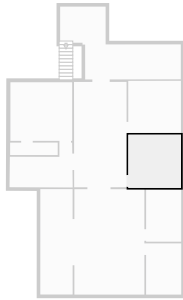

▼ **Kitchen**
1st Floor

WIDTH: 4.85 m • LENGTH: 7.30 m
AREA: 35.42 m² • PERIMETER: 24.30 m

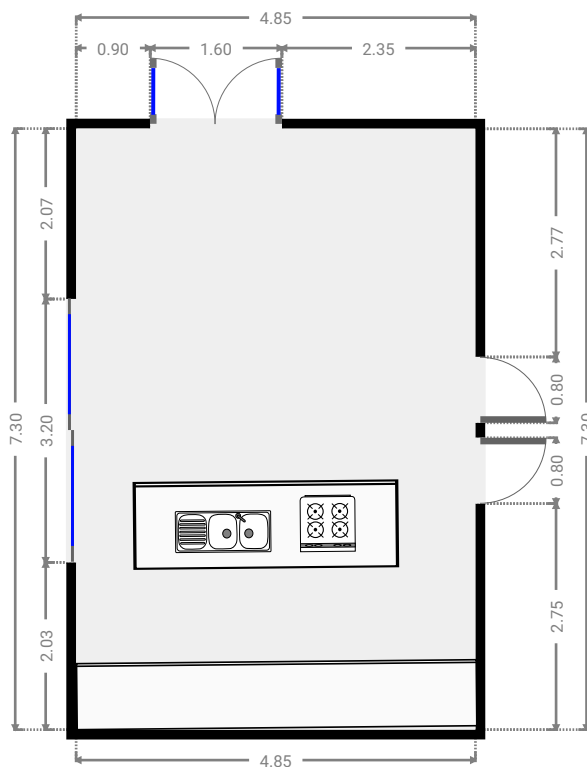
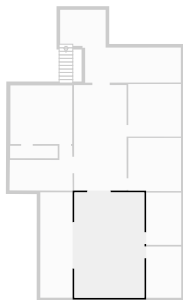

▼ **Bedroom**
1st Floor

WIDTH: 2.43 m • LENGTH: 3.62 m
AREA: 8.80 m² • PERIMETER: 12.10 m

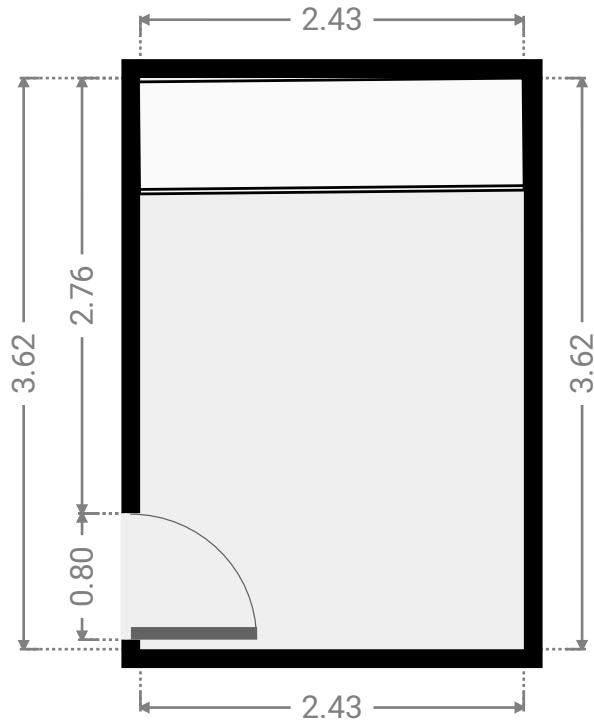
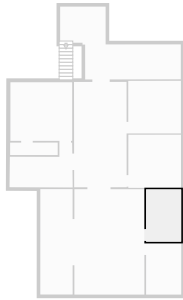

▼ **Bedroom**
1st Floor

WIDTH: 2.43 m • LENGTH: 3.55 m
AREA: 8.63 m² • PERIMETER: 11.96 m

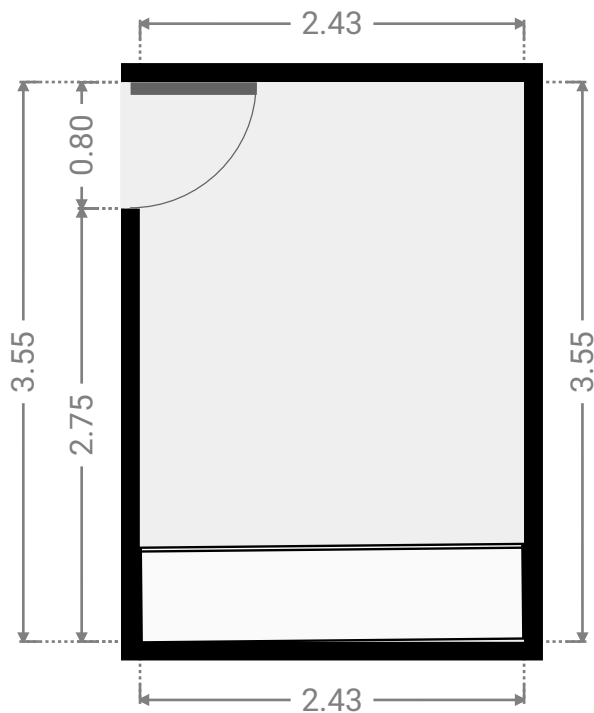
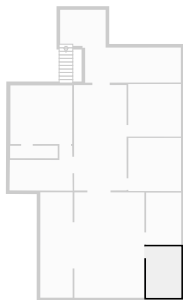

▼ Other
1st Floor

WIDTH: 2.24 m • LENGTH: 7.30 m
AREA: 16.33 m² • PERIMETER: 19.08 m

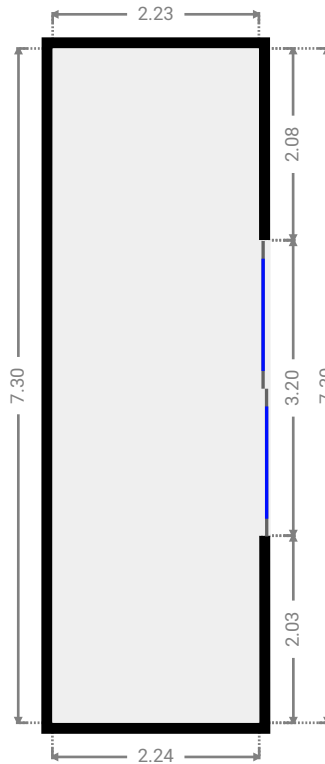
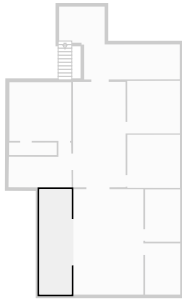

▼ Other
1st Floor

WIDTH: 3.15 m • LENGTH: 2.50 m
AREA: 7.88 m² • PERIMETER: 11.30 m

