

# 5 Tooker Street

Created on  
2021-09-09

Floors  
1

▼ Ground Floor

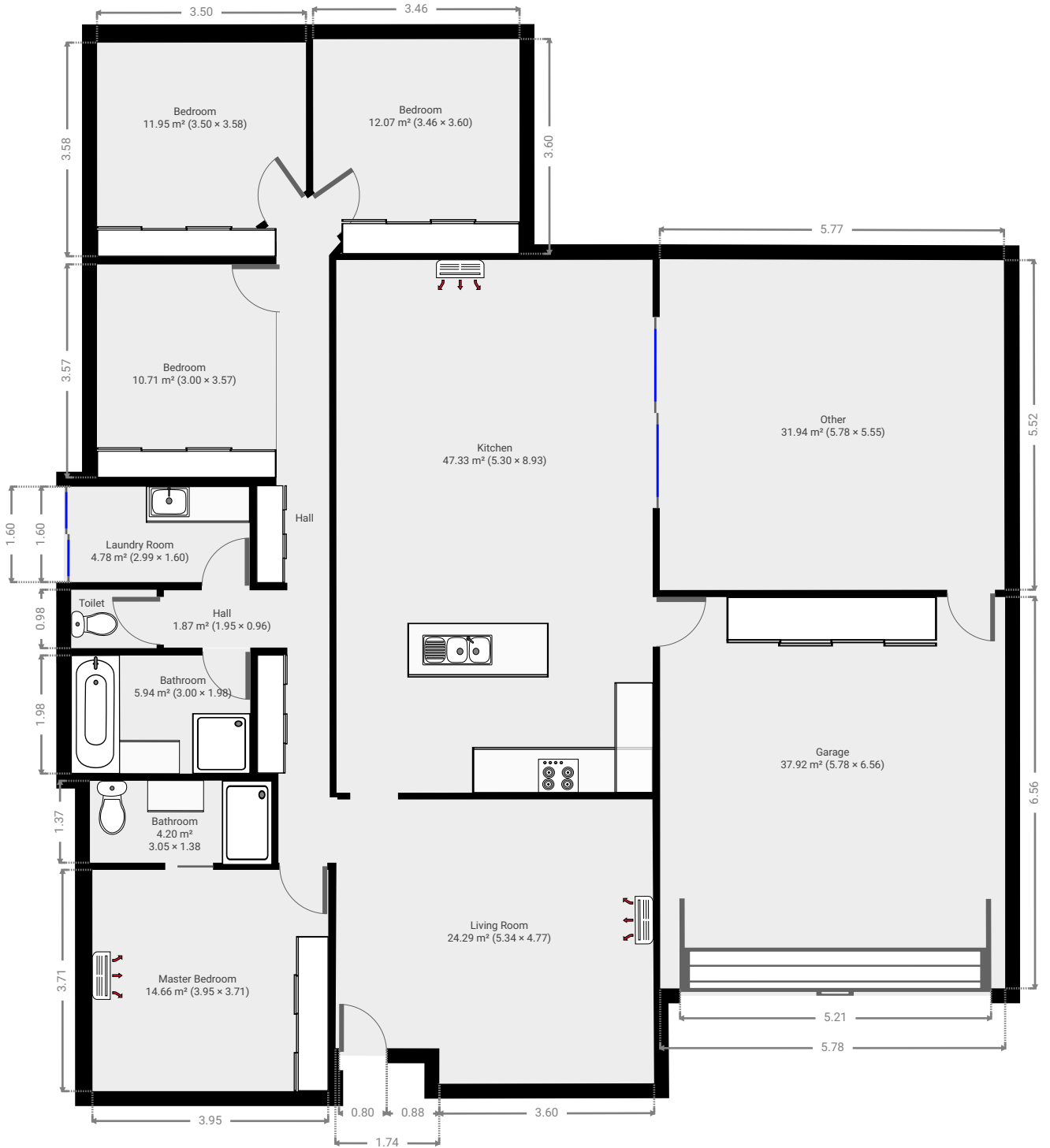

▼ Living Room  
Ground Floor

WIDTH: 5.34 m • LENGTH: 4.77 m  
AREA: 24.29 m<sup>2</sup> • PERIMETER: 20.15 m

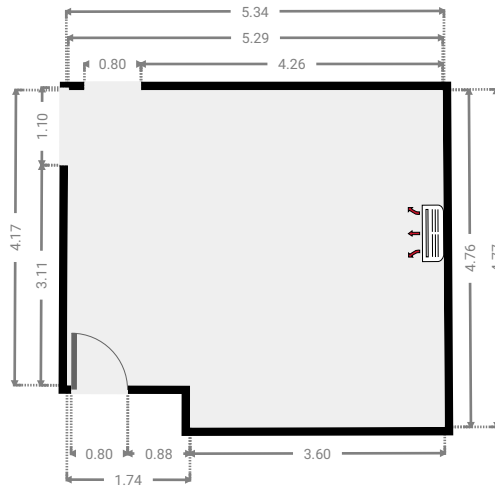
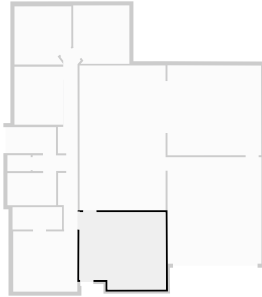

▼ Kitchen  
Ground Floor

WIDTH: 5.30 m • LENGTH: 8.93 m  
AREA: 47.33 m<sup>2</sup> • PERIMETER: 28.46 m

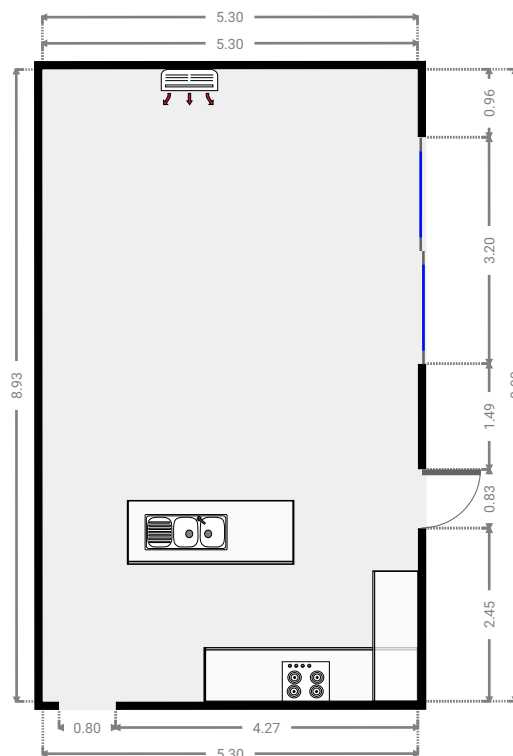
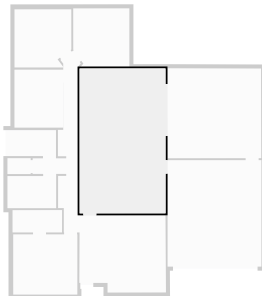

▼ **Garage**  
Ground Floor

WIDTH: 5.78 m • LENGTH: 6.56 m  
AREA: 37.92 m<sup>2</sup> • PERIMETER: 24.68 m

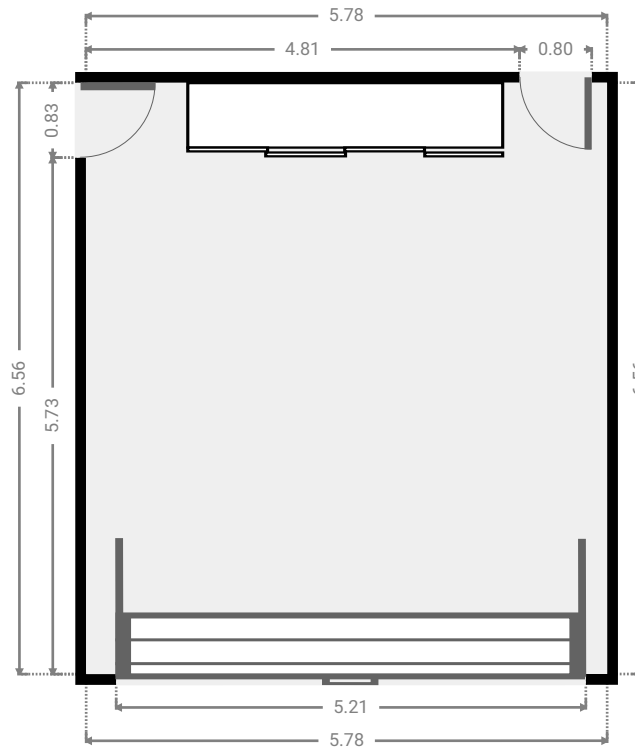
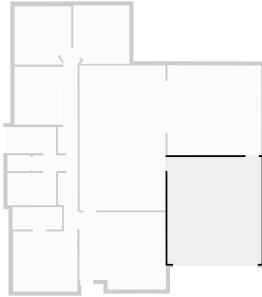

▼ **Other**  
Ground Floor

WIDTH: 5.78 m • LENGTH: 5.55 m  
AREA: 31.94 m<sup>2</sup> • PERIMETER: 22.61 m

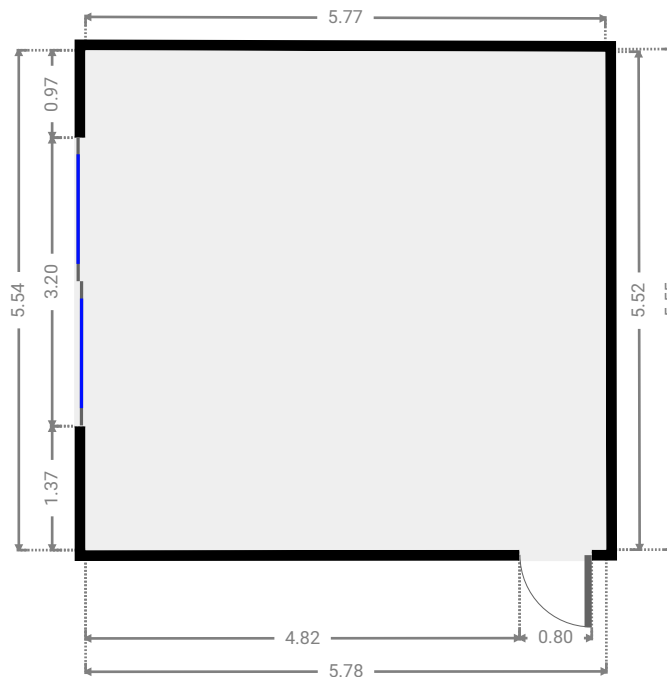
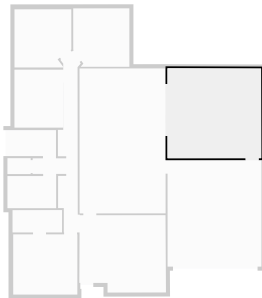

▼ **Hall**  
Ground Floor

WIDTH: 1.41 m • LENGTH: 11.16 m  
AREA: 10.68 m<sup>2</sup> • PERIMETER: 25.54 m

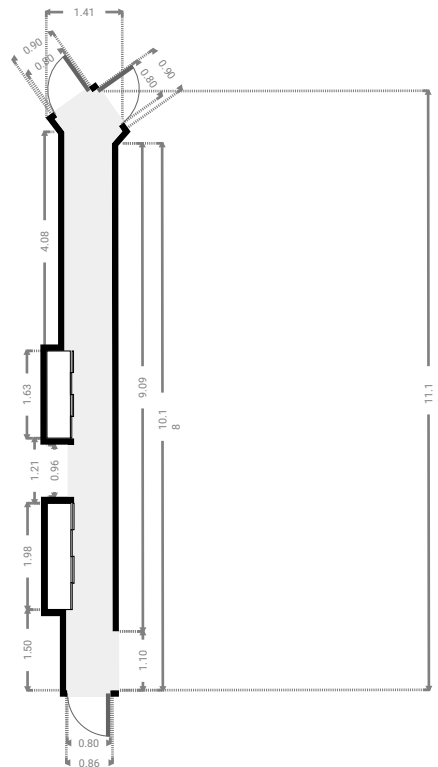
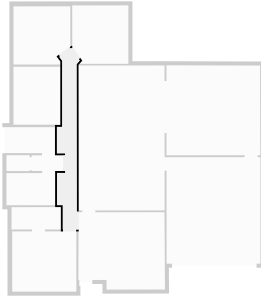

▼ **Bedroom**  
Ground Floor

WIDTH: 3.46 m • LENGTH: 3.60 m  
AREA: 12.07 m<sup>2</sup> • PERIMETER: 13.93 m

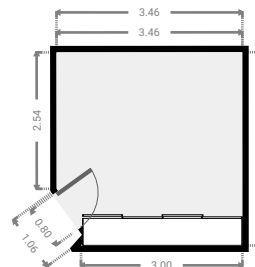
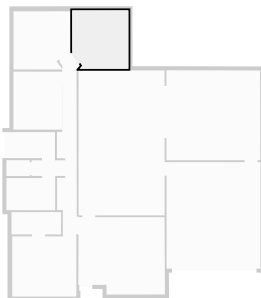

▼ **Bedroom**  
Ground Floor

WIDTH: 3.50 m • LENGTH: 3.58 m  
AREA: 11.95 m<sup>2</sup> • PERIMETER: 14.21 m

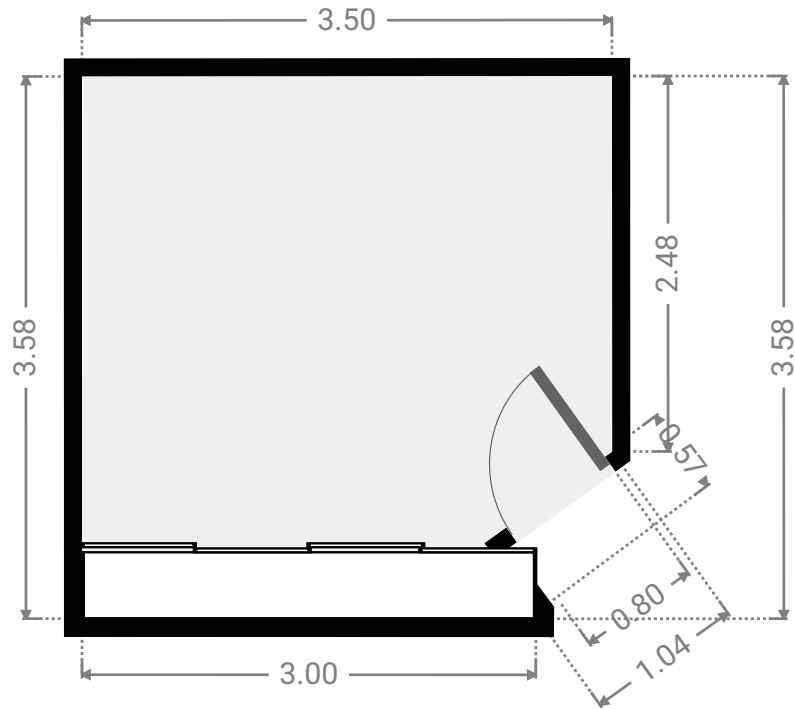
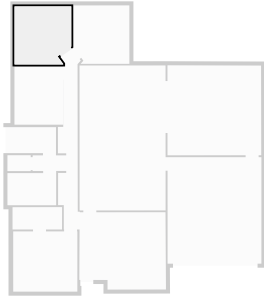

▼ **Bedroom**  
Ground Floor

WIDTH: 3.00 m • LENGTH: 3.57 m  
AREA: 10.71 m<sup>2</sup> • PERIMETER: 13.14 m

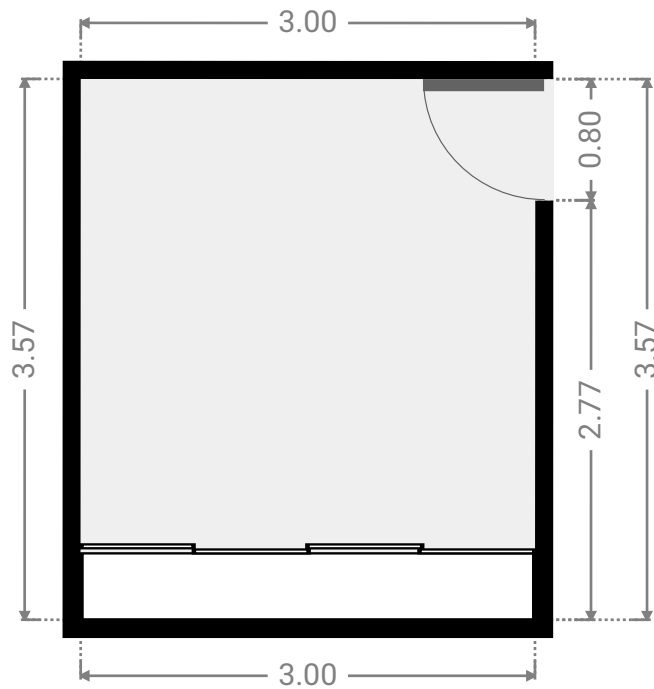
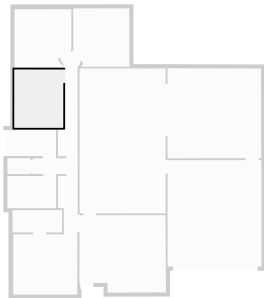

▼ Laundry Room  
Ground Floor

WIDTH: 2.99 m • LENGTH: 1.60 m  
AREA: 4.78 m<sup>2</sup> • PERIMETER: 9.18 m

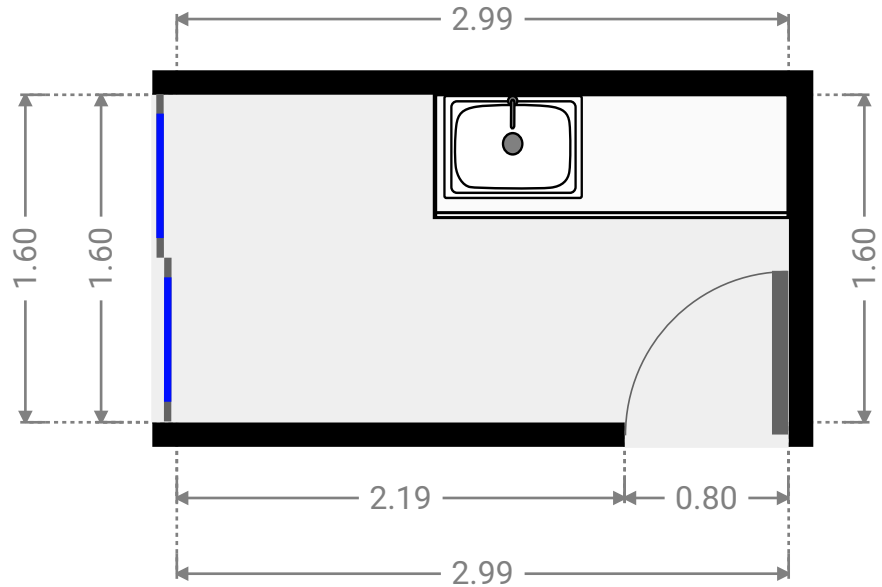
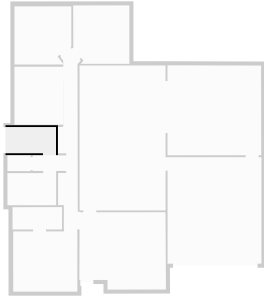

▼ Hall  
Ground Floor

WIDTH: 1.95 m • LENGTH: 0.96 m  
AREA: 1.87 m<sup>2</sup> • PERIMETER: 5.82 m

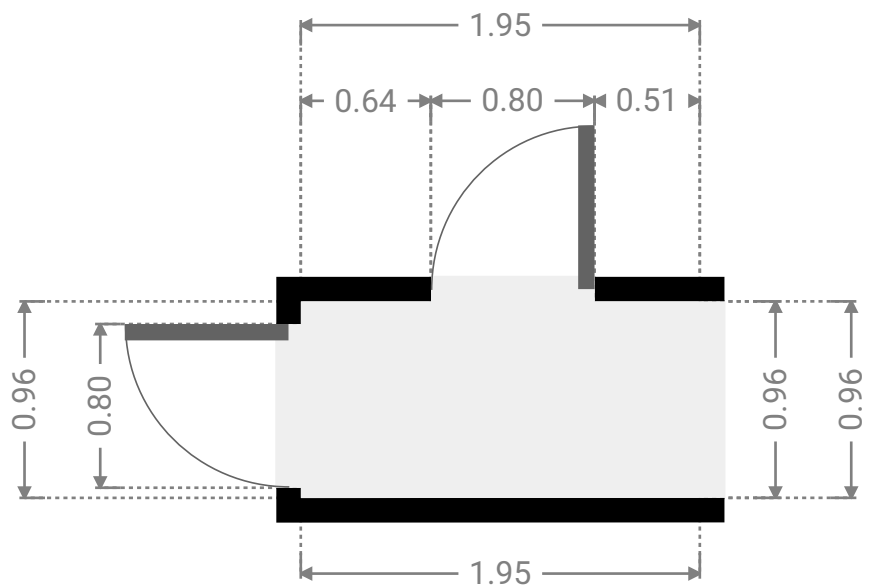
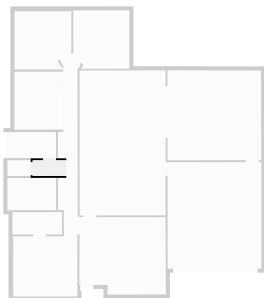

▼ Toilet  
Ground Floor

WIDTH: 1.43 m • LENGTH: 0.98 m  
AREA: 1.40 m<sup>2</sup> • PERIMETER: 4.82 m

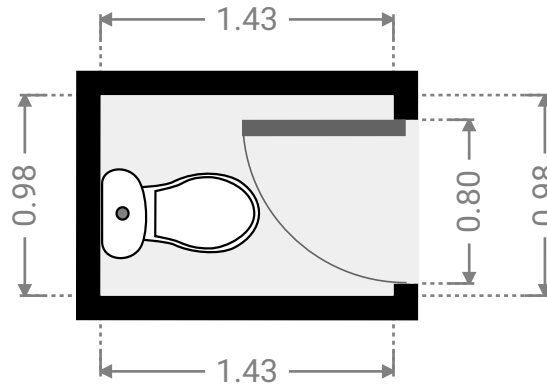
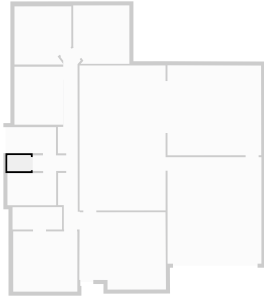

▼ Bathroom  
Ground Floor

WIDTH: 3.00 m • LENGTH: 1.98 m  
AREA: 5.94 m<sup>2</sup> • PERIMETER: 9.96 m

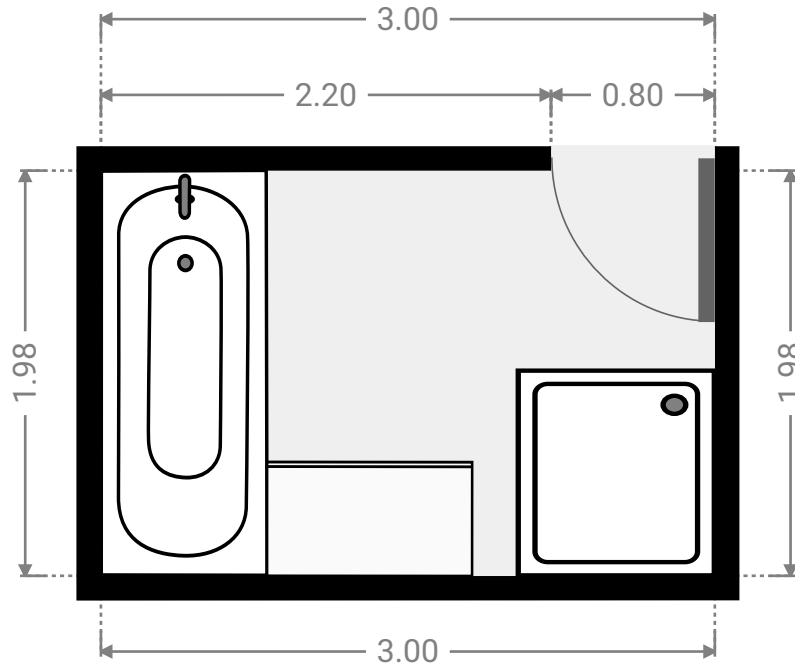
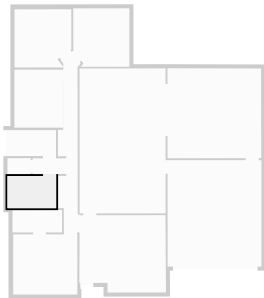



▼ **Master Bedroom**  
Ground Floor

WIDTH: 3.95 m • LENGTH: 3.71 m  
AREA: 14.66 m<sup>2</sup> • PERIMETER: 15.32 m

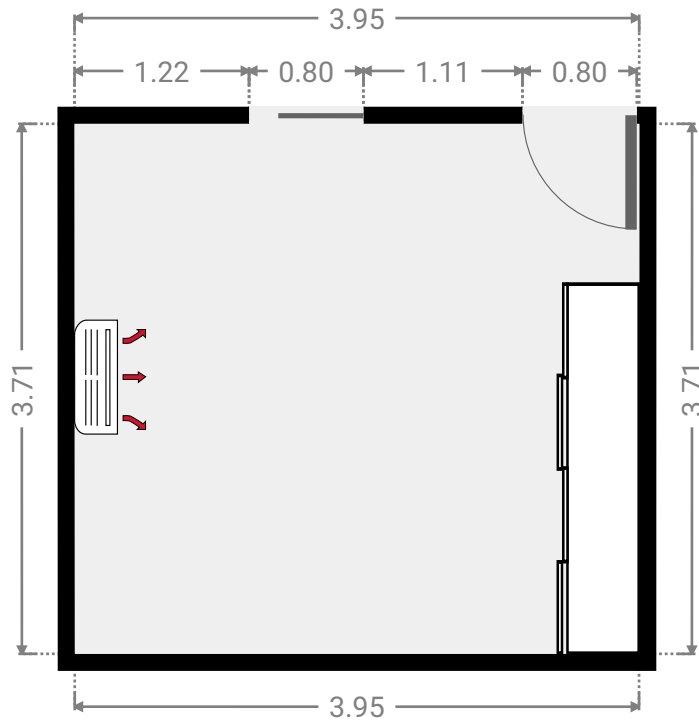
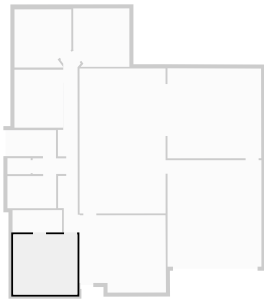

▼ **Bathroom**  
Ground Floor

WIDTH: 3.05 m • LENGTH: 1.38 m  
AREA: 4.20 m<sup>2</sup> • PERIMETER: 8.85 m

