

# 5 Davey Avenue

**SUBMITTED BY**  
Ray White Rockhampton Casey  
stockers@cqoz.com

---

**CREATED ON**  
2022-10-12

---

**Floors**  
1

---

## ▼ Ground Floor



▼ **Bathroom**  
Ground Floor

WIDTH: 1.79 m • LENGTH: 2.12 m  
AREA: 3.80 m<sup>2</sup> • PERIMETER: 7.82 m

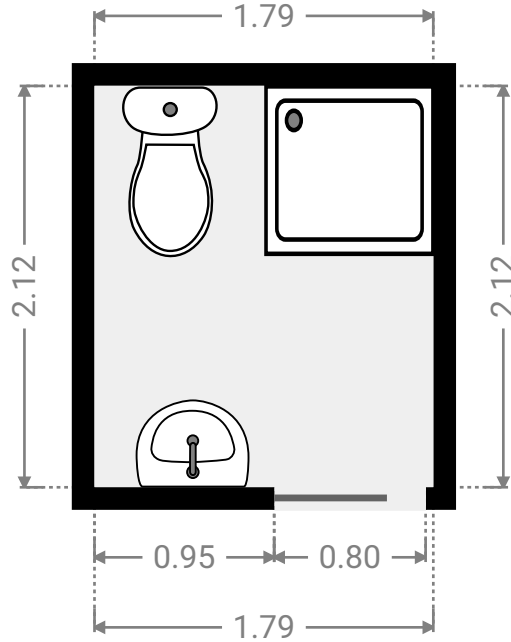
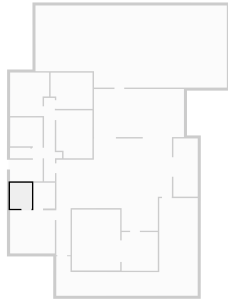

▼ **Bathroom**  
Ground Floor

WIDTH: 2.67 m • LENGTH: 2.37 m  
AREA: 6.31 m<sup>2</sup> • PERIMETER: 10.06 m

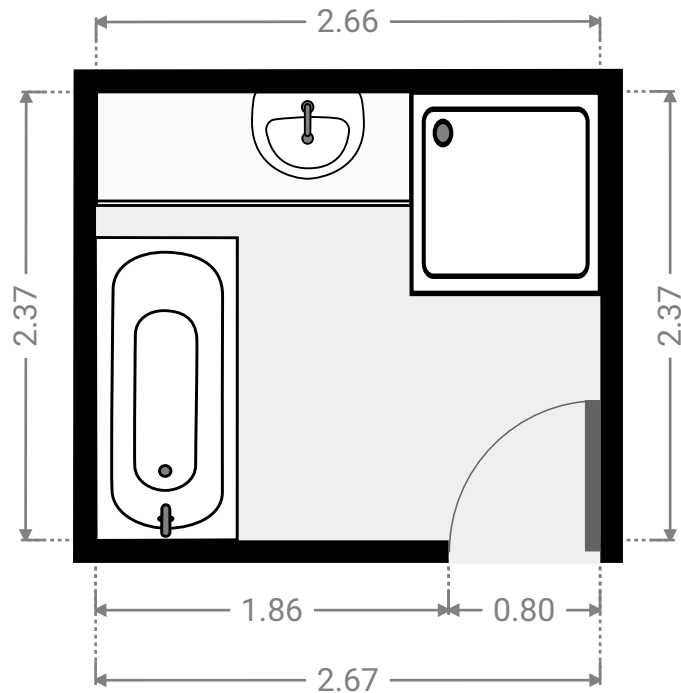
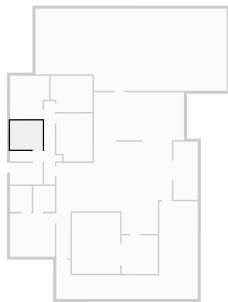

▼ **Bedroom**  
Ground Floor

WIDTH: 3.21 m • LENGTH: 3.58 m  
AREA: 10.60 m<sup>2</sup> • PERIMETER: 13.57 m

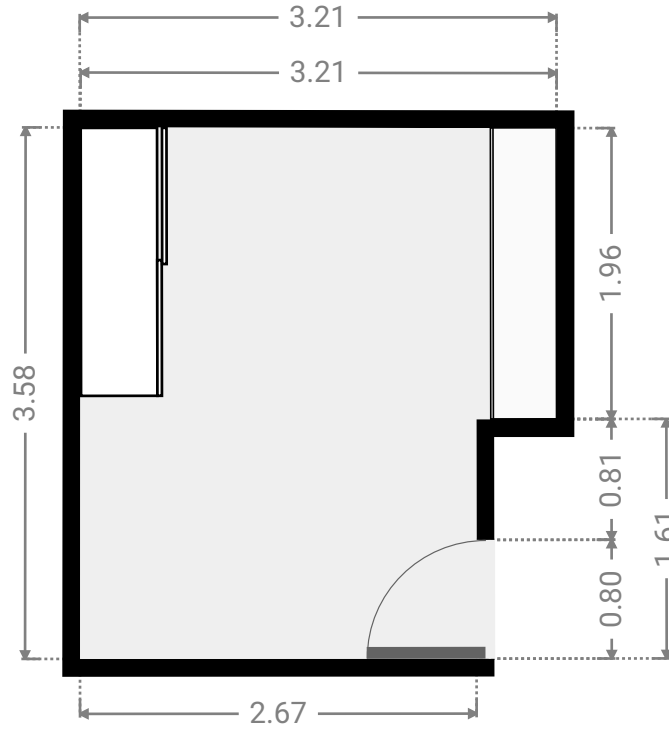
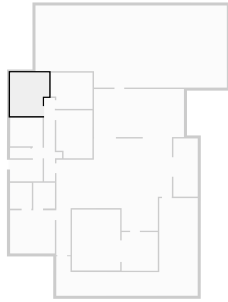

▼ **Bedroom**  
Ground Floor

WIDTH: 3.45 m • LENGTH: 2.98 m  
AREA: 9.79 m<sup>2</sup> • PERIMETER: 12.85 m

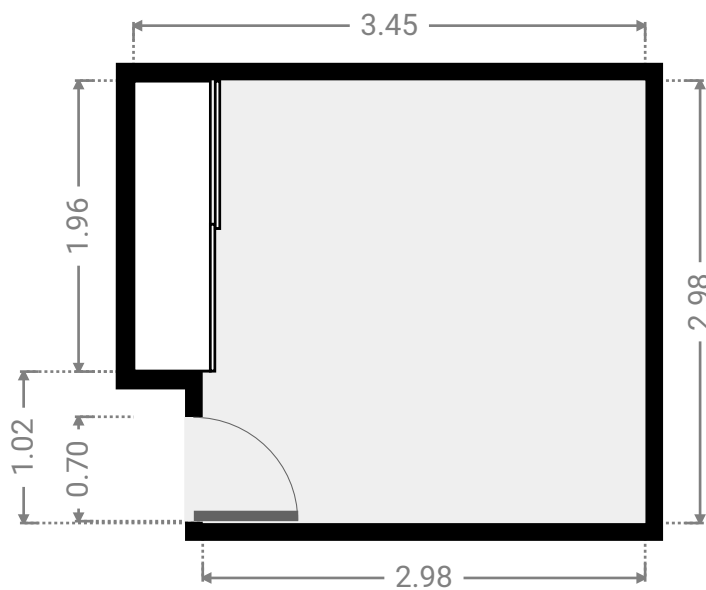
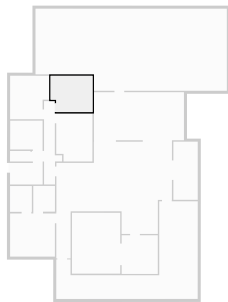

▼ **Bedroom**  
Ground Floor

WIDTH: 2.97 m • LENGTH: 3.94 m  
AREA: 11.34 m<sup>2</sup> • PERIMETER: 13.82 m

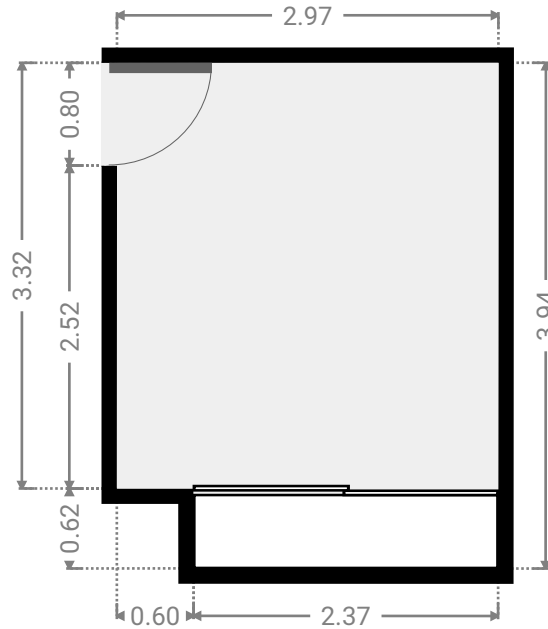
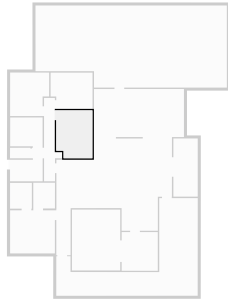

▼ **Bedroom**  
Ground Floor

WIDTH: 2.00 m • LENGTH: 4.78 m  
AREA: 9.56 m<sup>2</sup> • PERIMETER: 13.56 m

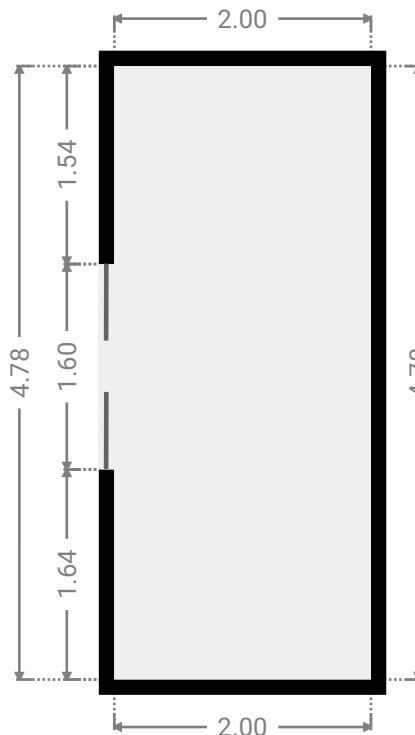
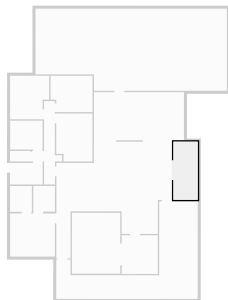

▼ Hall  
Ground Floor

WIDTH: 1.17 m • LENGTH: 3.79 m  
AREA: 4.43 m<sup>2</sup> • PERIMETER: 9.92 m

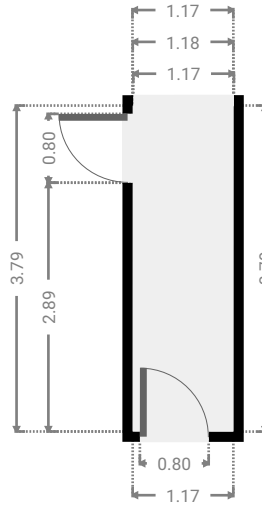
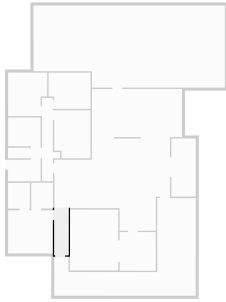

▼ Hall  
Ground Floor

WIDTH: 2.48 m • LENGTH: 6.85 m  
AREA: 7.27 m<sup>2</sup> • PERIMETER: 18.68 m

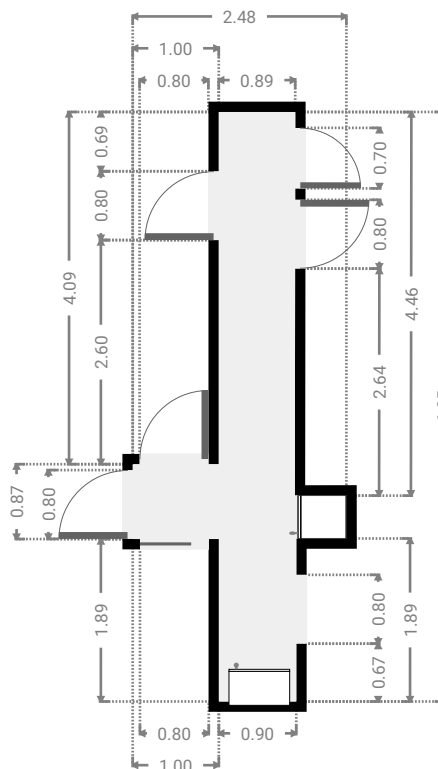
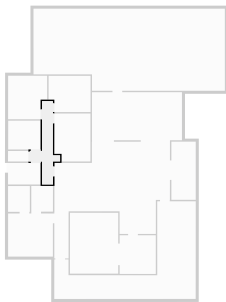

▼ **Laundry Room**  
Ground Floor

WIDTH: 2.68 m • LENGTH: 1.77 m  
AREA: 4.74 m<sup>2</sup> • PERIMETER: 8.90 m

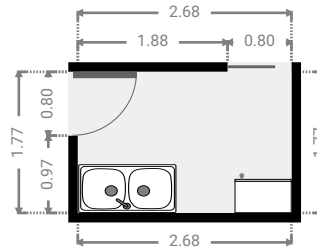
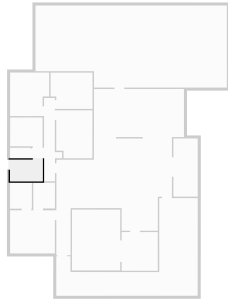

▼ **Living Room**  
Ground Floor

WIDTH: 9.50 m • LENGTH: 7.59 m  
AREA: 53.44 m<sup>2</sup> • PERIMETER: 34.16 m

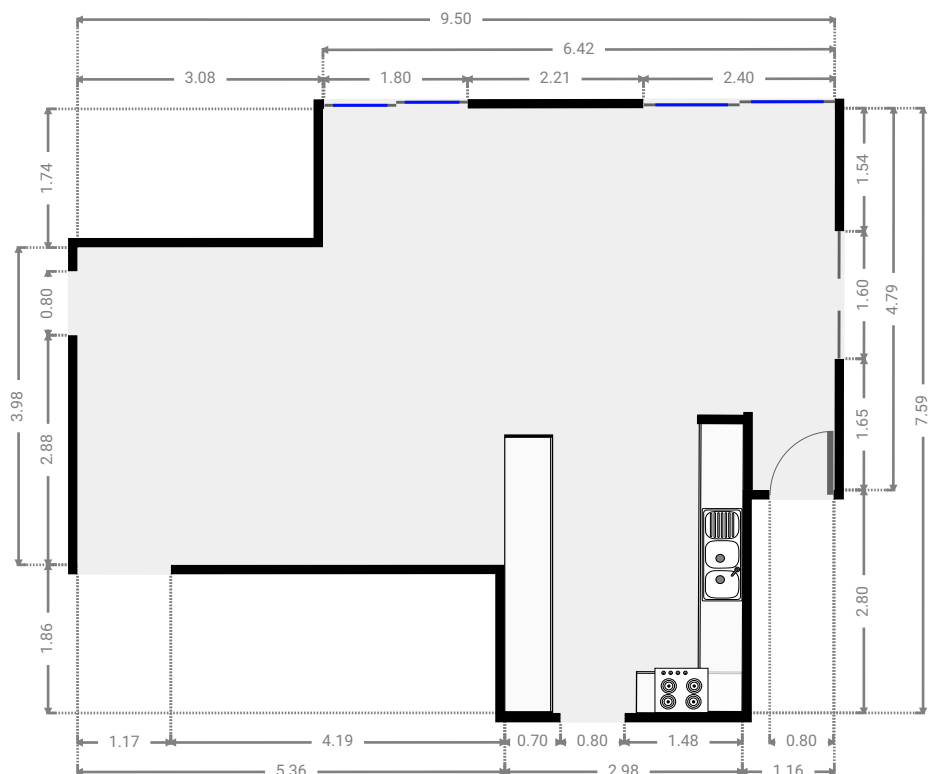
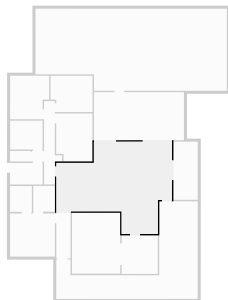

▼ **Living Room**  
Ground Floor

WIDTH: 3.97 m • LENGTH: 5.00 m  
AREA: 19.85 m<sup>2</sup> • PERIMETER: 17.94 m

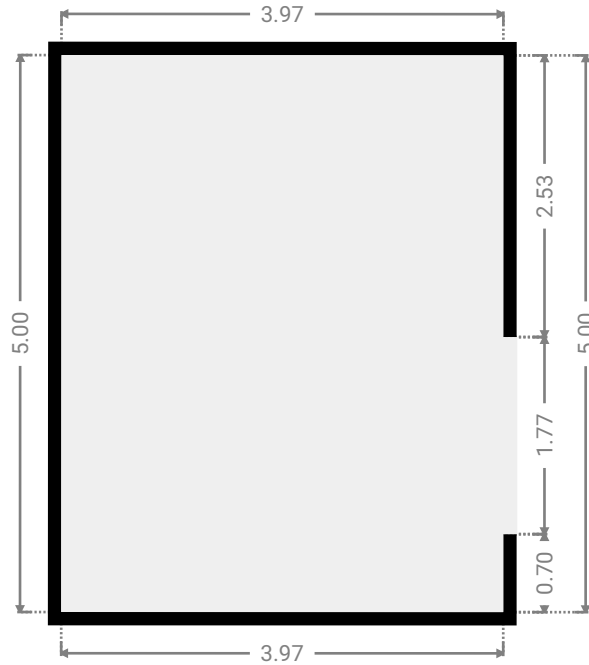
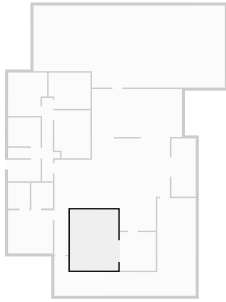

▼ **Other**  
Ground Floor

WIDTH: 7.40 m • LENGTH: 3.95 m  
AREA: 29.23 m<sup>2</sup> • PERIMETER: 22.70 m

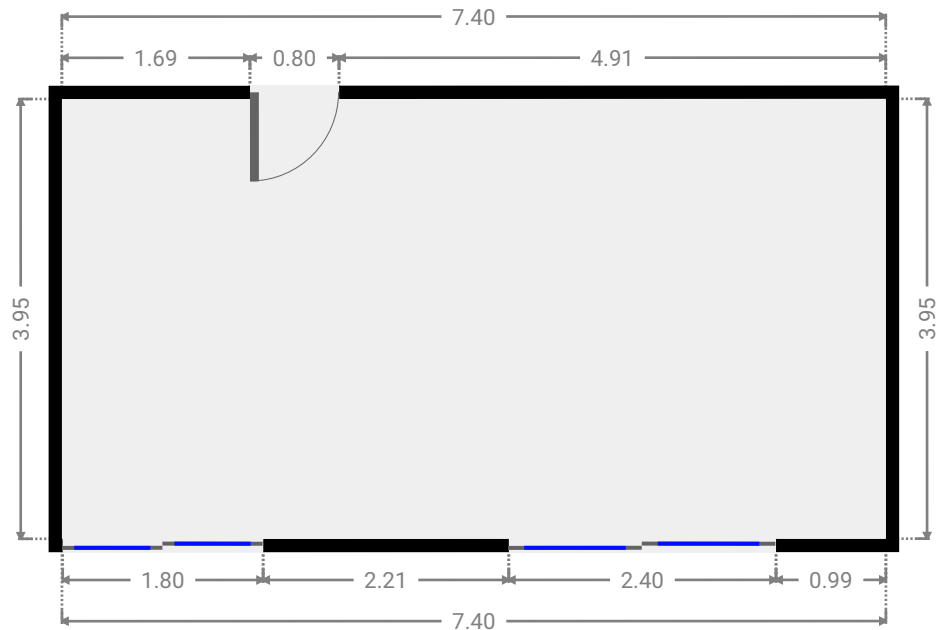
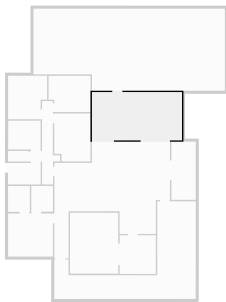



▼ **Other**  
Ground Floor

WIDTH: 11.63 m • LENGTH: 8.02 m  
AREA: 43.38 m<sup>2</sup> • PERIMETER: 41.91 m

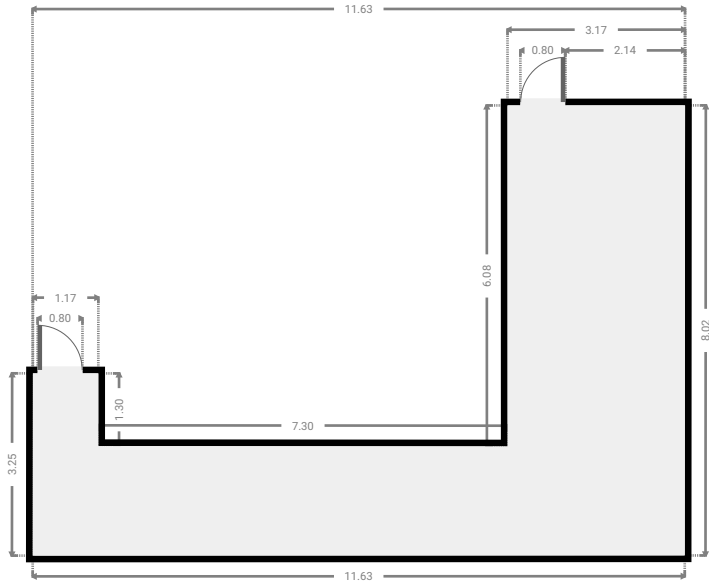
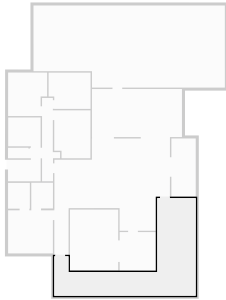

▼ **Other**  
Ground Floor

WIDTH: 15.73 m • LENGTH: 6.75 m  
AREA: 99.65 m<sup>2</sup> • PERIMETER: 44.95 m

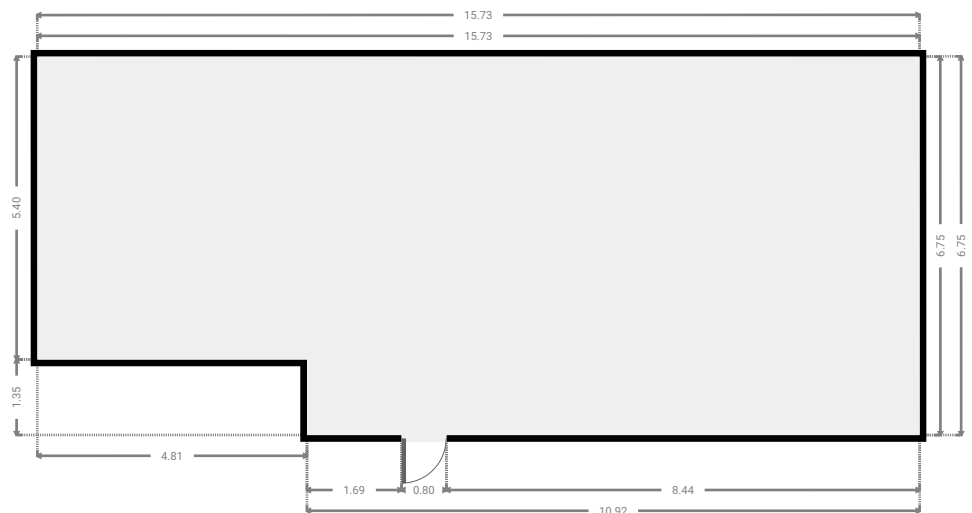
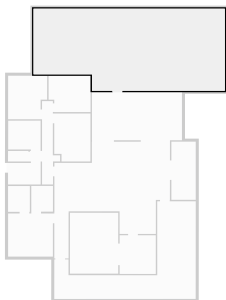

▼ **Primary Bedroom**  
Ground Floor

WIDTH: 3.68 m • LENGTH: 3.54 m  
AREA: 13.03 m<sup>2</sup> • PERIMETER: 14.44 m

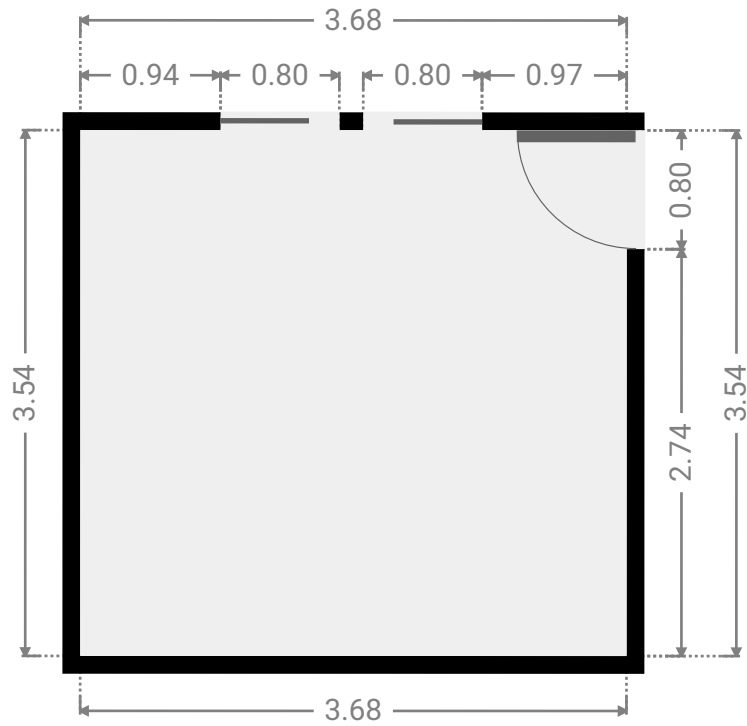
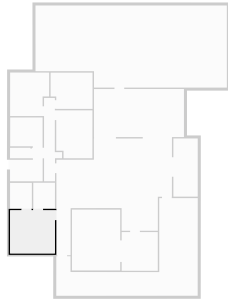

▼ **Closet**  
Ground Floor

WIDTH: 1.78 m • LENGTH: 2.12 m  
AREA: 3.76 m<sup>2</sup> • PERIMETER: 7.79 m

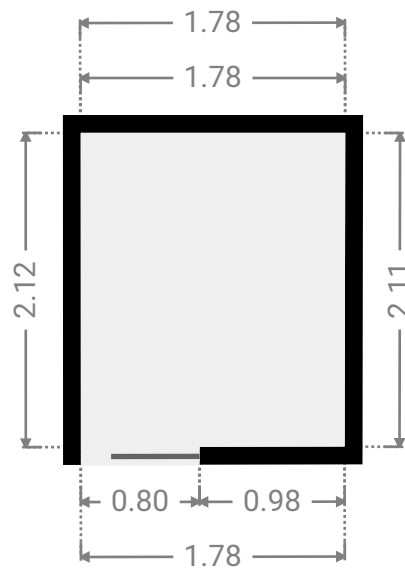
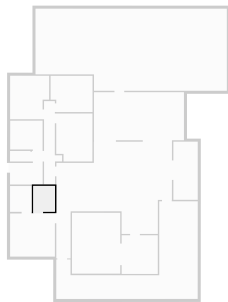

▼ **Study**  
Ground Floor

WIDTH: 2.97 m • LENGTH: 3.18 m  
AREA: 9.44 m<sup>2</sup> • PERIMETER: 12.30 m

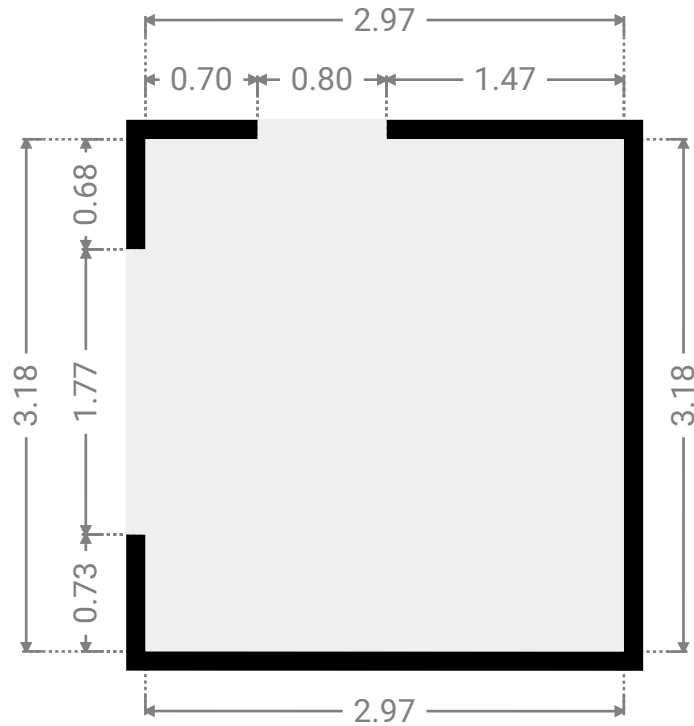
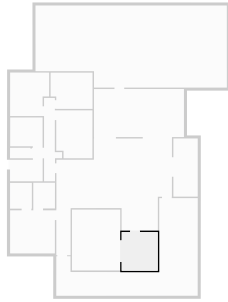

▼ **Toilet**  
Ground Floor

WIDTH: 1.68 m • LENGTH: 0.87 m  
AREA: 1.45 m<sup>2</sup> • PERIMETER: 5.09 m

