

# 493 Eichelberger Street

**SUBMITTED BY**

Ray White Rockhampton Casey  
stockers@cqoz.com

---

**CREATED ON**

2022-11-28

---

**Floors**

1

---

▼ Ground Floor



FLOORS: 1

▼ Bathroom  
Ground Floor

WIDTH: 3.09 m • LENGTH: 2.06 m  
AREA: 6.37 m<sup>2</sup> • PERIMETER: 10.30 m

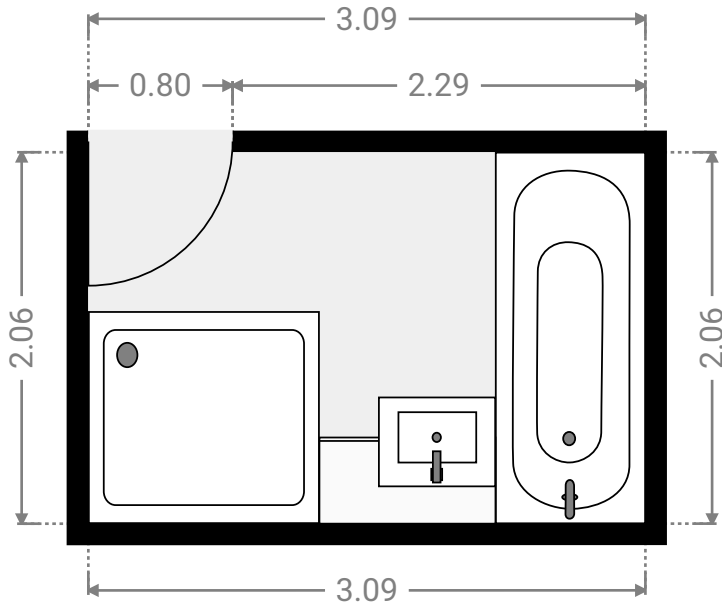
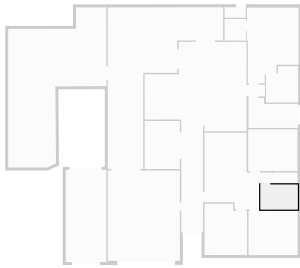

▼ Bathroom  
Ground Floor

WIDTH: 2.69 m • LENGTH: 3.03 m  
AREA: 7.40 m<sup>2</sup> • PERIMETER: 11.40 m

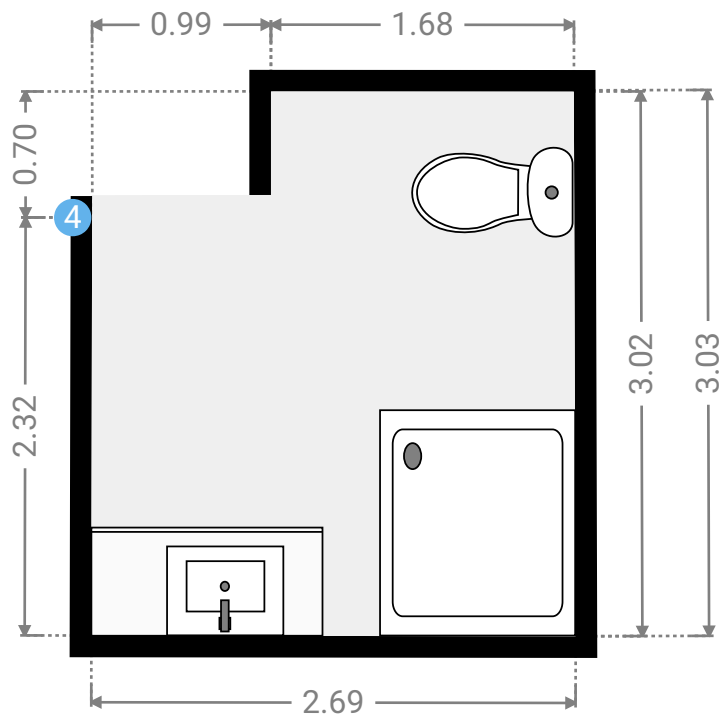
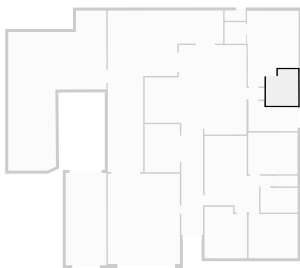

▼ Bathroom/Ground Floor

---

4 OPENING

Height  
0.00 m



▼ **Bedroom**  
Ground Floor

WIDTH: 3.54 m • LENGTH: 4.28 m  
AREA: 14.45 m<sup>2</sup> • PERIMETER: 15.64 m

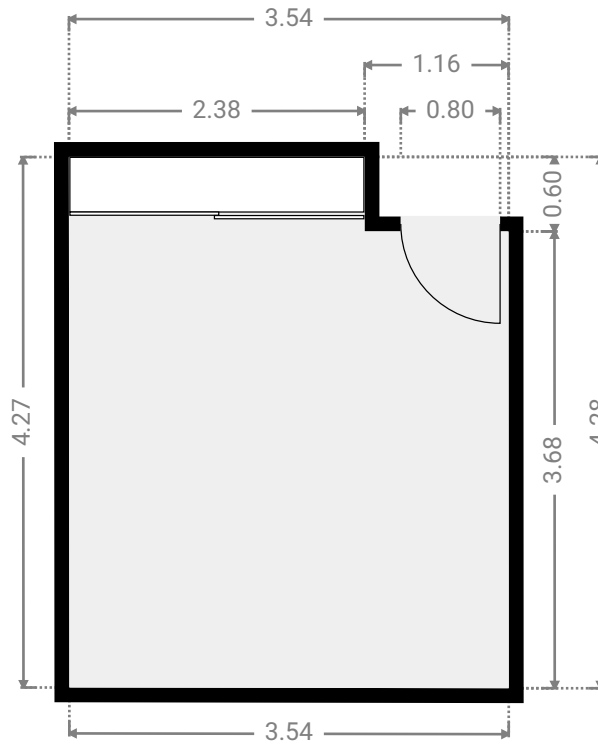

▼ **Bedroom**  
Ground Floor

WIDTH: 4.09 m • LENGTH: 3.68 m  
AREA: 15.05 m<sup>2</sup> • PERIMETER: 15.54 m

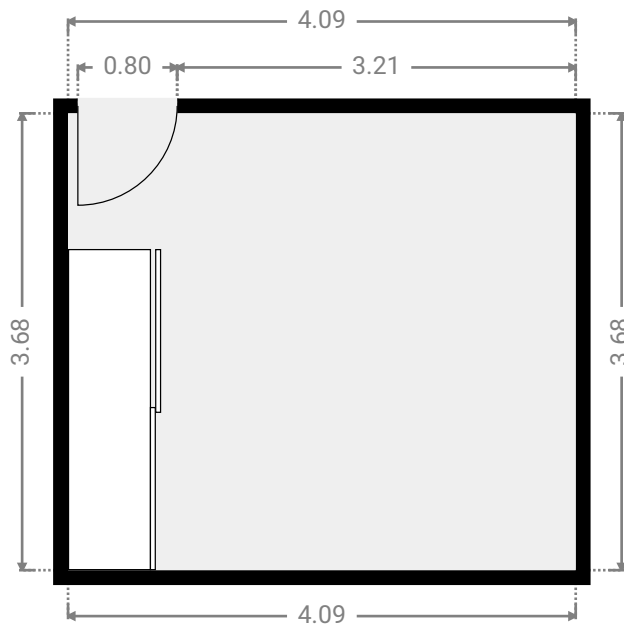

FLOORS: 1

▼ **Bedroom**  
Ground Floor

WIDTH: 4.10 m • LENGTH: 3.47 m  
AREA: 14.23 m<sup>2</sup> • PERIMETER: 15.14 m

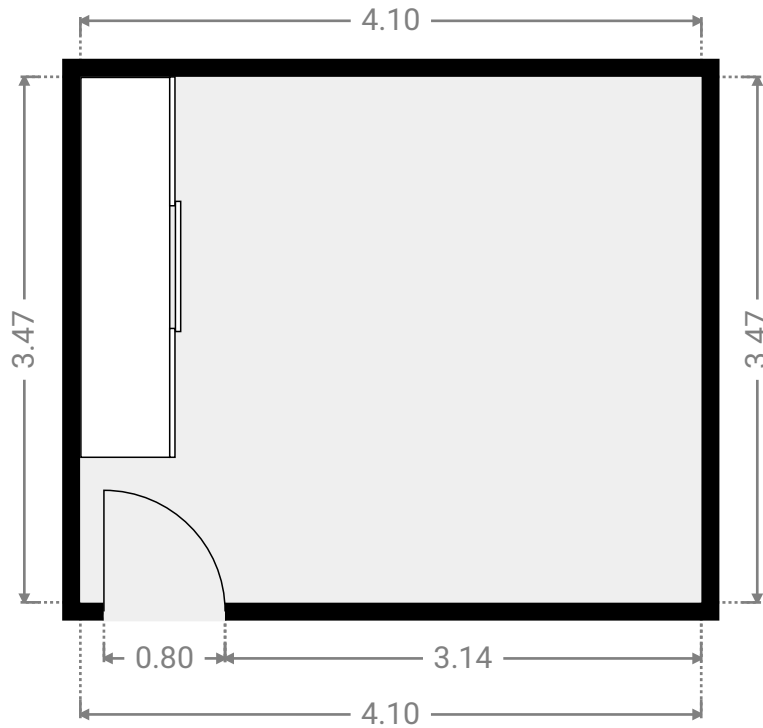
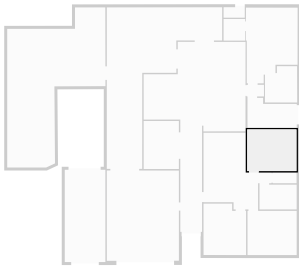

▼ **Closet**  
Ground Floor

WIDTH: 1.80 m • LENGTH: 1.80 m  
AREA: 3.24 m<sup>2</sup> • PERIMETER: 7.20 m

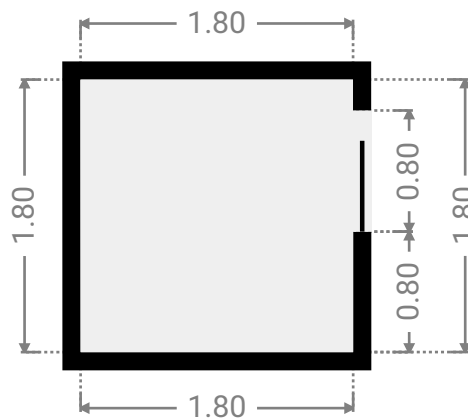

FLOORS: 1

▼ **Garage**  
Ground Floor

WIDTH: 6.01 m • LENGTH: 7.52 m  
AREA: 45.06 m<sup>2</sup> • PERIMETER: 27.02 m

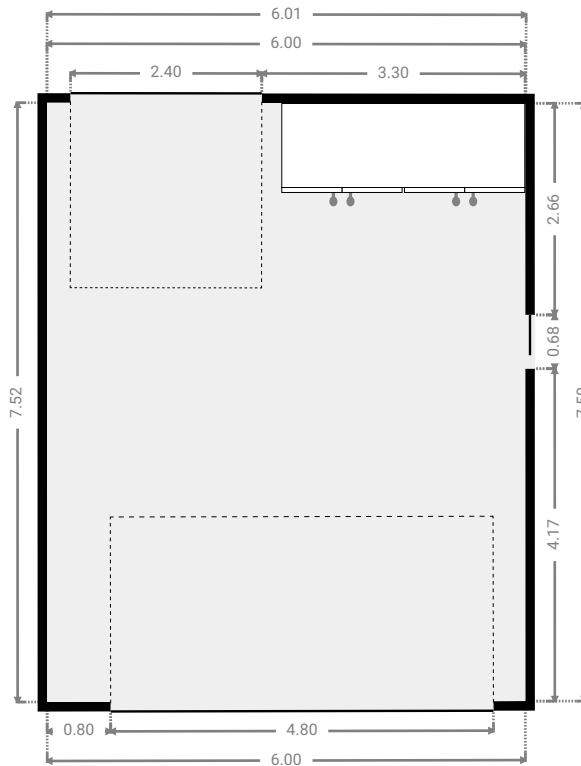

▼ **Garage**  
Ground Floor

WIDTH: 3.38 m • LENGTH: 7.68 m  
AREA: 25.96 m<sup>2</sup> • PERIMETER: 22.12 m

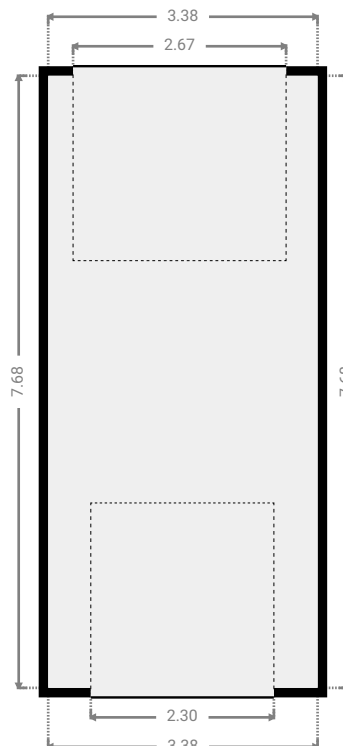

FLOORS: 1

▼ **Hall**  
Ground Floor

WIDTH: 1.81 m • LENGTH: 8.84 m  
AREA: 16.00 m<sup>2</sup> • PERIMETER: 21.30 m

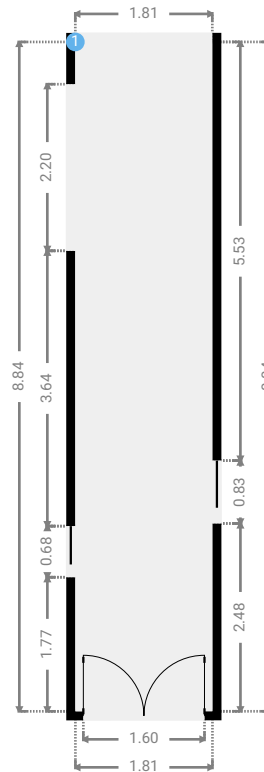
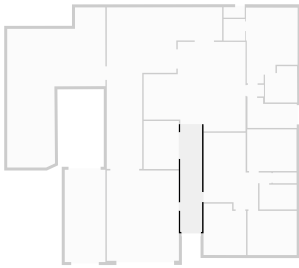

▼ **Hall/Ground Floor**

**1 OPENING**

Height  
0.00 m





FLOORS: 1

▼ **Hall**  
Ground Floor

WIDTH: 1.45 m • LENGTH: 0.97 m  
AREA: 1.41 m<sup>2</sup> • PERIMETER: 4.84 m

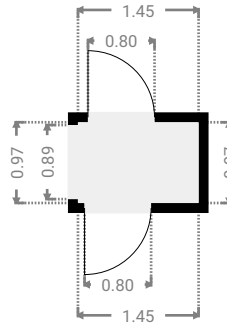
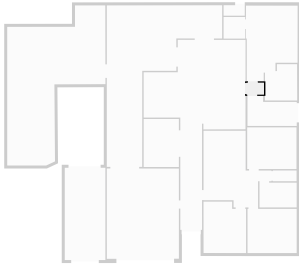

▼ **Kitchen**  
Ground Floor

WIDTH: 8.50 m • LENGTH: 7.46 m  
AREA: 51.34 m<sup>2</sup> • PERIMETER: 31.85 m

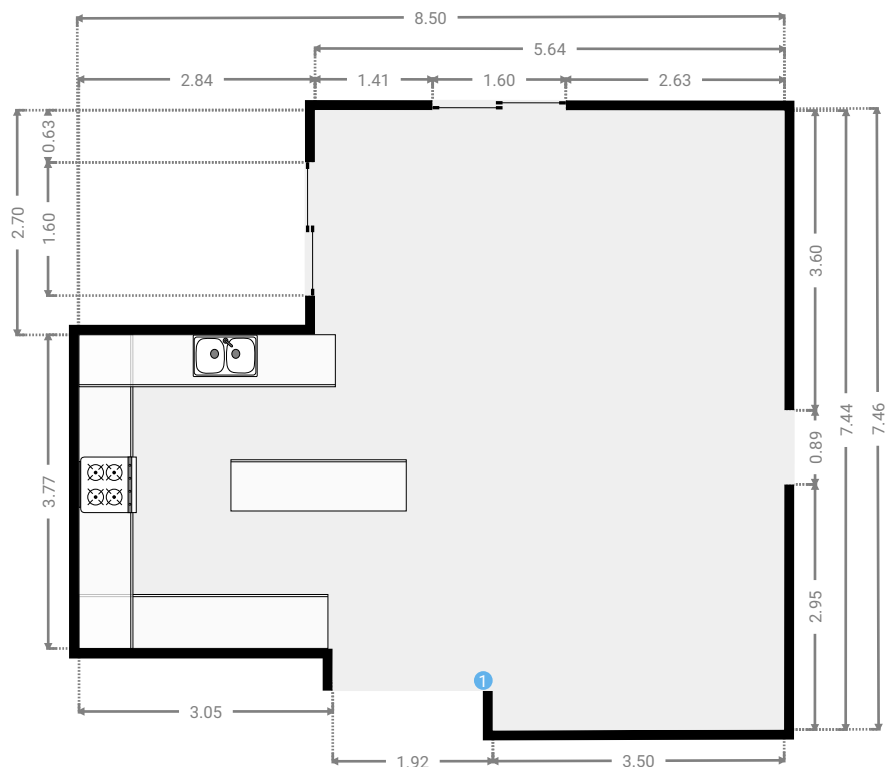
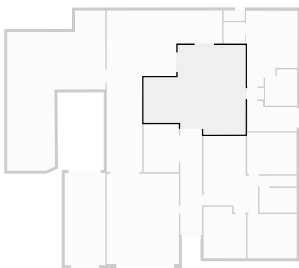

FLOORS: 1

▼ **Laundry Room**  
Ground Floor

WIDTH: 4.10 m • LENGTH: 2.50 m  
AREA: 8.85 m<sup>2</sup> • PERIMETER: 13.20 m

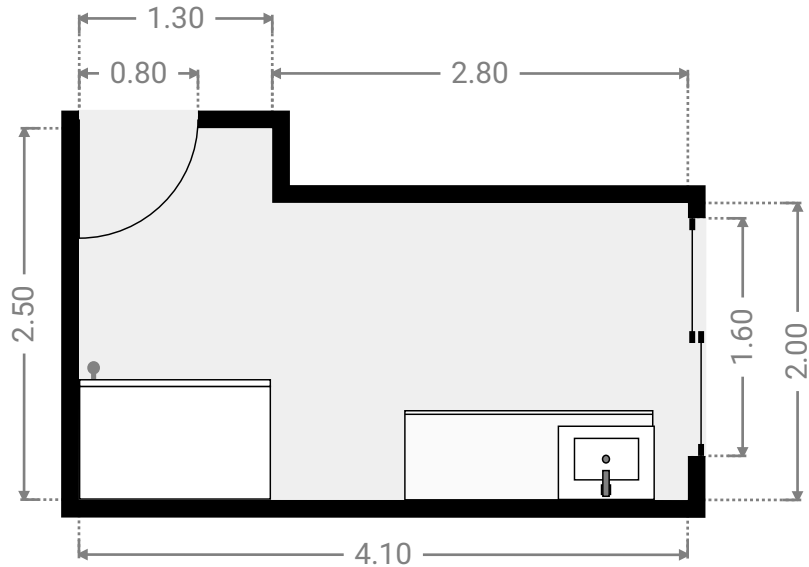

▼ **Living Room**  
Ground Floor

WIDTH: 2.93 m • LENGTH: 4.00 m  
AREA: 11.72 m<sup>2</sup> • PERIMETER: 13.86 m

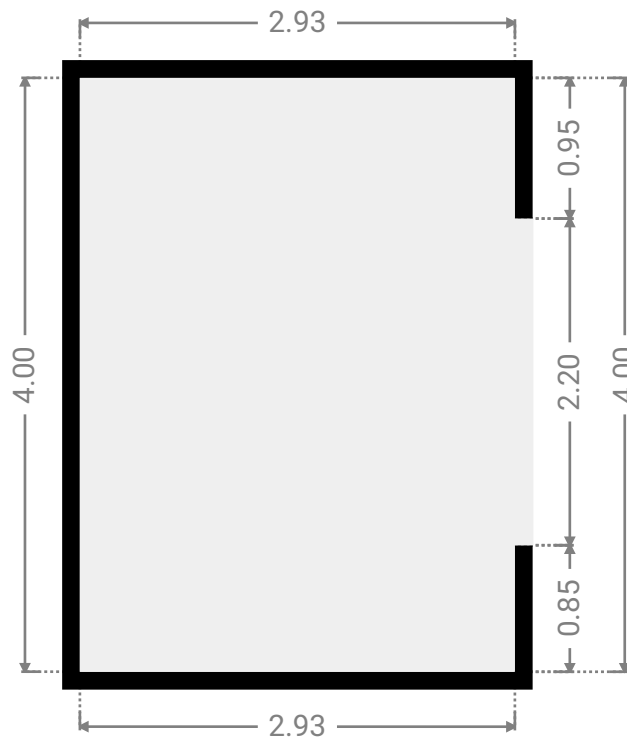
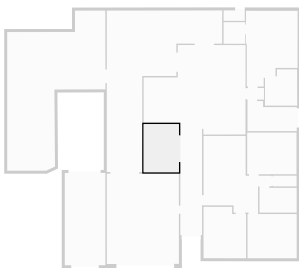

FLOORS: 1

▼ **Living Room**  
Ground Floor

WIDTH: 5.65 m • LENGTH: 6.38 m  
AREA: 25.02 m<sup>2</sup> • PERIMETER: 24.06 m

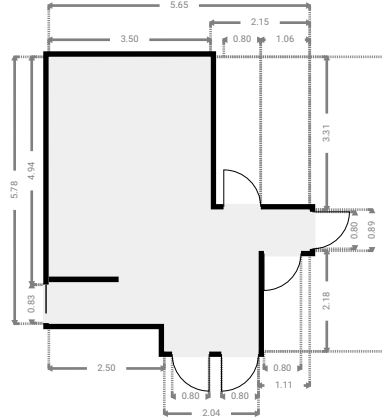

▼ **Other**  
Ground Floor

WIDTH: 9.60 m • LENGTH: 13.46 m  
AREA: 65.62 m<sup>2</sup> • PERIMETER: 46.09 m

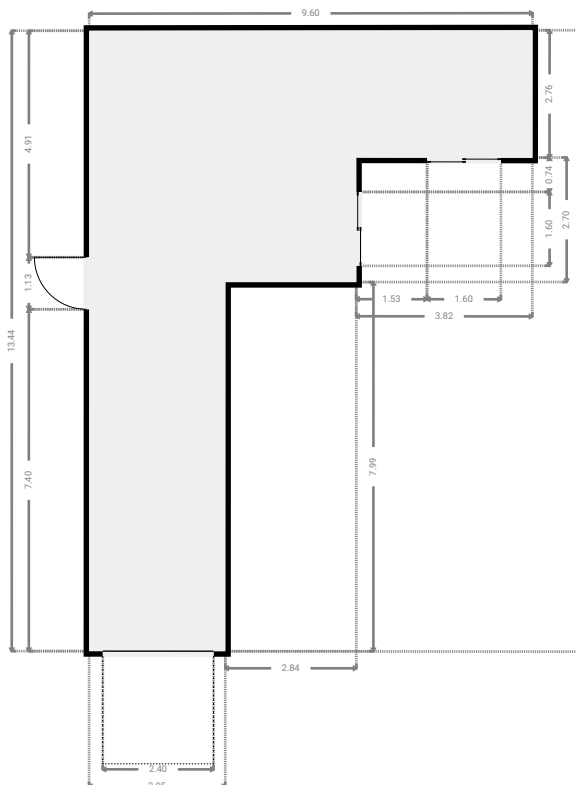
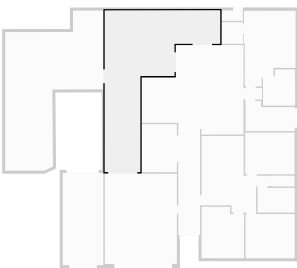

FLOORS: 1

▼ **Other**  
Ground Floor

WIDTH: 8.21 m • LENGTH: 13.31 m  
AREA: 70.12 m<sup>2</sup> • PERIMETER: 42.75 m

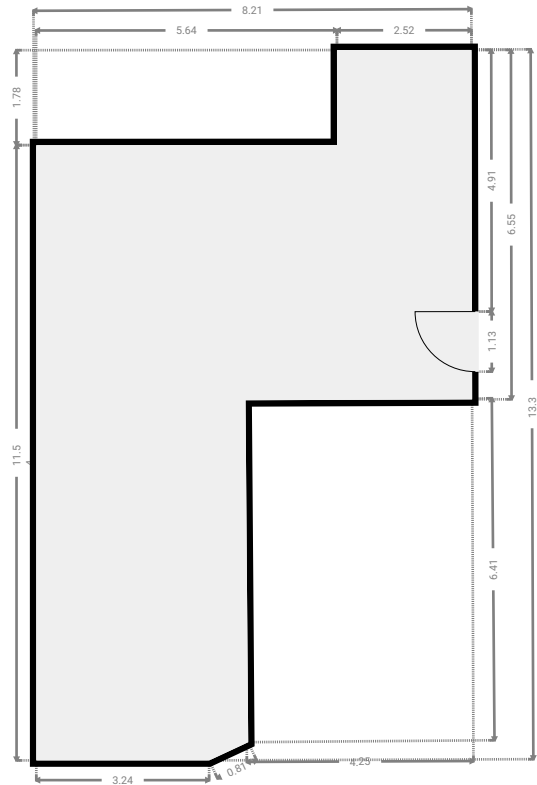
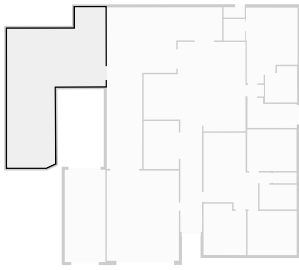

▼ **Primary Bedroom**  
Ground Floor

WIDTH: 4.30 m • LENGTH: 6.30 m  
AREA: 23.14 m<sup>2</sup> • PERIMETER: 21.20 m

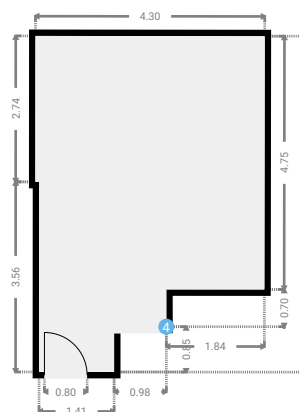
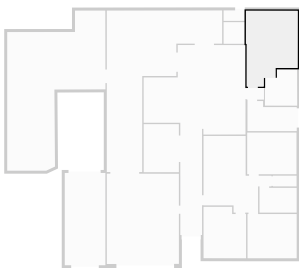

FLOORS: 1

▼ **Toilet**  
Ground Floor

WIDTH: 1.97 m • LENGTH: 0.89 m  
AREA: 1.76 m<sup>2</sup> • PERIMETER: 5.73 m

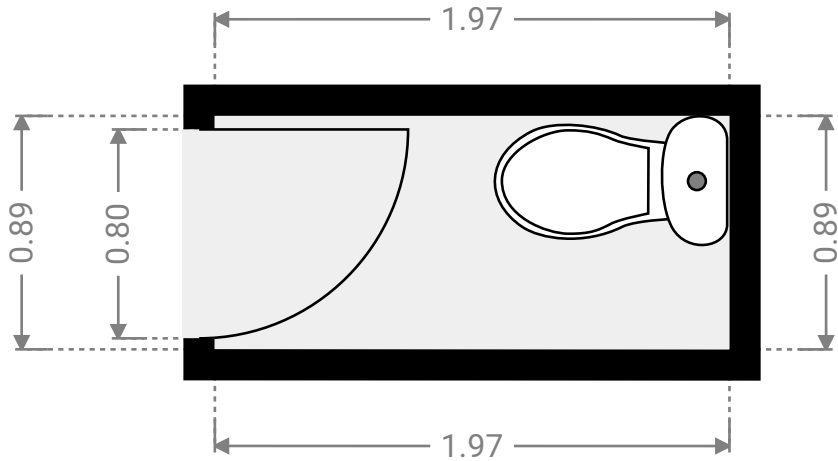

▼ **Toilet**  
Ground Floor

WIDTH: 1.76 m • LENGTH: 0.87 m  
AREA: 1.53 m<sup>2</sup> • PERIMETER: 5.26 m

