

# 48 Macgregor Street

## Ground Floor

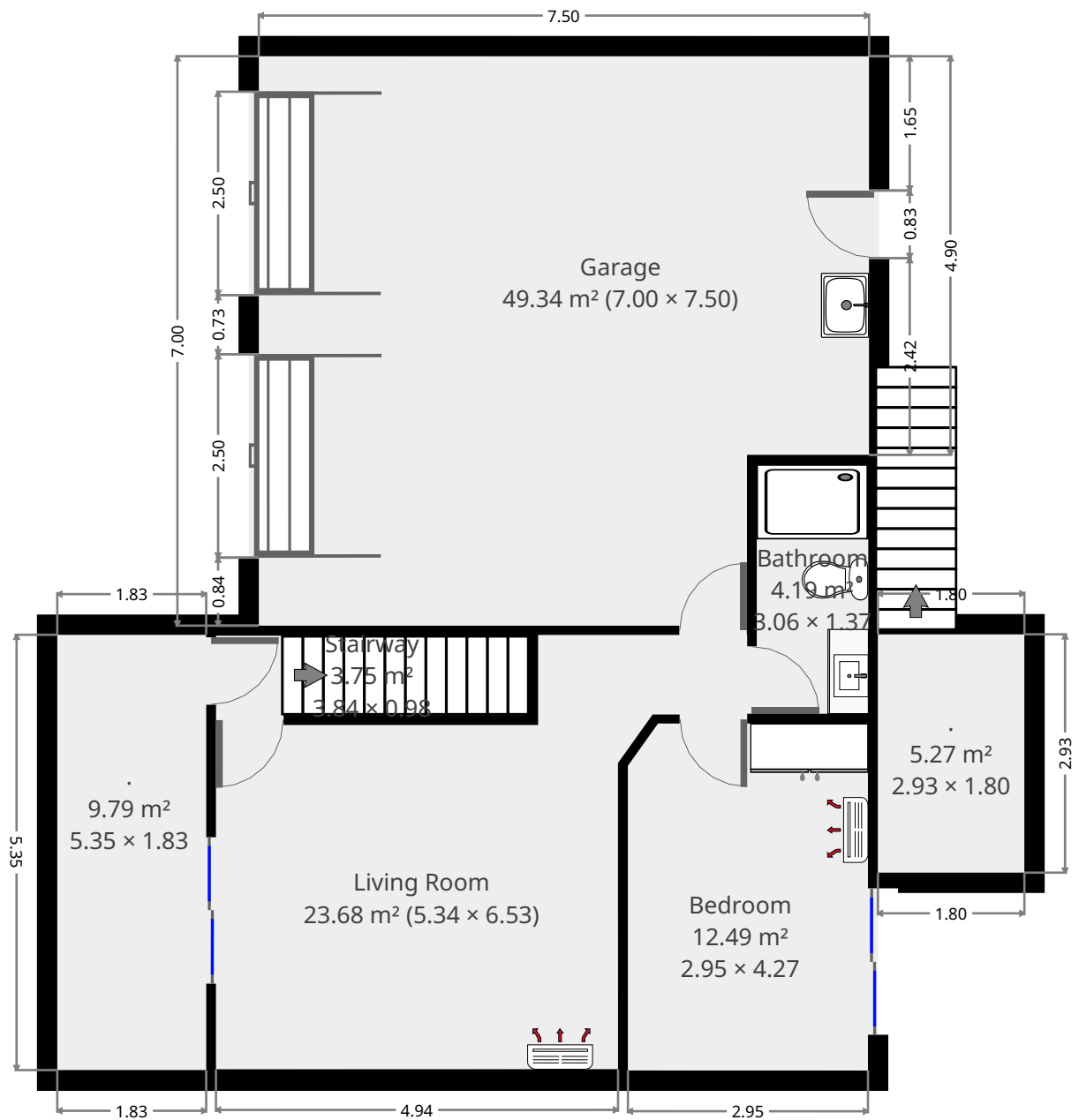

THIS FLOORPLAN IS PROVIDED WITHOUT WARRANTY OF ANY KIND. SENSOPIA DISCLAIMS ANY WARRANTY INCLUDING, WITHOUT LIMITATION, SATISFACTORY QUALITY OR ACCURACY OF DIMENSIONS.



# 48 Macgregor Street

## Living Room

Width: 5.34 m  
 Length: 6.53 m  
 Area: 23.68 m<sup>2</sup>  
 Perimeter: 23.45 m

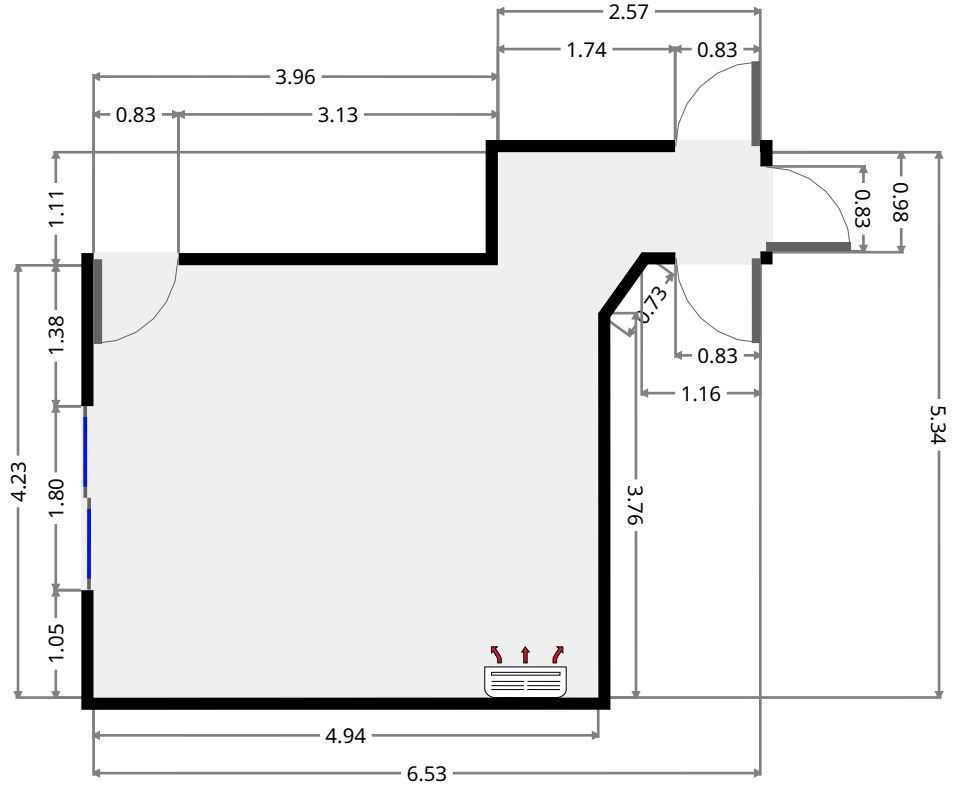
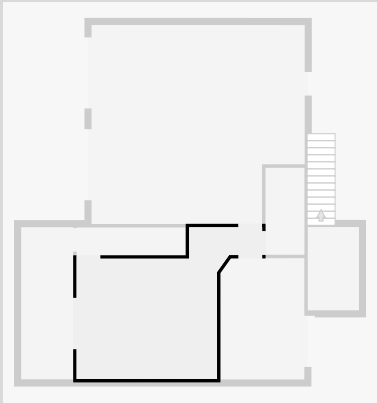

## Bedroom

Width: 2.95 m  
 Length: 4.27 m  
 Area: 12.49 m<sup>2</sup>  
 Perimeter: 14.18 m

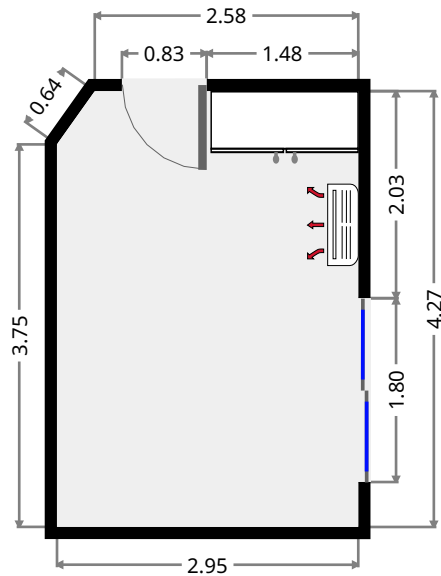
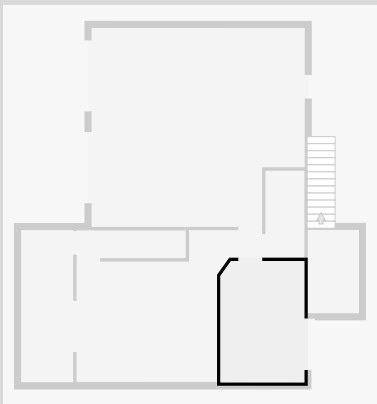

THIS FLOORPLAN IS PROVIDED WITHOUT WARRANTY OF ANY KIND. SENSOPIA DISCLAIMS ANY WARRANTY INCLUDING, WITHOUT LIMITATION, SATISFACTORY QUALITY OR ACCURACY OF DIMENSIONS.



# 48 Macgregor Street

## Bathroom

Width: 1.37 m  
 Length: 3.06 m  
 Area: 4.19 m<sup>2</sup>  
 Perimeter: 8.86 m

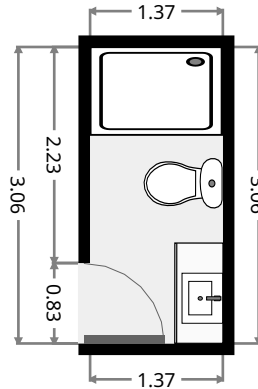
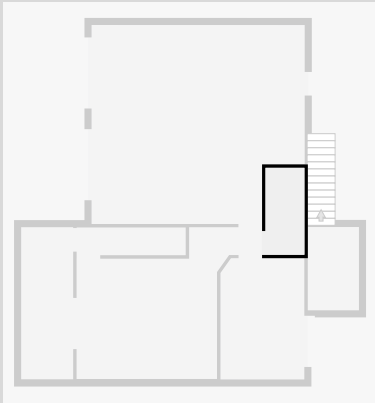

## Garage

Width: 7.00 m  
 Length: 7.50 m  
 Area: 49.34 m<sup>2</sup>  
 Perimeter: 29.00 m

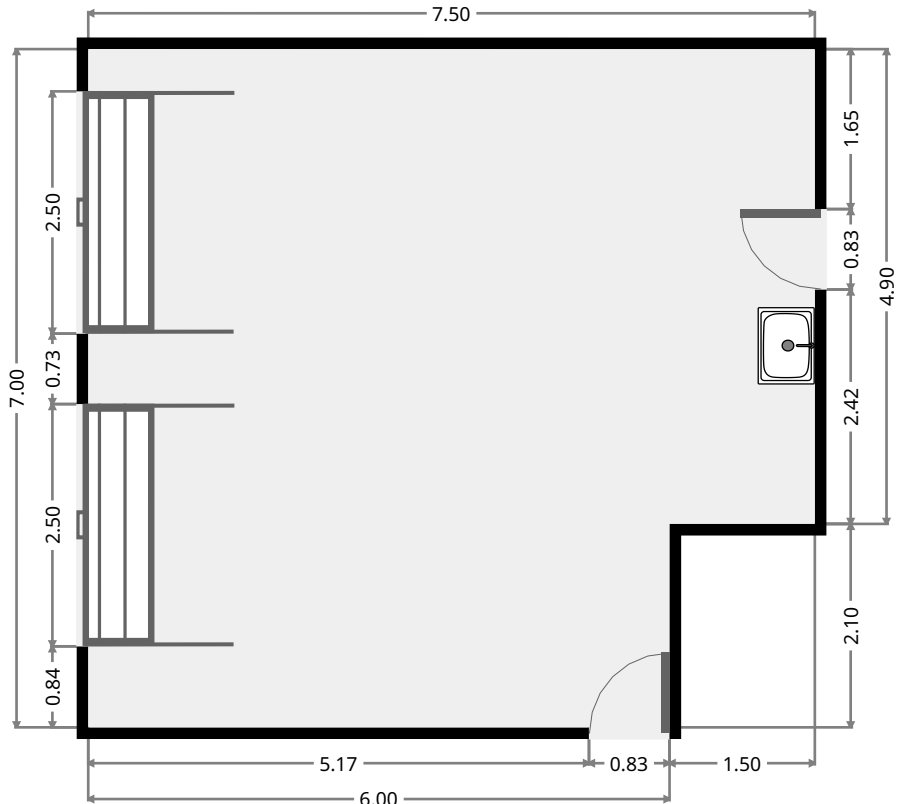
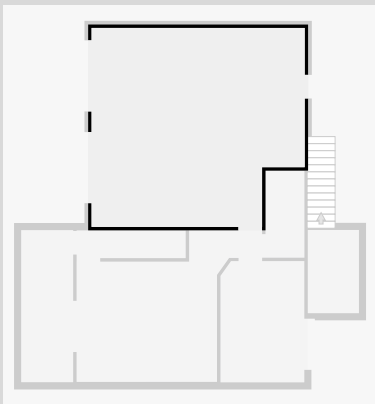

THIS FLOORPLAN IS PROVIDED WITHOUT WARRANTY OF ANY KIND. SENSOPIA DISCLAIMS ANY WARRANTY INCLUDING, WITHOUT LIMITATION, SATISFACTORY QUALITY OR ACCURACY OF DIMENSIONS.

# 48 Macgregor Street

## Stairway

Width: 0.98 m  
 Length: 3.84 m  
 Area: 3.75 m<sup>2</sup>  
 Perimeter: 9.63 m

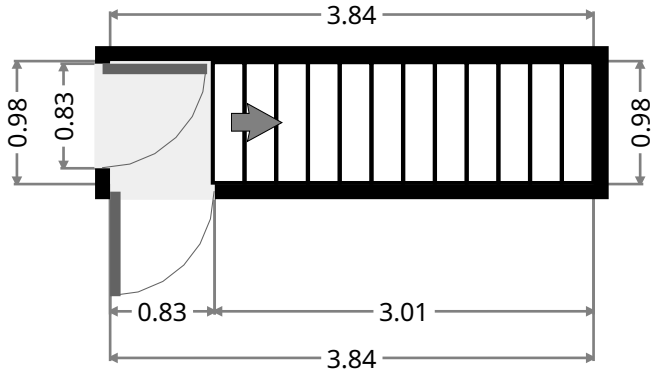
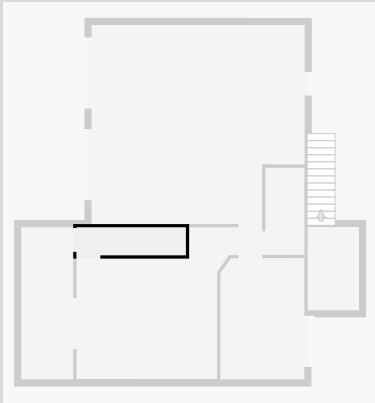

Width: 1.83 m  
 Length: 5.35 m  
 Area: 9.79 m<sup>2</sup>  
 Perimeter: 14.36 m

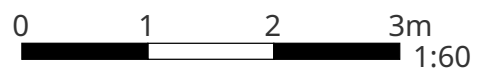
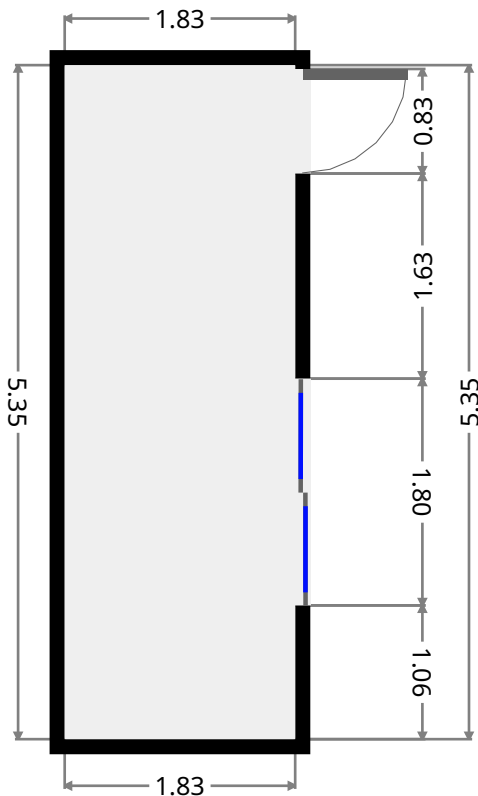
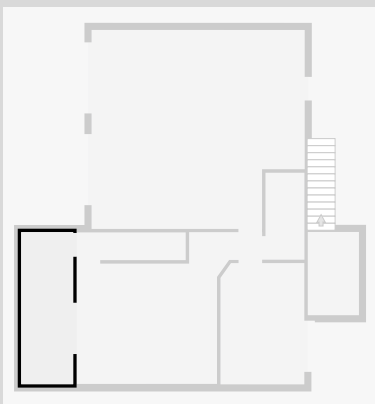

THIS FLOORPLAN IS PROVIDED WITHOUT WARRANTY OF ANY KIND. SENSOPIA DISCLAIMS ANY WARRANTY INCLUDING, WITHOUT LIMITATION, SATISFACTORY QUALITY OR ACCURACY OF DIMENSIONS.

# 48 Macgregor Street

•  
Width: 1.80 m  
Length: 2.93 m  
Area: 5.27 m<sup>2</sup>  
Perimeter: 9.46 m

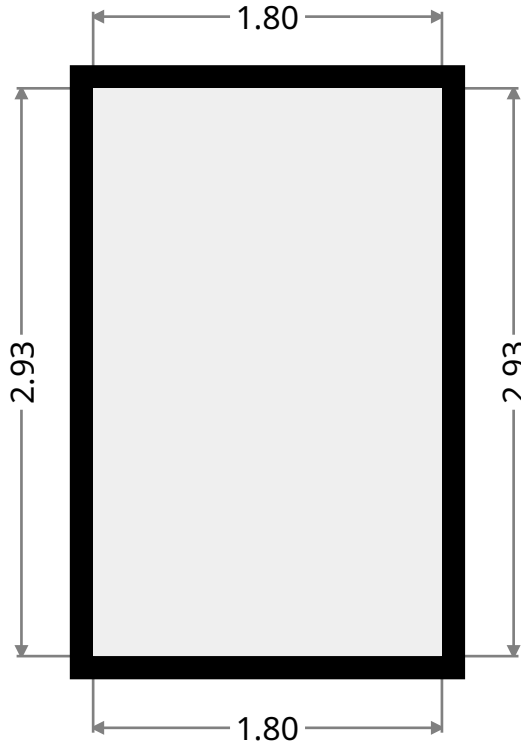
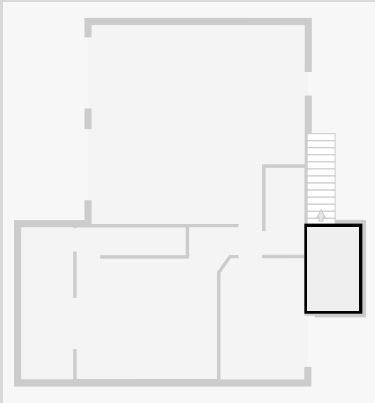

# 48 Macgregor Street

## 1st Floor

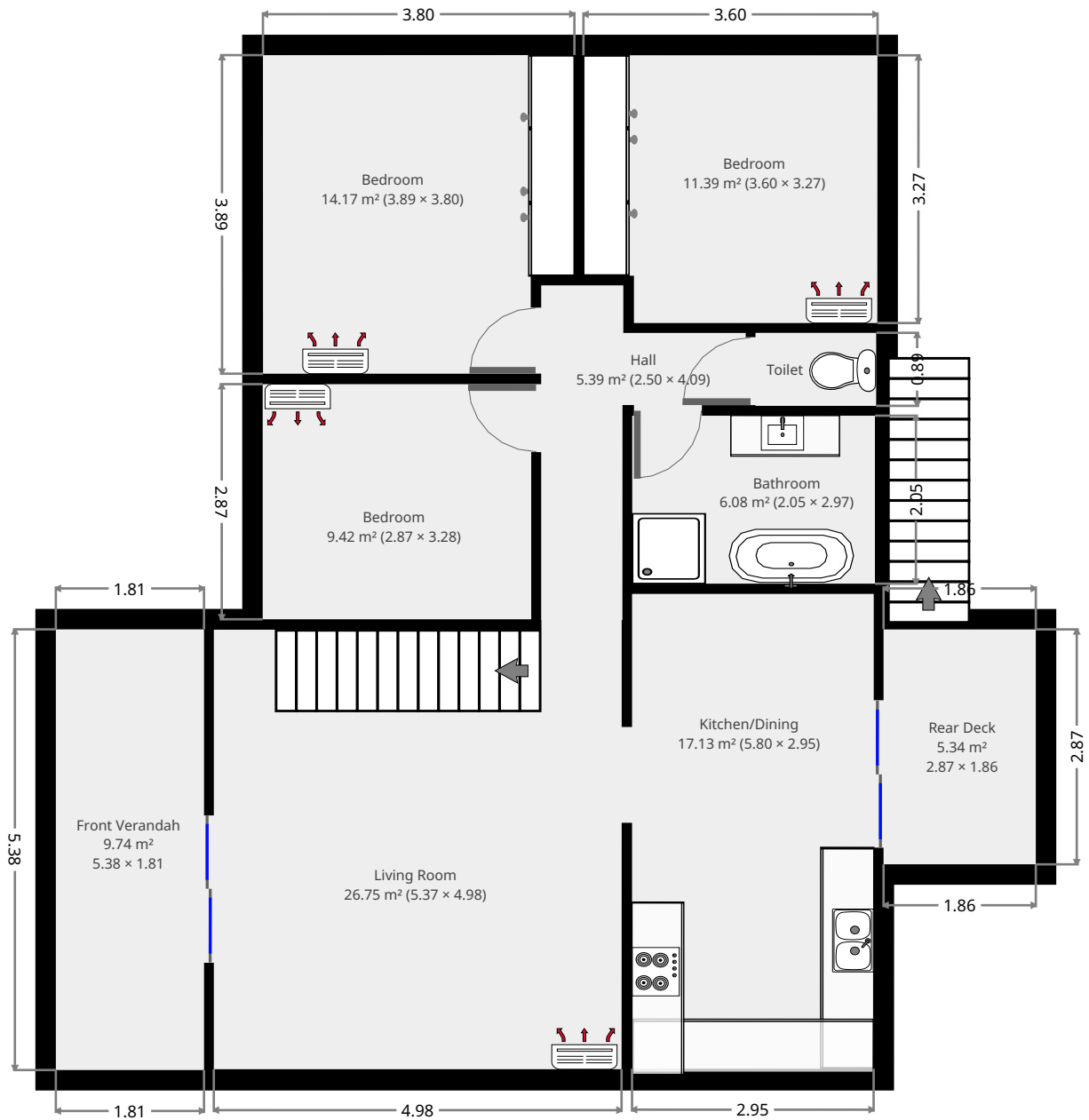

THIS FLOORPLAN IS PROVIDED WITHOUT WARRANTY OF ANY KIND. SENSOPIA DISCLAIMS ANY WARRANTY INCLUDING, WITHOUT LIMITATION, SATISFACTORY QUALITY OR ACCURACY OF DIMENSIONS.



# 48 Macgregor Street

## Living Room

Width: 4.98 m  
 Length: 5.37 m  
 Area: 26.75 m<sup>2</sup>  
 Perimeter: 20.70 m

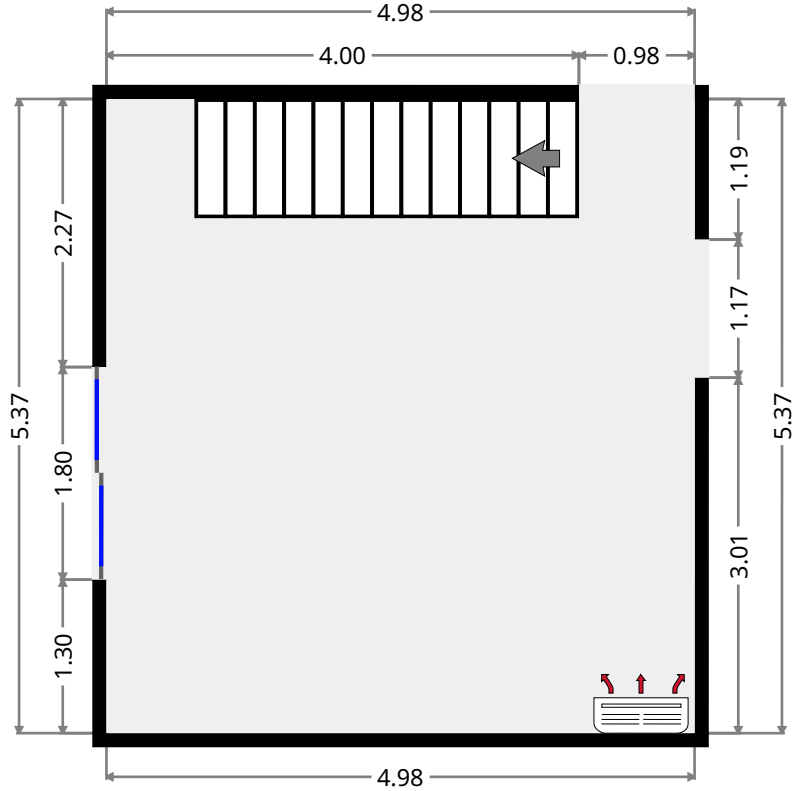
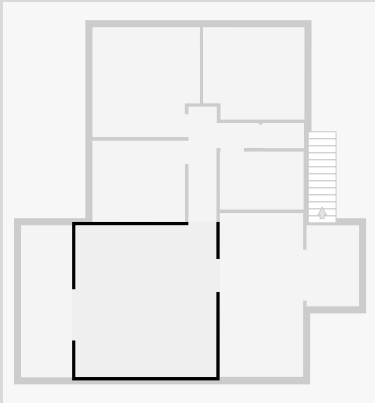

## Kitchen/Dining

Width: 2.95 m  
 Length: 5.80 m  
 Area: 17.13 m<sup>2</sup>  
 Perimeter: 17.51 m

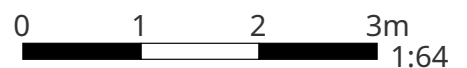
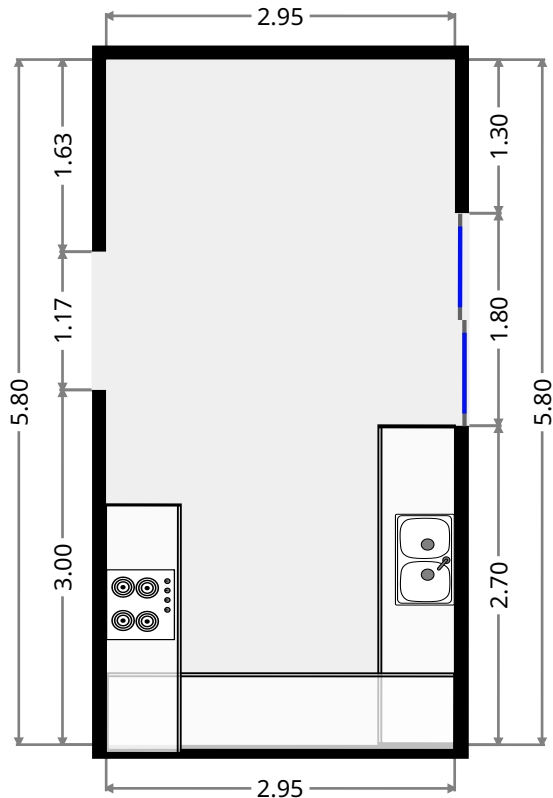
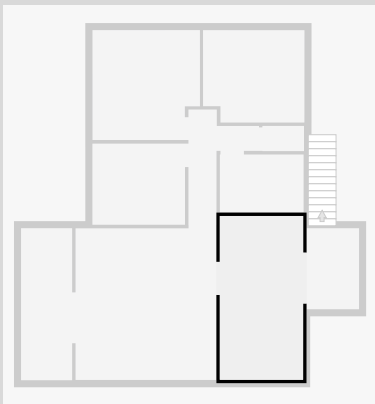

THIS FLOORPLAN IS PROVIDED WITHOUT WARRANTY OF ANY KIND. SENSOPIA DISCLAIMS ANY WARRANTY INCLUDING, WITHOUT LIMITATION, SATISFACTORY QUALITY OR ACCURACY OF DIMENSIONS.

# 48 Macgregor Street

## Hall

Width: 2.50 m  
 Length: 4.09 m  
 Area: 5.39 m<sup>2</sup>  
 Perimeter: 13.17 m

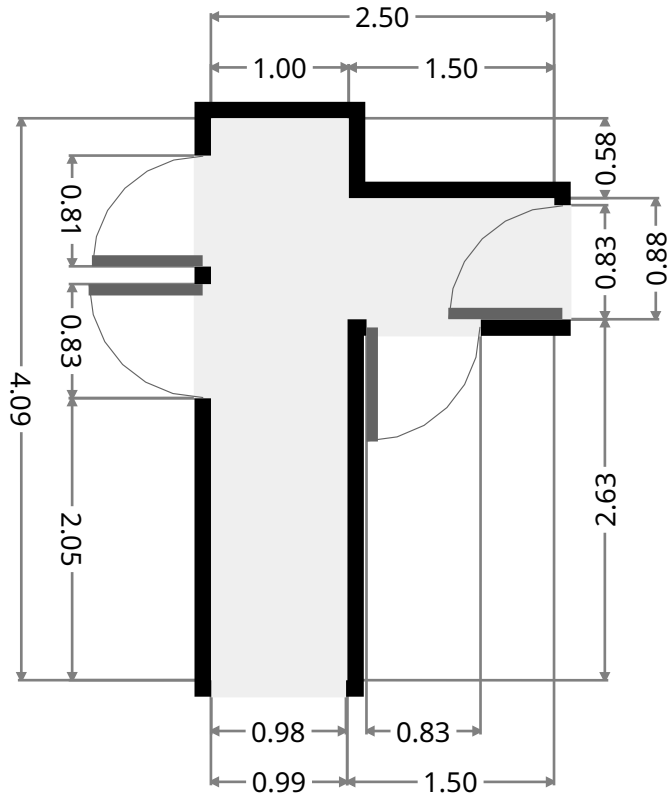
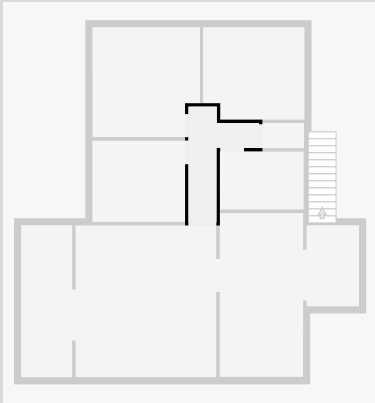

## Bedroom

Width: 2.87 m  
 Length: 3.28 m  
 Area: 9.42 m<sup>2</sup>  
 Perimeter: 12.30 m

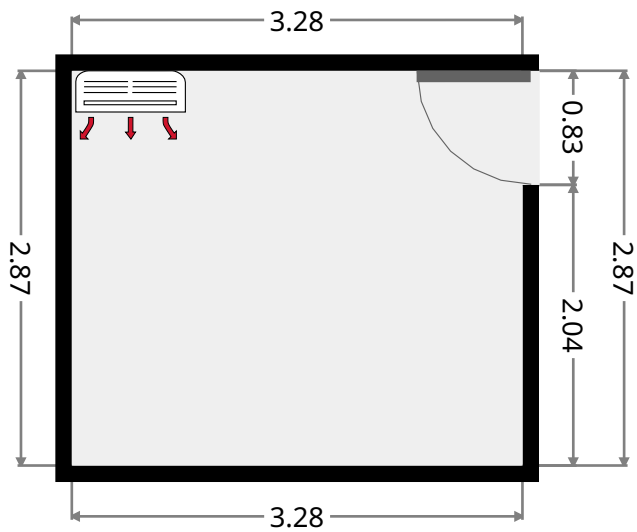
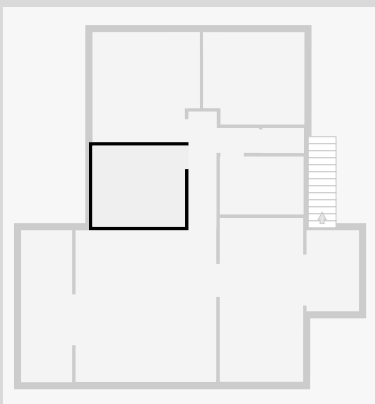



# 48 Macgregor Street

## Bedroom

Width: 3.80 m  
 Length: 3.89 m  
 Area: 14.17 m<sup>2</sup>  
 Perimeter: 15.39 m

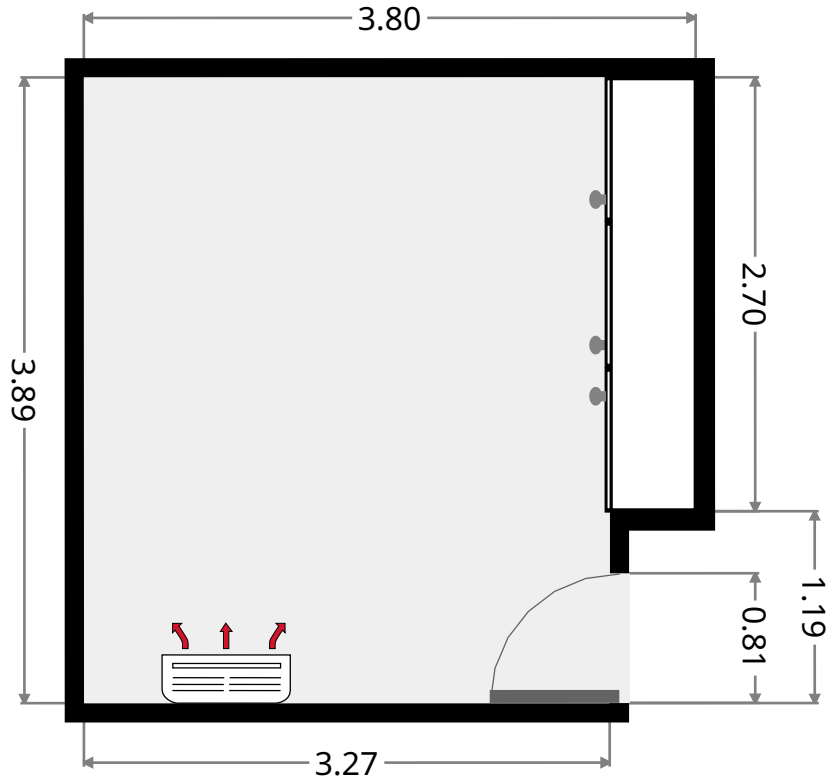
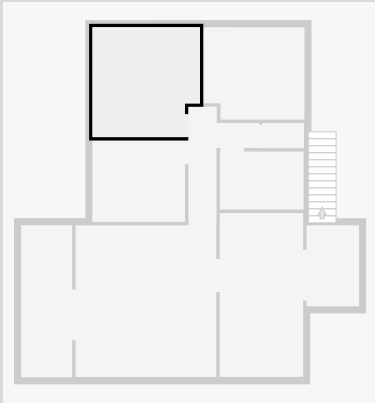

## Bedroom

Width: 3.27 m  
 Length: 3.60 m  
 Area: 11.39 m<sup>2</sup>  
 Perimeter: 13.72 m

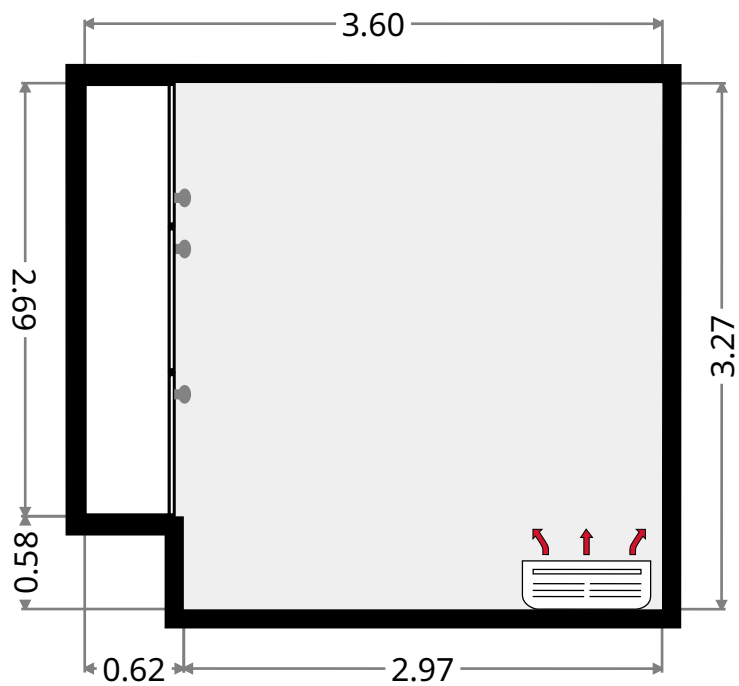
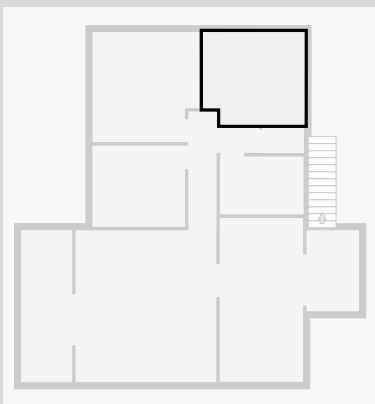

THIS FLOORPLAN IS PROVIDED WITHOUT WARRANTY OF ANY KIND. SENSOPIA DISCLAIMS ANY WARRANTY INCLUDING, WITHOUT LIMITATION, SATISFACTORY QUALITY OR ACCURACY OF DIMENSIONS.

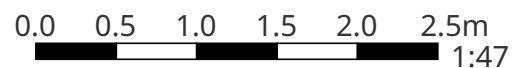

# 48 Macgregor Street

## Bathroom

Width: 2.05 m  
 Length: 2.97 m  
 Area: 6.08 m<sup>2</sup>  
 Perimeter: 10.03 m

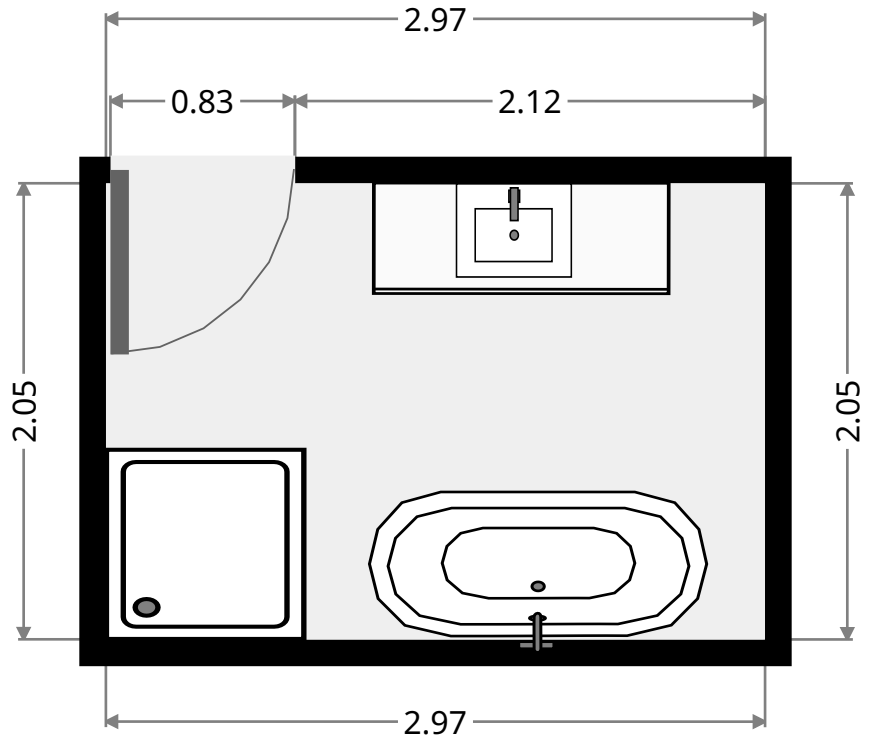
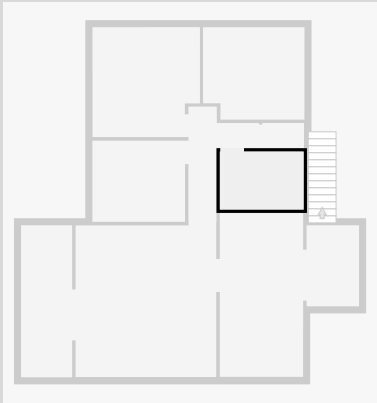

## Toilet

Width: 0.89 m  
 Length: 1.48 m  
 Area: 1.32 m<sup>2</sup>  
 Perimeter: 4.73 m

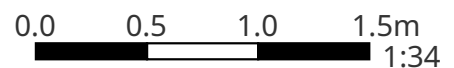
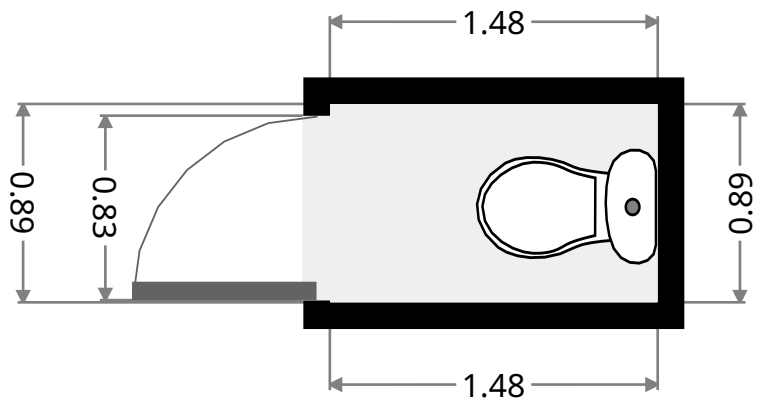
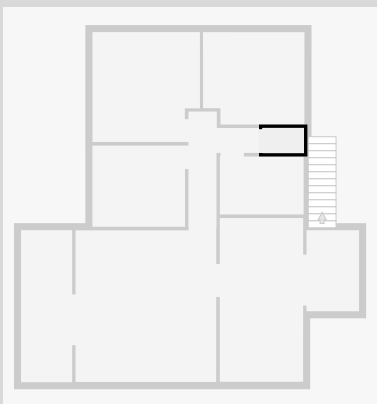

THIS FLOORPLAN IS PROVIDED WITHOUT WARRANTY OF ANY KIND. SENSOPIA DISCLAIMS ANY WARRANTY INCLUDING, WITHOUT LIMITATION, SATISFACTORY QUALITY OR ACCURACY OF DIMENSIONS.

# 48 Macgregor Street

## Front Verandah

Width: 1.81 m  
 Length: 5.38 m  
 Area: 9.74 m<sup>2</sup>  
 Perimeter: 14.39 m

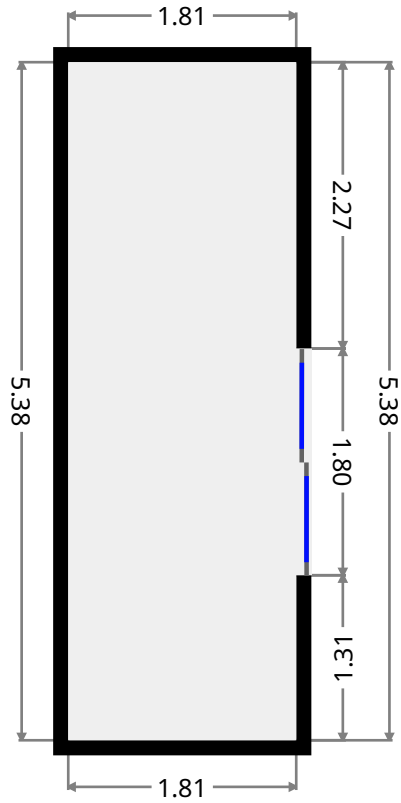
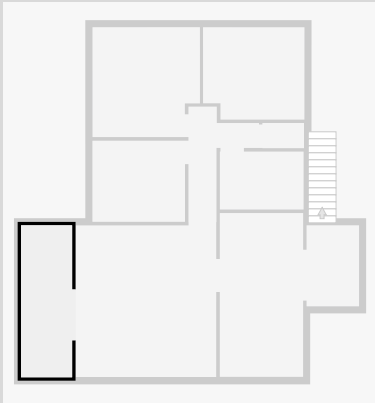

## Rear Deck

Width: 1.86 m  
 Length: 2.87 m  
 Area: 5.34 m<sup>2</sup>  
 Perimeter: 9.46 m

