

47 Western Street

Created on
2019-01-15

Floors
1

▼ Ground Floor

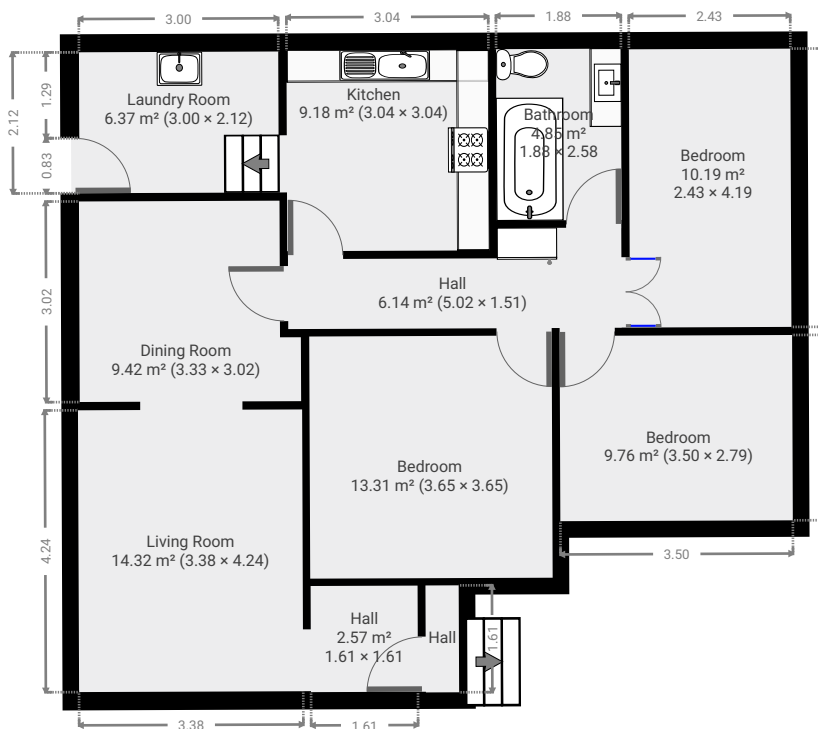
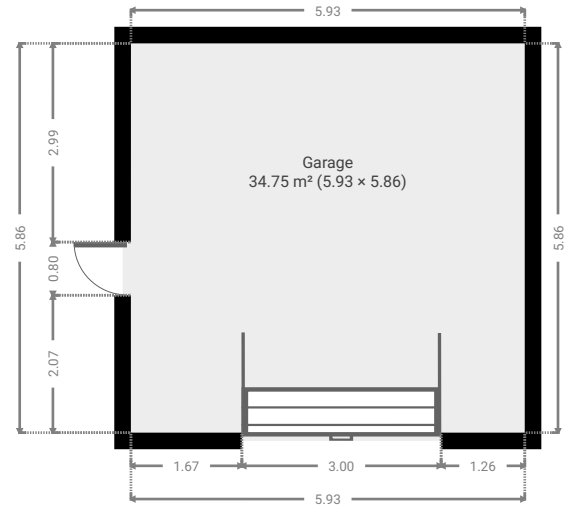
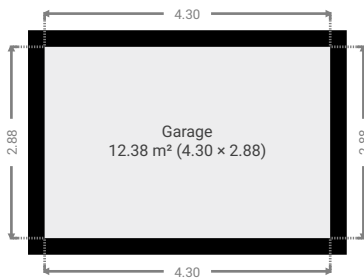

▼ **Hall**
Ground Floor

WIDTH: 1.61 m • LENGTH: 1.61 m
AREA: 2.57 m² • PERIMETER: 6.42 m

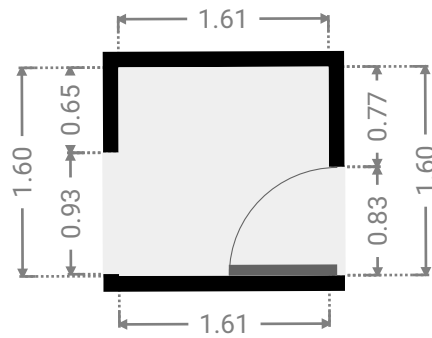
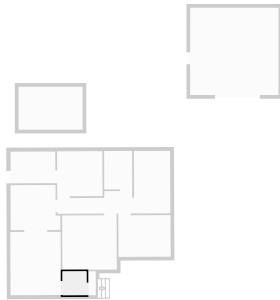

▼ **Living Room**
Ground Floor

WIDTH: 3.38 m • LENGTH: 4.24 m
AREA: 14.32 m² • PERIMETER: 15.24 m

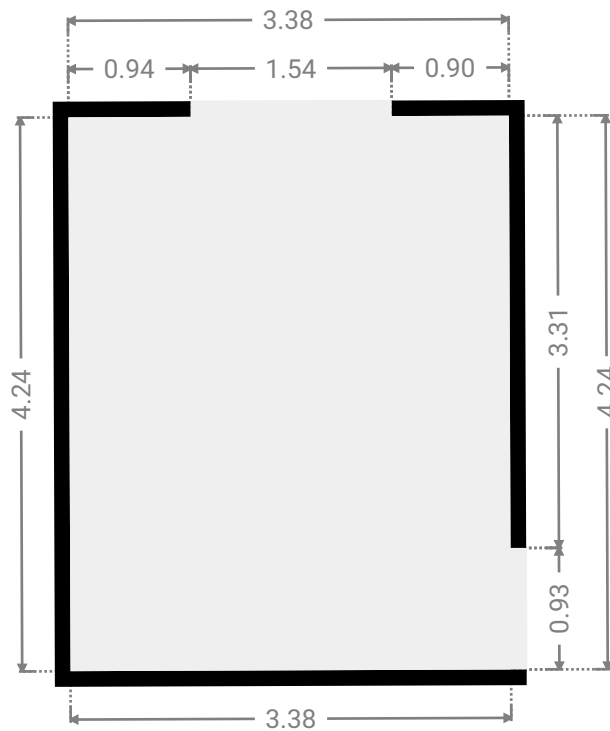
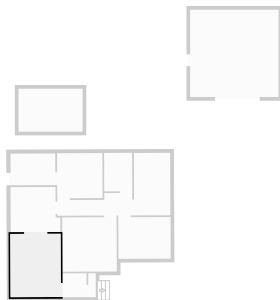

▼ Dining Room
Ground Floor

WIDTH: 3.33 m • LENGTH: 3.02 m
AREA: 9.42 m² • PERIMETER: 12.71 m

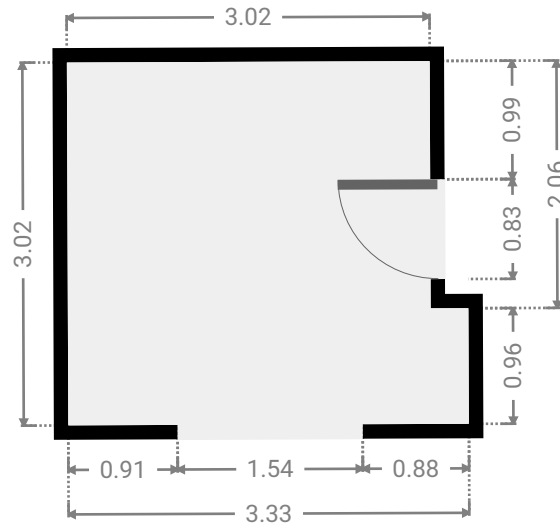
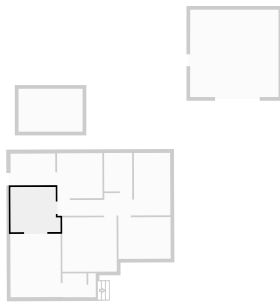

▼ Hall
Ground Floor

WIDTH: 5.02 m • LENGTH: 1.51 m
AREA: 6.14 m² • PERIMETER: 13.06 m

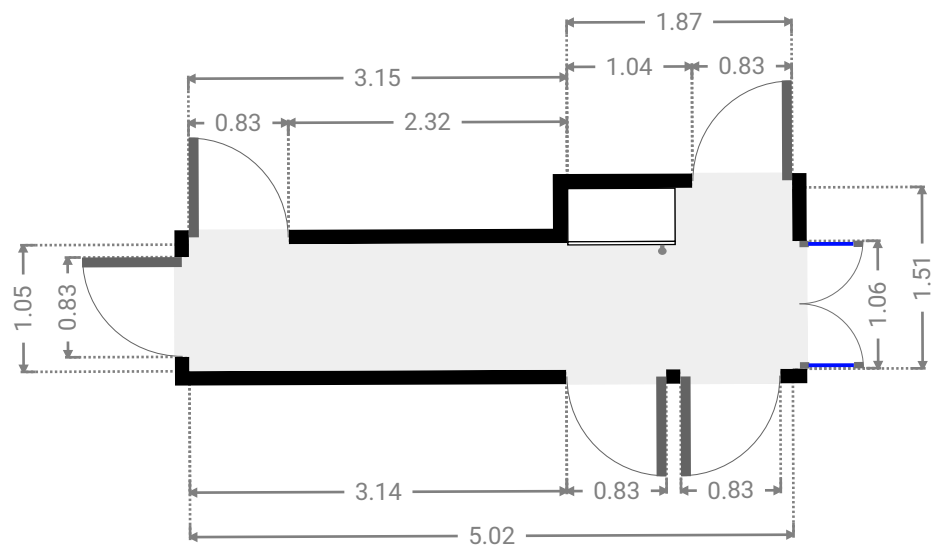

▼ **Bedroom**
Ground Floor

WIDTH: 3.65 m • LENGTH: 3.65 m
AREA: 13.31 m² • PERIMETER: 14.59 m

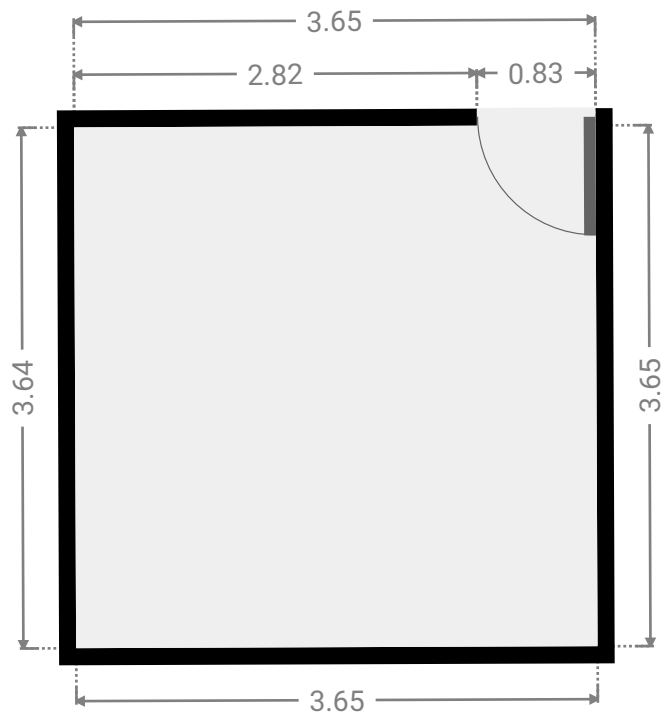
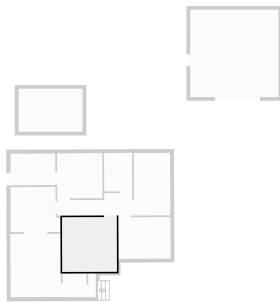

▼ **Bedroom**
Ground Floor

WIDTH: 3.50 m • LENGTH: 2.79 m
AREA: 9.76 m² • PERIMETER: 12.58 m

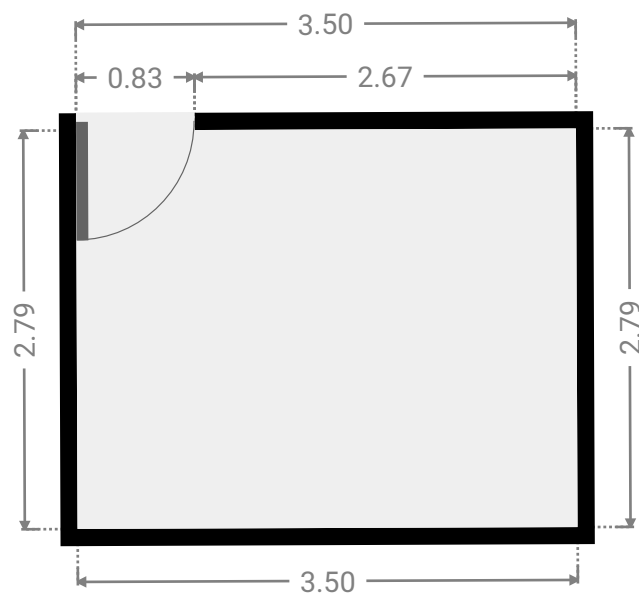
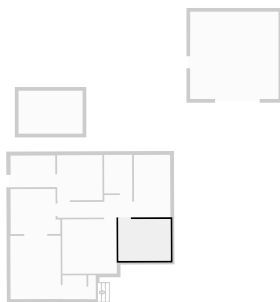

▼ **Bedroom**
Ground Floor

WIDTH: 2.43 m • LENGTH: 4.19 m
AREA: 10.19 m² • PERIMETER: 13.24 m

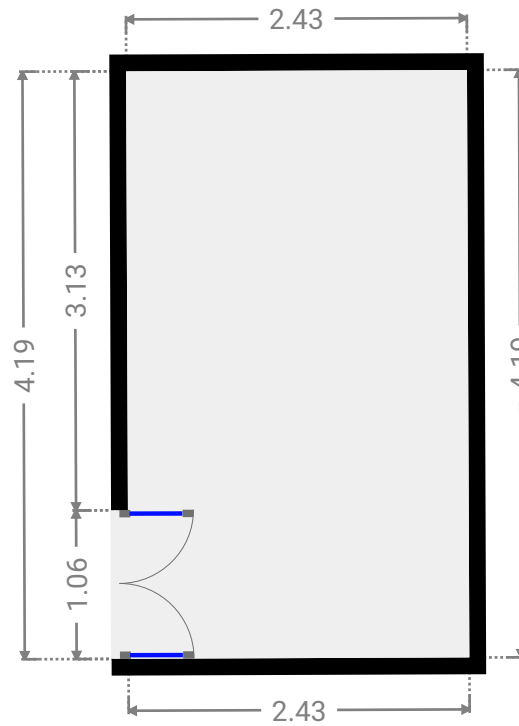
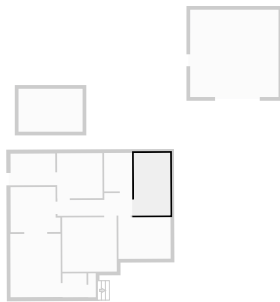

▼ **Bathroom**
Ground Floor

WIDTH: 1.88 m • LENGTH: 2.58 m
AREA: 4.85 m² • PERIMETER: 8.92 m

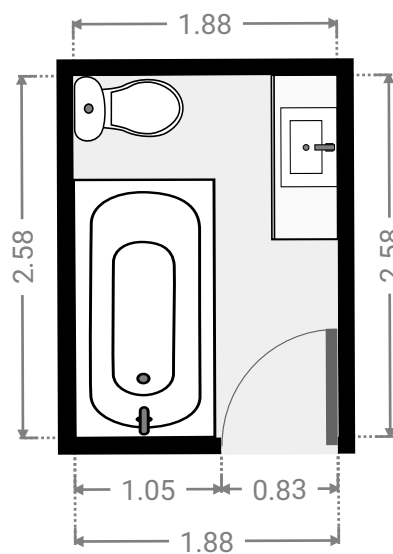
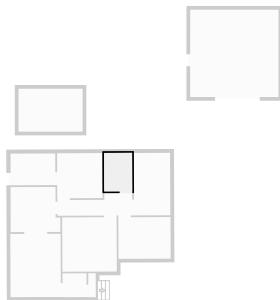

▼ **Kitchen**
Ground Floor

WIDTH: 3.04 m • LENGTH: 3.04 m
AREA: 9.18 m² • PERIMETER: 12.12 m

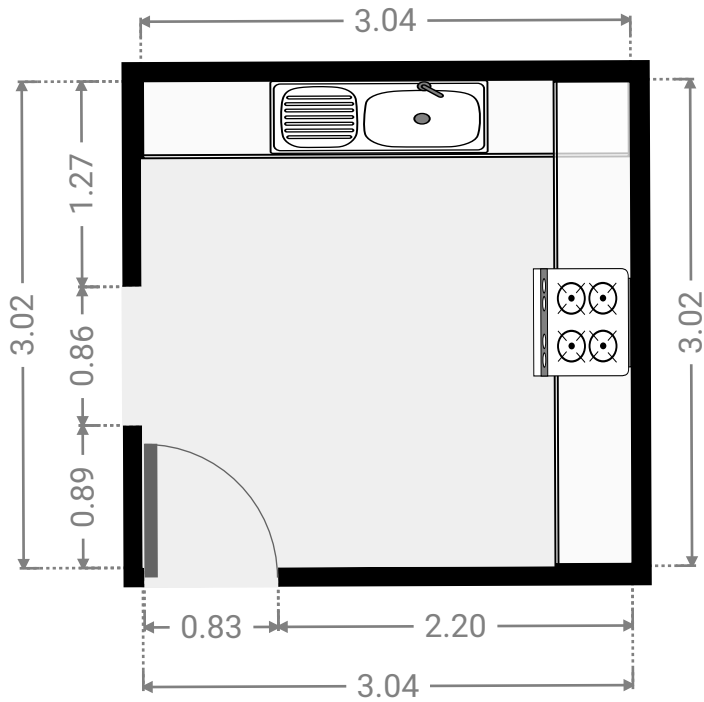
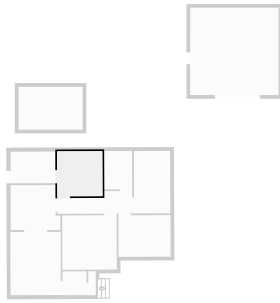

▼ **Laundry Room**
Ground Floor

WIDTH: 3.00 m • LENGTH: 2.12 m
AREA: 6.37 m² • PERIMETER: 10.25 m

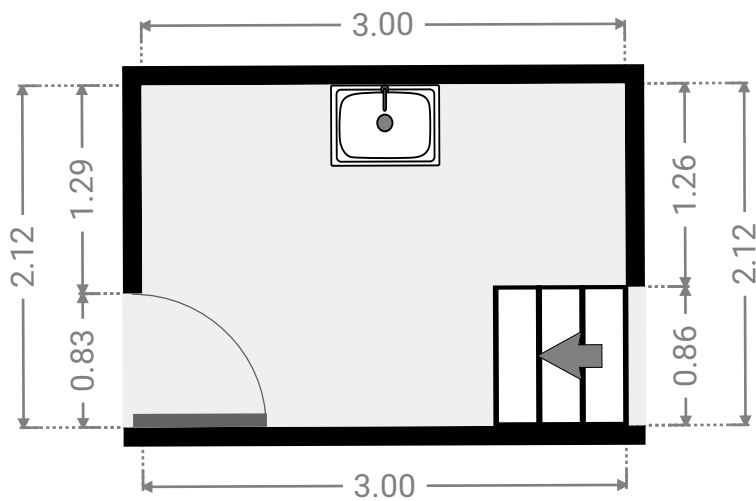
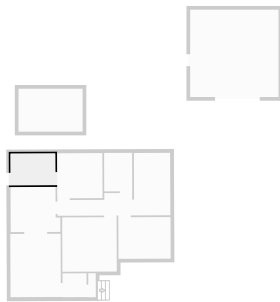

▼ **Hall**
Ground Floor

WIDTH: 0.50 m • LENGTH: 1.61 m
AREA: 0.80 m² • PERIMETER: 4.22 m

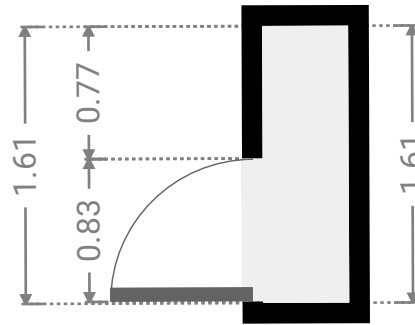
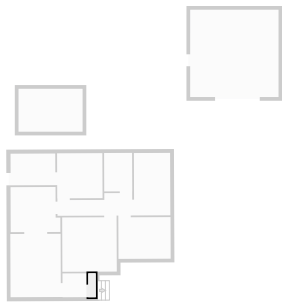

▼ **Garage**
Ground Floor

WIDTH: 4.30 m • LENGTH: 2.88 m
AREA: 12.38 m² • PERIMETER: 14.36 m

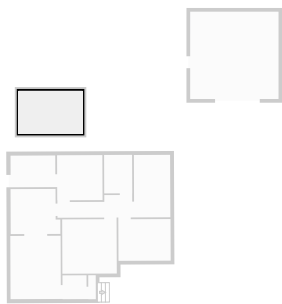

▼ **Garage**
Ground Floor

WIDTH: 5.93 m • LENGTH: 5.86 m
AREA: 34.75 m² • PERIMETER: 23.58 m

