

# 46 Kent Street

Created on  
2021-03-16

Floors  
2

## ▼ Ground Floor



## ▼ Living Room Ground Floor

WIDTH: 4.04 m • LENGTH: 6.67 m  
AREA: 23.95 m<sup>2</sup> • PERIMETER: 21.42 m

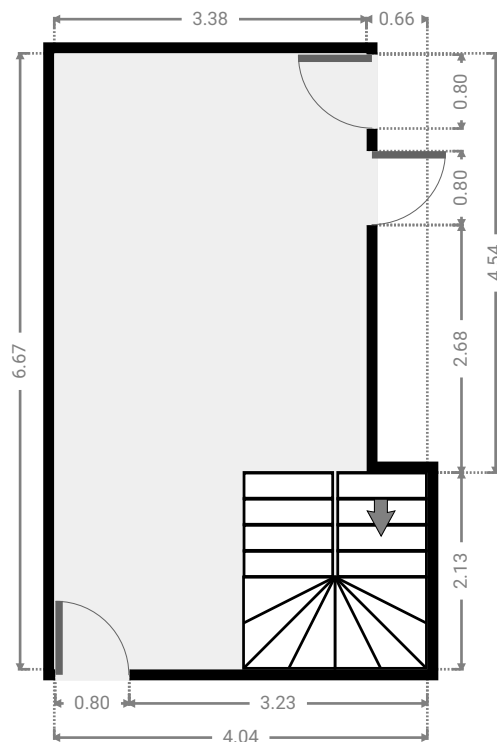

## ▼ Bedroom Ground Floor

WIDTH: 3.52 m • LENGTH: 3.47 m  
AREA: 12.21 m<sup>2</sup> • PERIMETER: 13.98 m

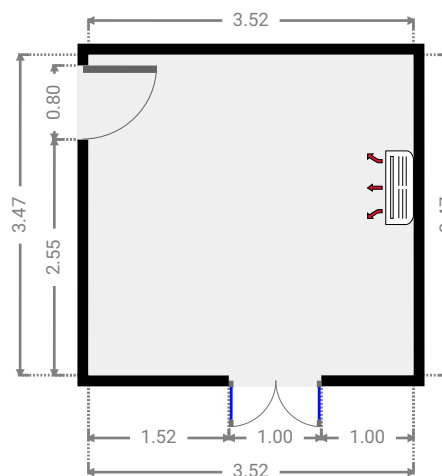

▼ Closet  
Ground Floor

WIDTH: 2.85 m • LENGTH: 2.12 m  
AREA: 6.05 m<sup>2</sup> • PERIMETER: 9.95 m

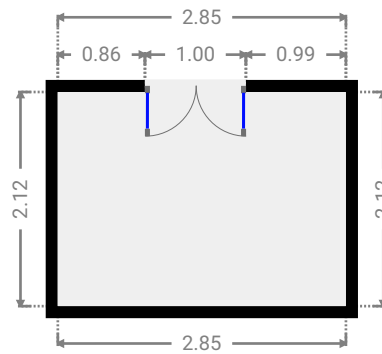

▼ Kitchen  
Ground Floor

WIDTH: 7.10 m • LENGTH: 5.22 m  
AREA: 23.13 m<sup>2</sup> • PERIMETER: 24.64 m

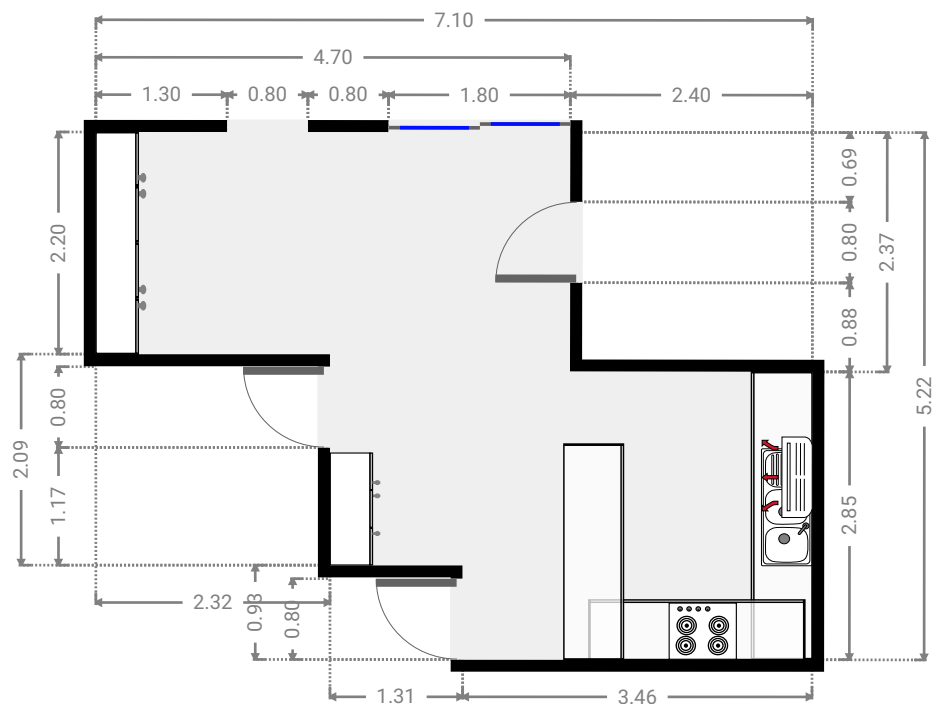
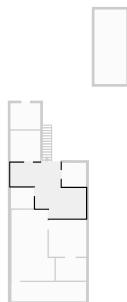

▼ **Bedroom**  
Ground Floor

WIDTH: 2.15 m • LENGTH: 1.97 m  
AREA: 4.23 m<sup>2</sup> • PERIMETER: 8.24 m

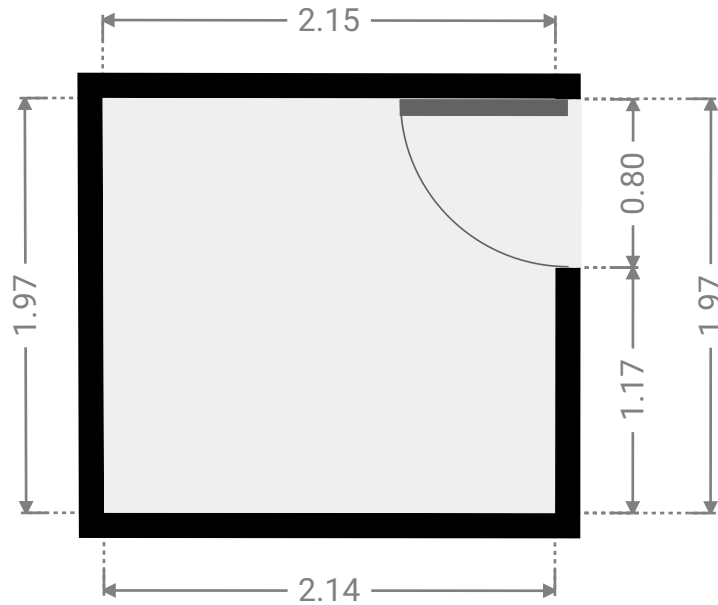

▼ **Bathroom**  
Ground Floor

WIDTH: 2.28 m • LENGTH: 2.25 m  
AREA: 5.13 m<sup>2</sup> • PERIMETER: 9.06 m

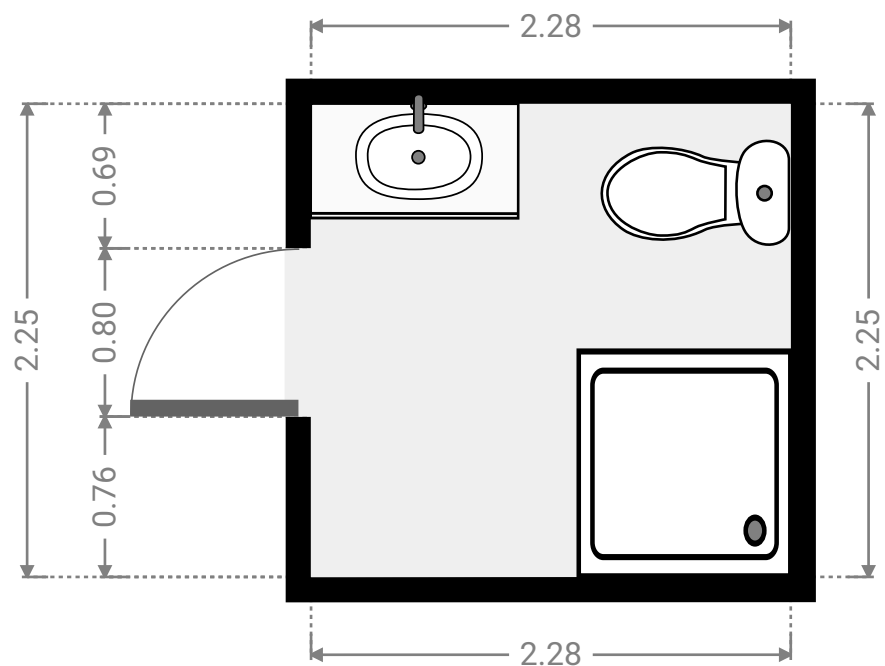
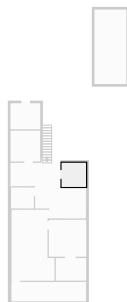

▼ **Bedroom**  
Ground Floor

WIDTH: 2.78 m • LENGTH: 2.90 m  
AREA: 8.06 m<sup>2</sup> • PERIMETER: 11.36 m

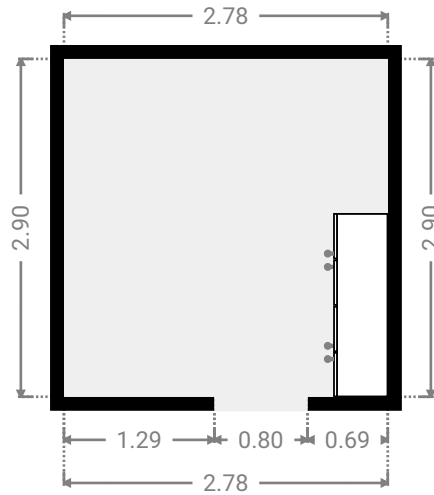

▼ **Other**  
Ground Floor

WIDTH: 7.02 m • LENGTH: 1.83 m  
AREA: 12.81 m<sup>2</sup> • PERIMETER: 17.68 m

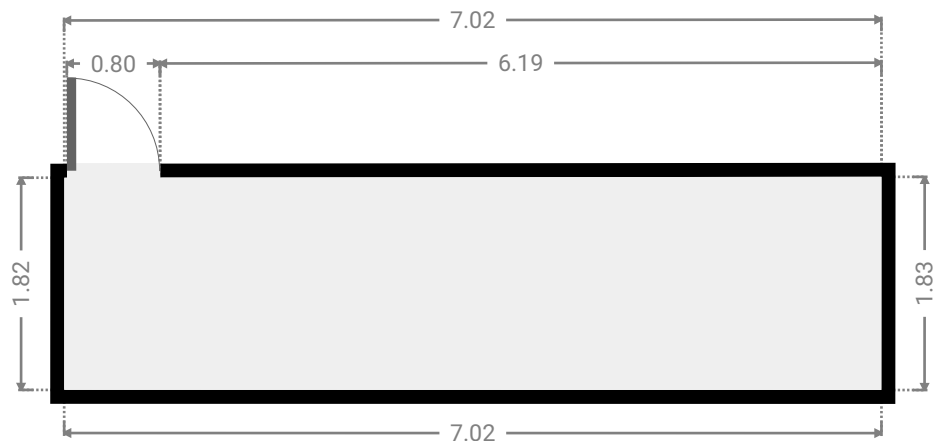

▼ Laundry Room  
Ground Floor

WIDTH: 2.80 m • LENGTH: 2.45 m  
AREA: 6.86 m<sup>2</sup> • PERIMETER: 10.50 m

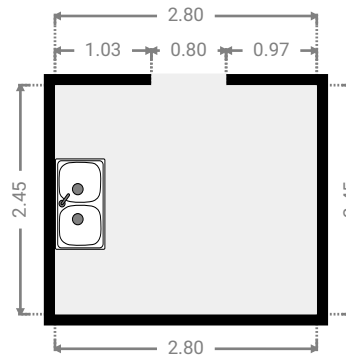
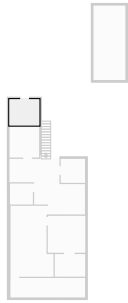

▼ Garage  
Ground Floor

WIDTH: 3.00 m • LENGTH: 7.00 m  
AREA: 21.00 m<sup>2</sup> • PERIMETER: 20.00 m

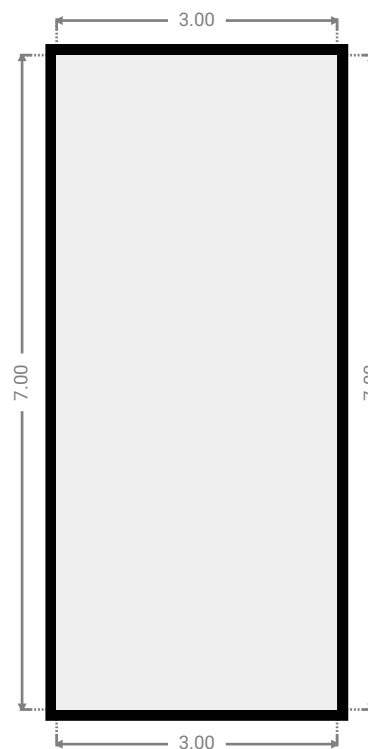

▼ 1st Floor

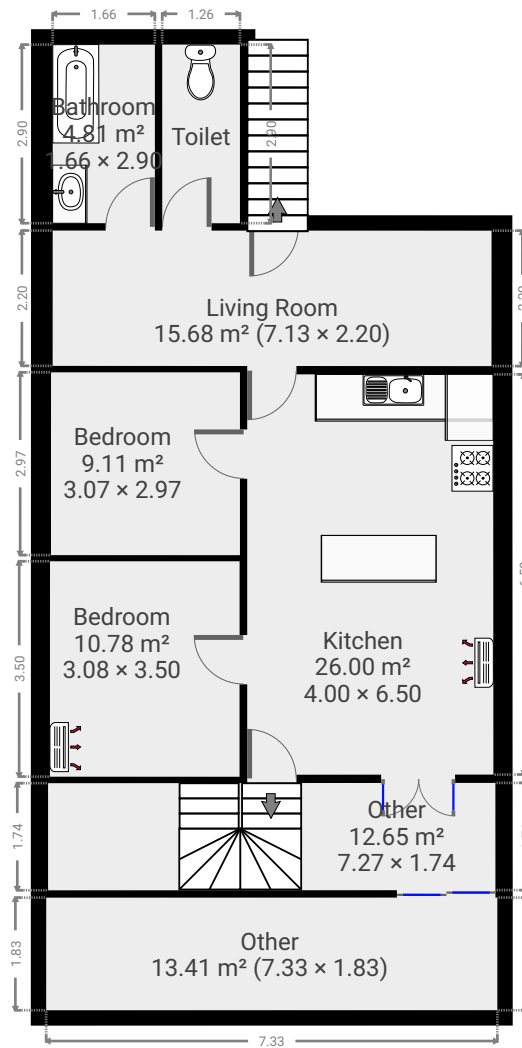



▼ Other  
1st Floor

WIDTH: 7.33 m • LENGTH: 1.83 m  
AREA: 13.41 m<sup>2</sup> • PERIMETER: 18.32 m

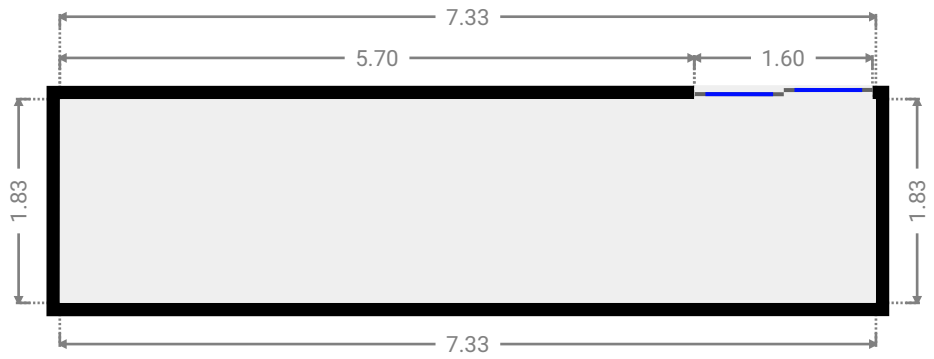
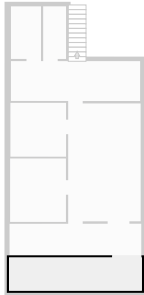

▼ Other  
1st Floor

WIDTH: 7.33 m • LENGTH: 1.74 m  
AREA: 12.65 m<sup>2</sup> • PERIMETER: 18.02 m

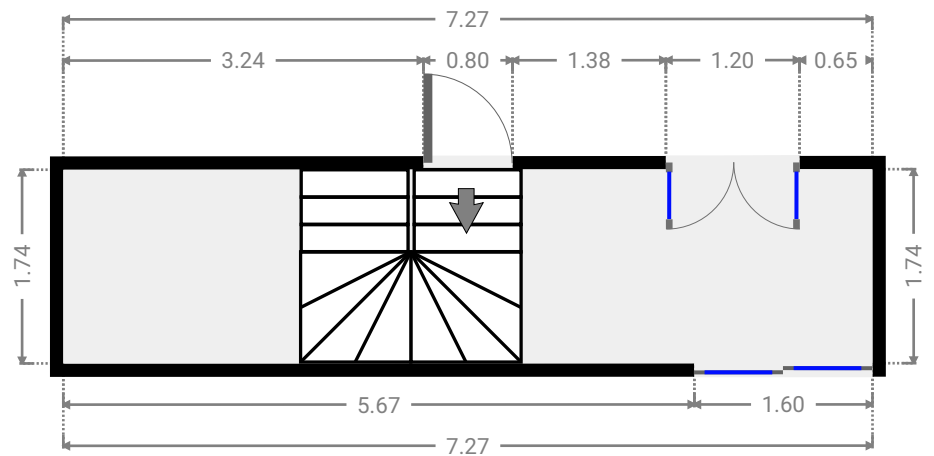
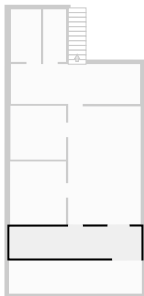

## ▼ Kitchen 1st Floor

WIDTH: 4.00 m • LENGTH: 6.50 m  
AREA: 26.00 m<sup>2</sup> • PERIMETER: 21.00 m

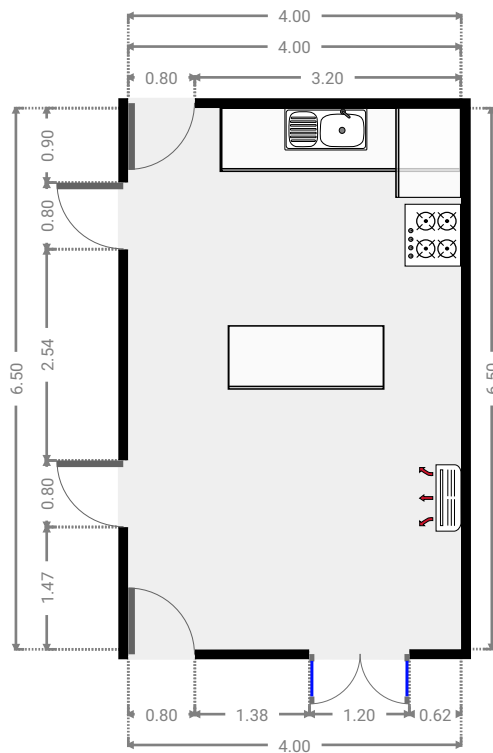
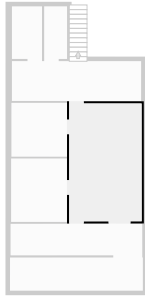

## ▼ Bedroom 1st Floor

WIDTH: 3.08 m • LENGTH: 3.50 m  
AREA: 10.78 m<sup>2</sup> • PERIMETER: 13.16 m

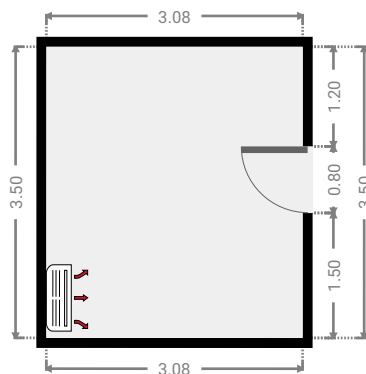
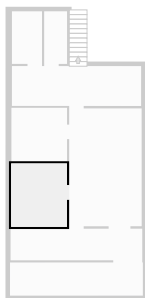

▼ **Bedroom**  
1st Floor

WIDTH: 3.07 m • LENGTH: 2.97 m  
AREA: 9.11 m<sup>2</sup> • PERIMETER: 12.08 m

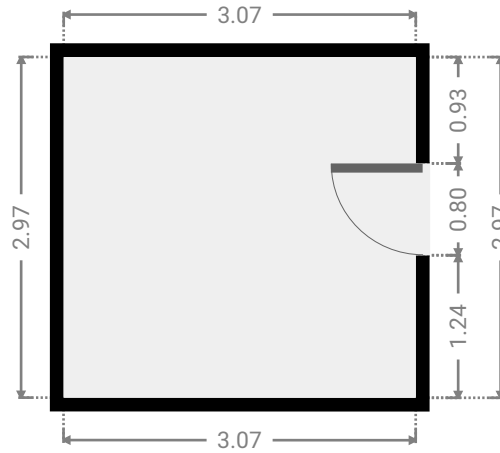
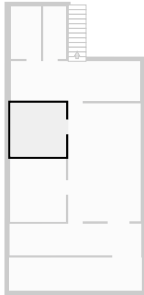

▼ **Living Room**  
1st Floor

WIDTH: 7.13 m • LENGTH: 2.20 m  
AREA: 15.68 m<sup>2</sup> • PERIMETER: 18.66 m

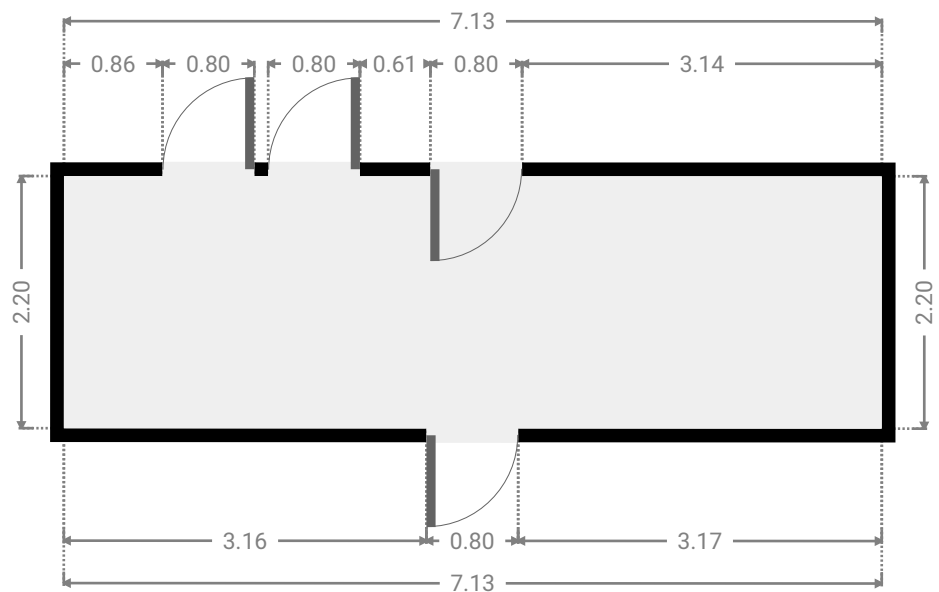
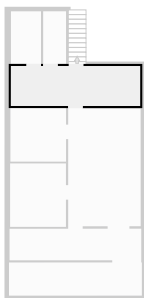

▼ **Bathroom**  
1st Floor

WIDTH: 1.66 m • LENGTH: 2.90 m  
AREA: 4.81 m<sup>2</sup> • PERIMETER: 9.12 m

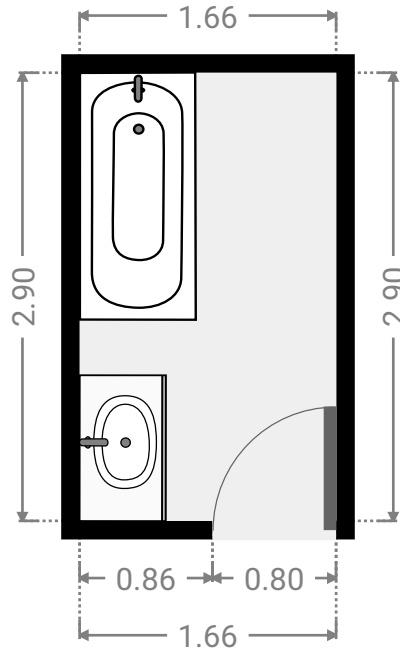
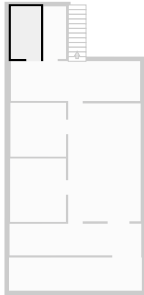

▼ **Toilet**  
1st Floor

WIDTH: 1.26 m • LENGTH: 2.90 m  
AREA: 3.66 m<sup>2</sup> • PERIMETER: 8.33 m

