

44 Stenlake Avenue

SUBMITTED BY
Ray White Rockhampton Casey
stockers@cqoz.com

CREATED ON
2022-05-17

Floors 1

▼ Ground Floor



FLOORS: 1

▼ **Bathroom**
Ground Floor

WIDTH: 1.93 m • LENGTH: 2.05 m
AREA: 3.96 m² • PERIMETER: 7.96 m

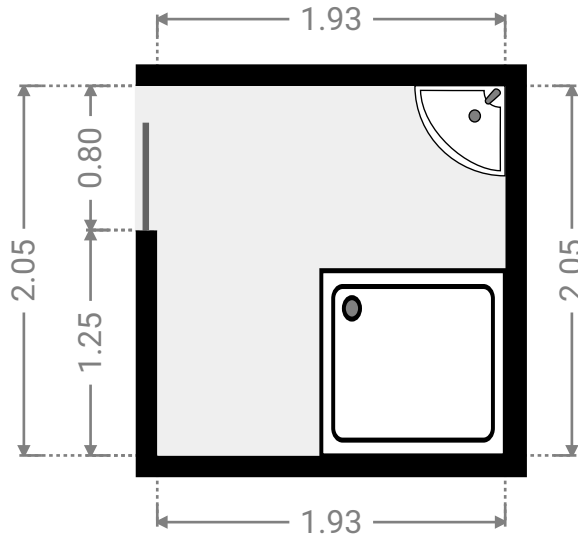
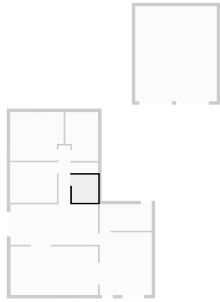

▼ **Bedroom**
Ground Floor

WIDTH: 3.45 m • LENGTH: 2.98 m
AREA: 10.28 m² • PERIMETER: 12.86 m

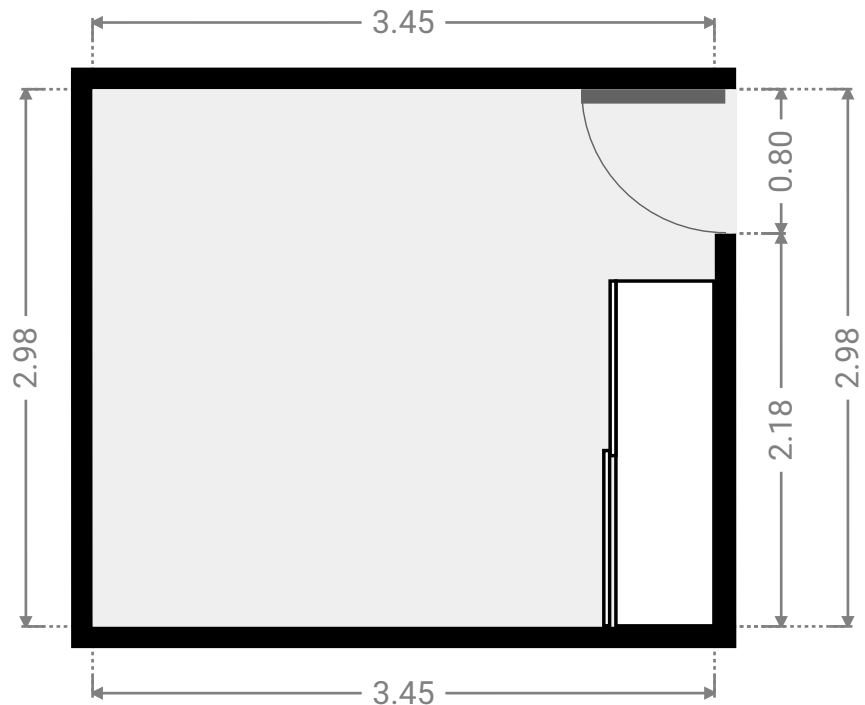
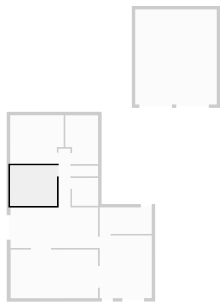

FLOORS: 1

▼ **Bedroom**
Ground Floor

WIDTH: 3.94 m • LENGTH: 3.58 m
AREA: 13.48 m² • PERIMETER: 15.04 m

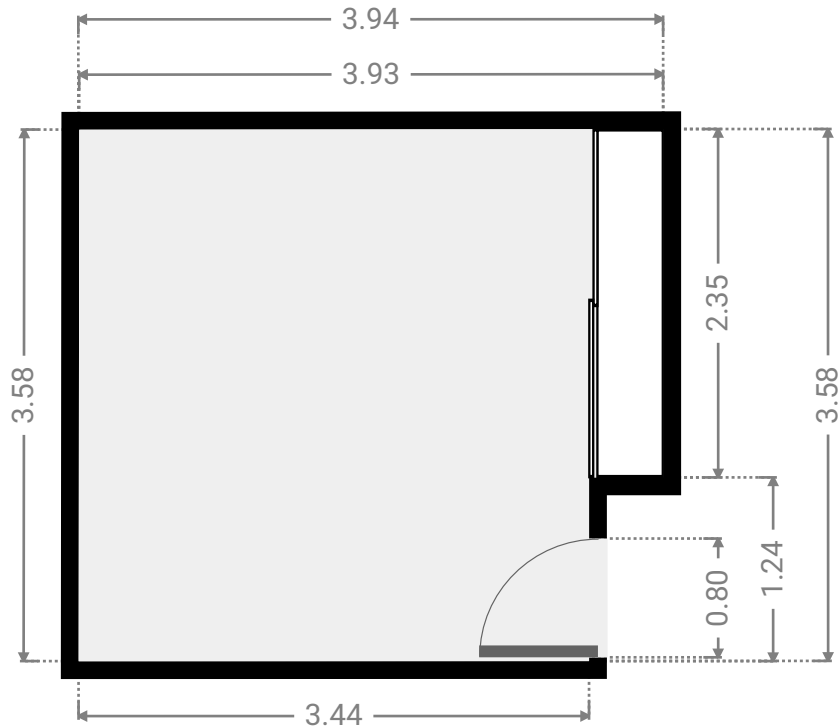
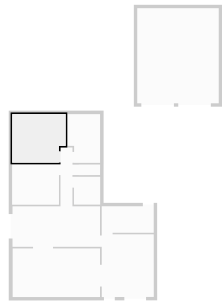

▼ **Bedroom**
Ground Floor

WIDTH: 2.41 m • LENGTH: 3.59 m
AREA: 8.03 m² • PERIMETER: 12.00 m

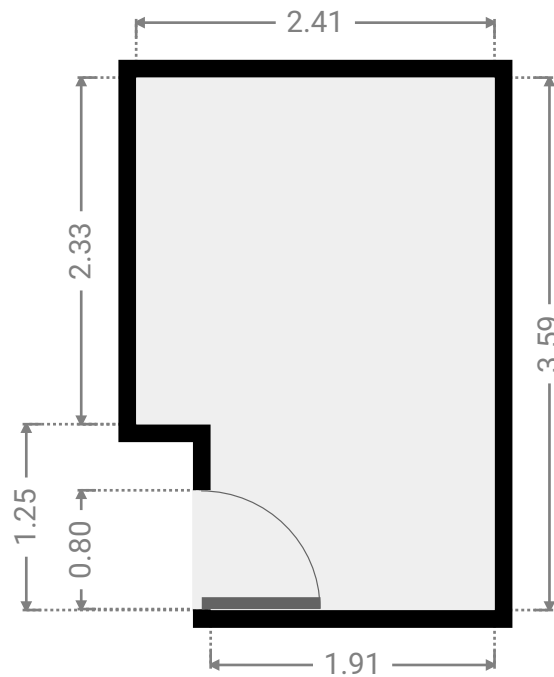
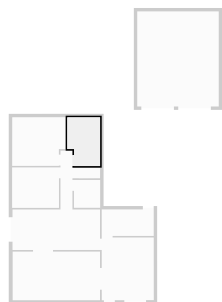

FLOORS: 1

▼ Garage
Ground Floor

WIDTH: 6.00 m • LENGTH: 7.00 m
AREA: 42.00 m² • PERIMETER: 26.00 m

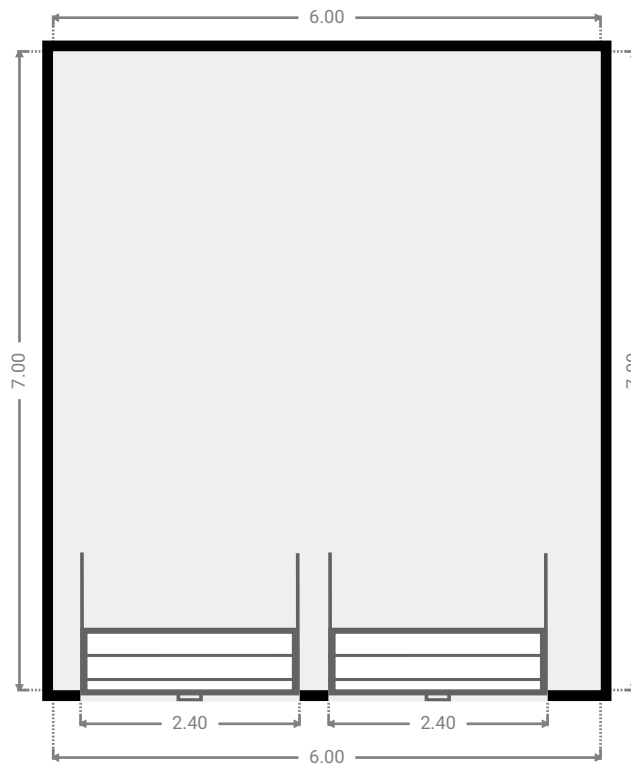
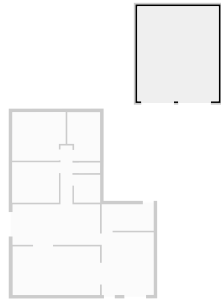

▼ Hall
Ground Floor

WIDTH: 1.23 m • LENGTH: 4.21 m
AREA: 3.98 m² • PERIMETER: 10.87 m

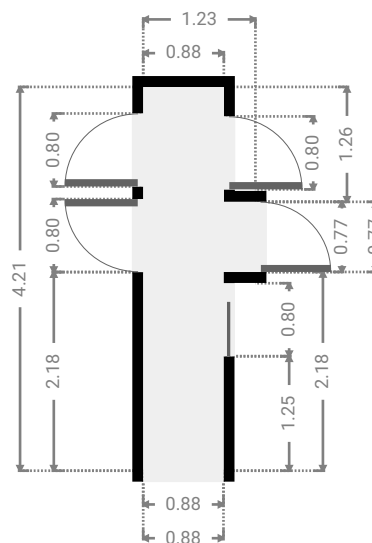
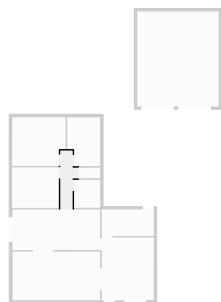

FLOORS: 1

▼ **Kitchen**
Ground Floor

WIDTH: 6.44 m • LENGTH: 2.98 m
AREA: 19.19 m² • PERIMETER: 18.84 m

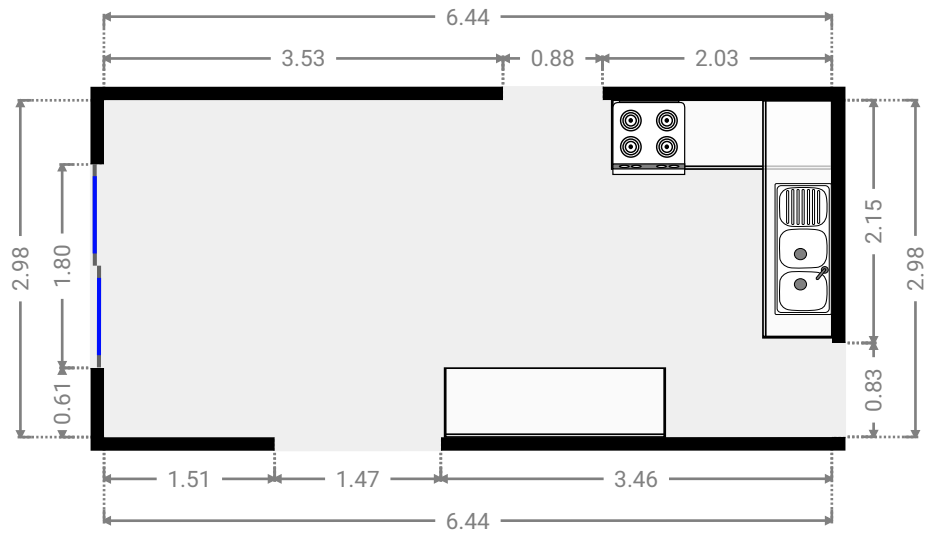
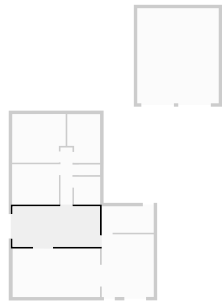

▼ **Laundry Room**
Ground Floor

WIDTH: 3.83 m • LENGTH: 1.95 m
AREA: 7.47 m² • PERIMETER: 11.56 m

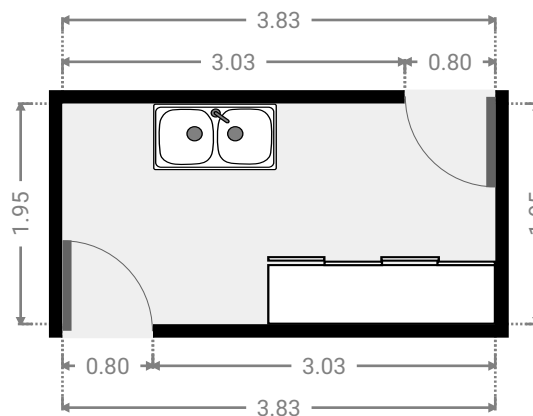
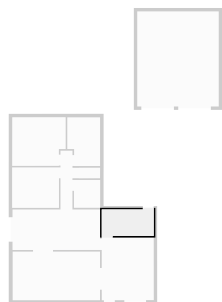

FLOORS: 1

▼ Living Room
Ground Floor

WIDTH: 3.83 m • LENGTH: 4.62 m
AREA: 17.68 m² • PERIMETER: 16.89 m

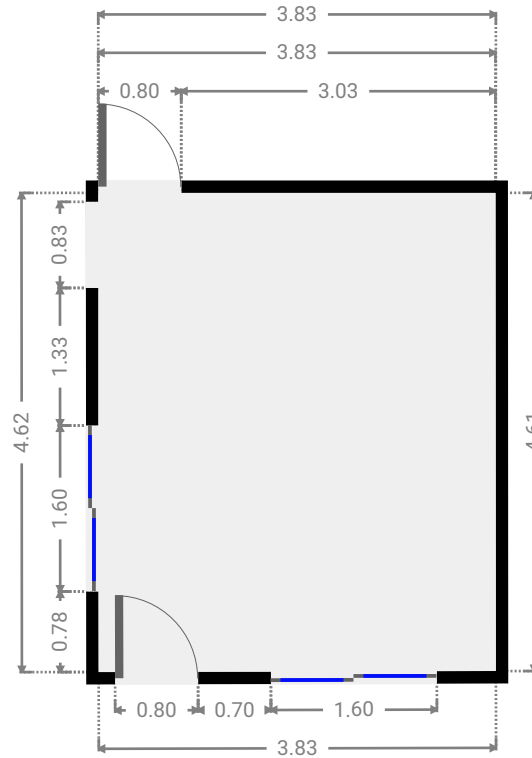
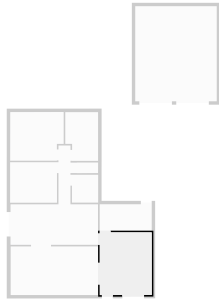

▼ Living Room
Ground Floor

WIDTH: 6.43 m • LENGTH: 3.58 m
AREA: 23.02 m² • PERIMETER: 20.02 m

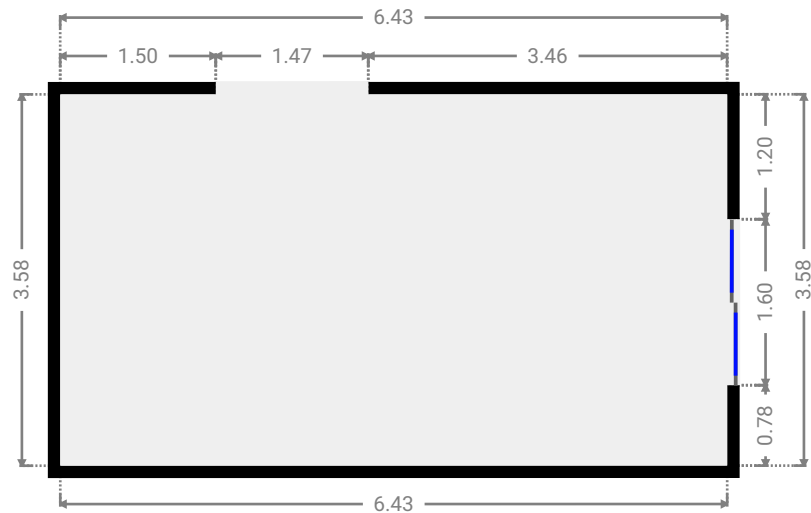
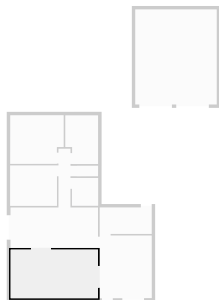

FLOORS: 1

▼ Toilet
Ground Floor

WIDTH: 1.57 m • LENGTH: 0.79 m
AREA: 1.22 m² • PERIMETER: 4.69 m

