

44 Jamie Crescent

Created on
2021-03-02

Floors
1



▼ Ground Floor

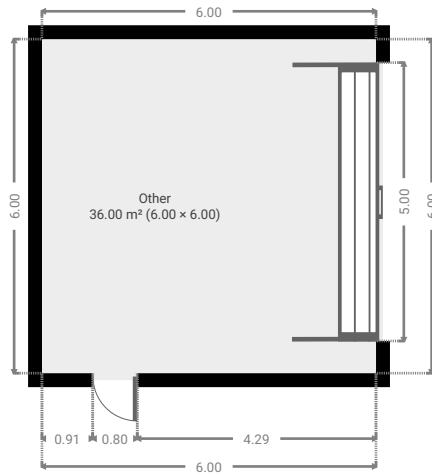

▼ Bedroom
Ground Floor

WIDTH: 3.16 m • LENGTH: 3.60 m
AREA: 10.72 m² • PERIMETER: 13.53 m

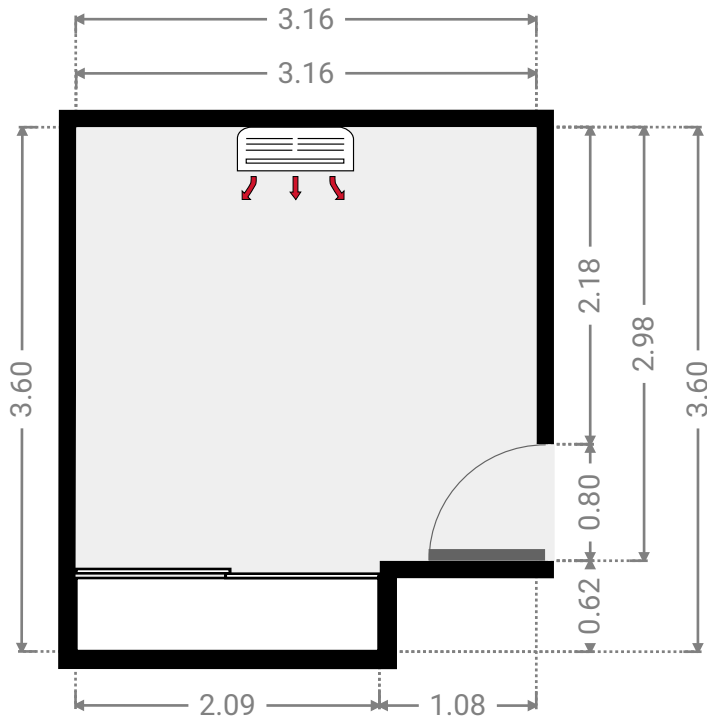
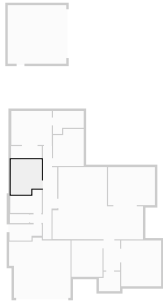

▼ Other
Ground Floor

WIDTH: 2.17 m • LENGTH: 2.00 m
AREA: 4.02 m² • PERIMETER: 8.34 m

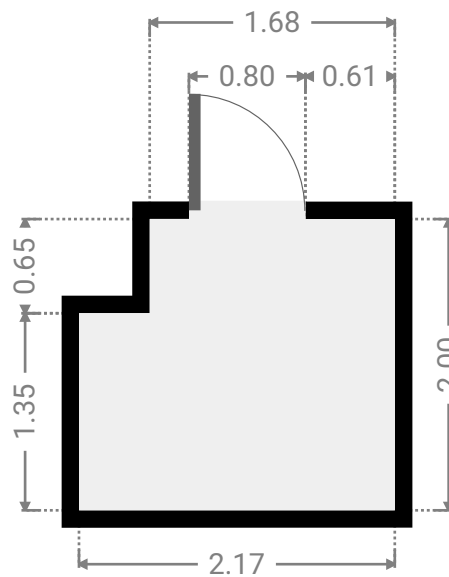
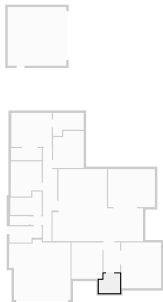

▼ Garage Ground Floor

WIDTH: 6.30 m • LENGTH: 6.17 m
AREA: 35.37 m² • PERIMETER: 24.93 m

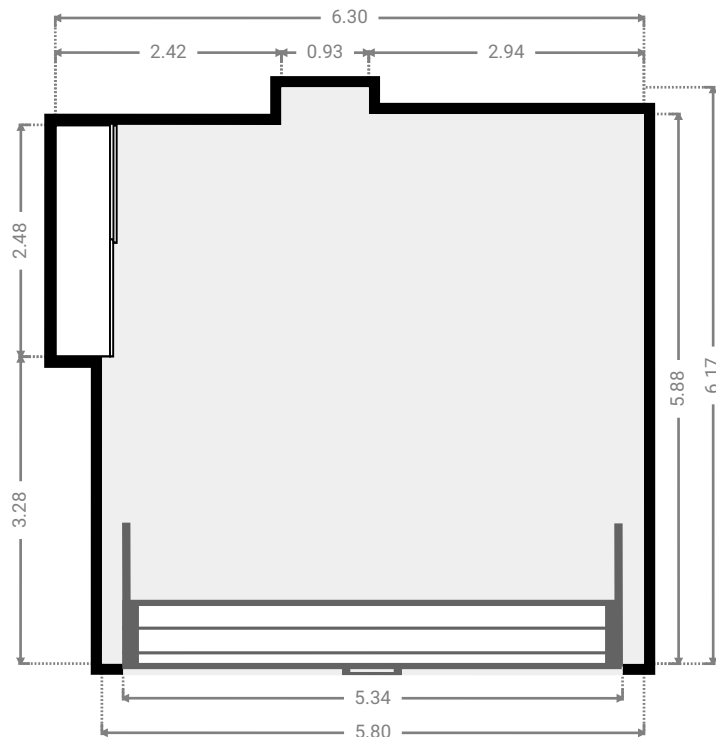
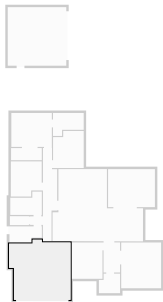

▼ Other Ground Floor

WIDTH: 6.00 m • LENGTH: 6.00 m
AREA: 36.00 m² • PERIMETER: 24.00 m

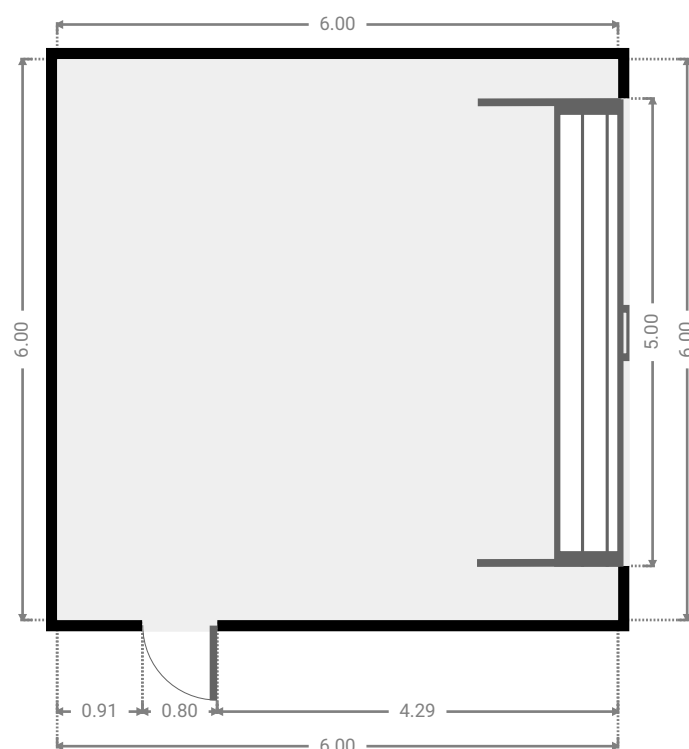

▼ Other Ground Floor

WIDTH: 4.80 m • LENGTH: 3.89 m
AREA: 18.69 m² • PERIMETER: 17.39 m

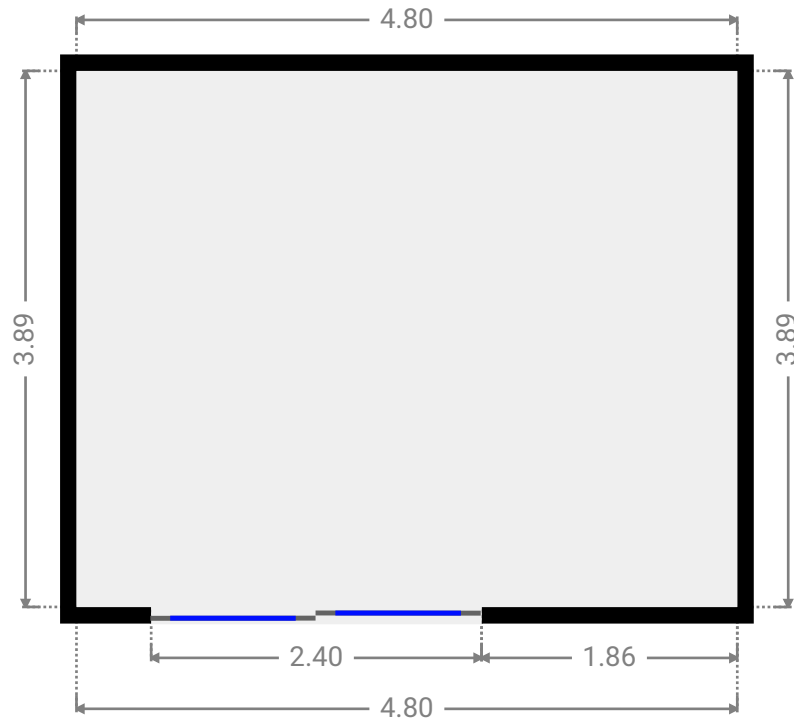
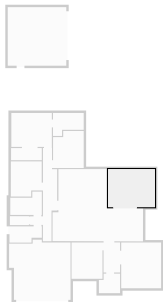

▼ Bathroom Ground Floor

WIDTH: 3.15 m • LENGTH: 2.36 m
AREA: 6.01 m² • PERIMETER: 11.00 m

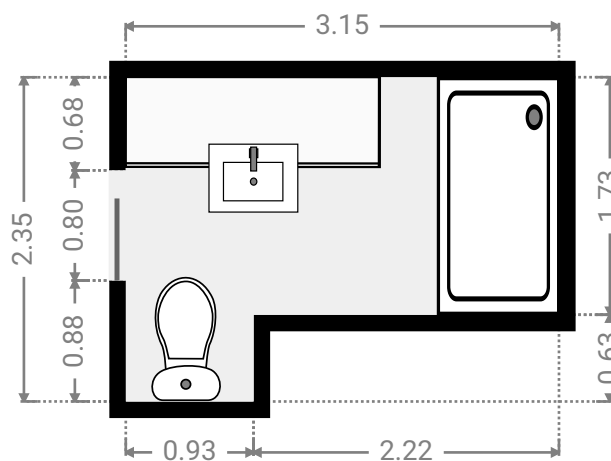
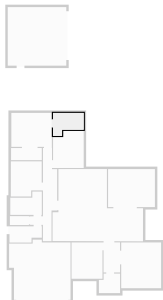

▼ **Bedroom**
Ground Floor

WIDTH: 3.14 m • LENGTH: 3.80 m
AREA: 11.28 m² • PERIMETER: 13.88 m

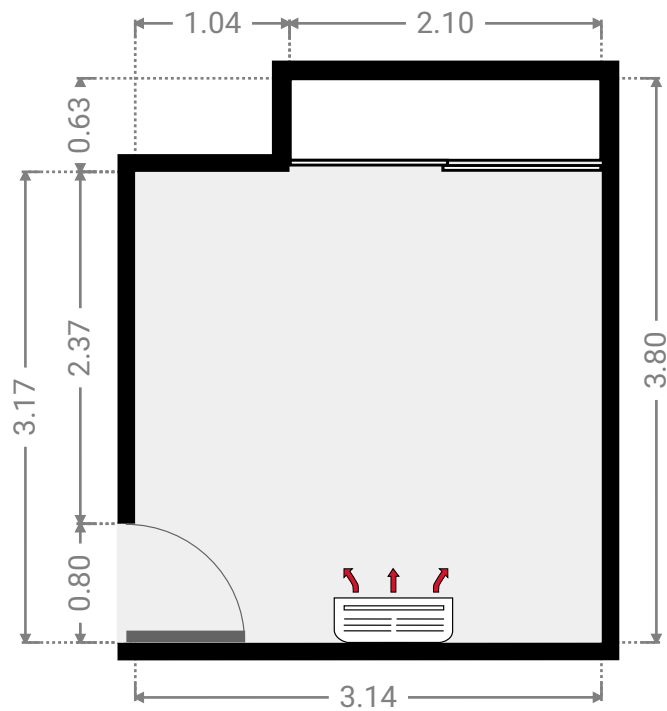
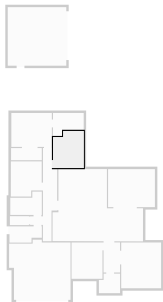

▼ **Master Bedroom**
Ground Floor

WIDTH: 4.15 m • LENGTH: 3.48 m
AREA: 14.44 m² • PERIMETER: 15.26 m

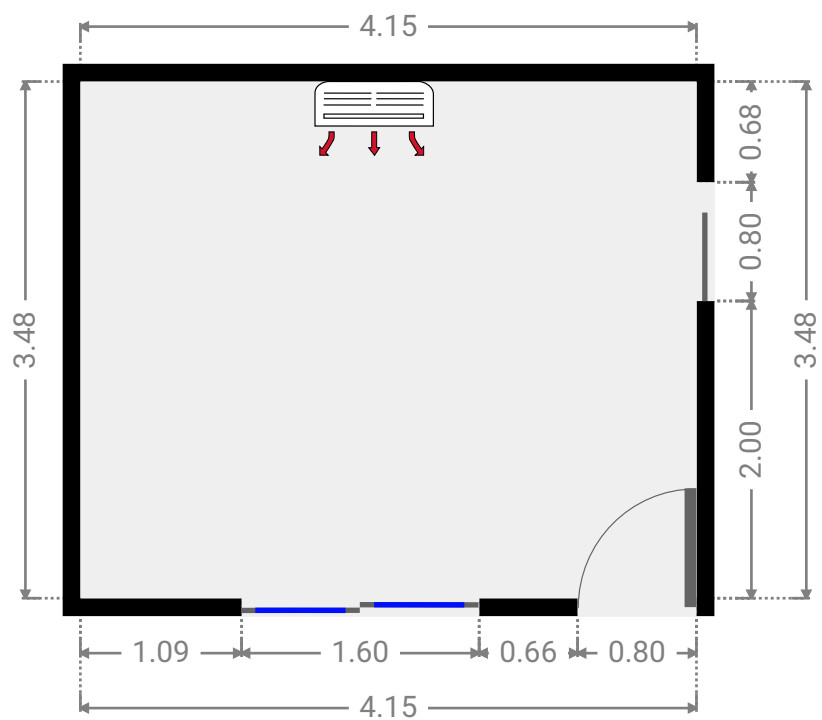
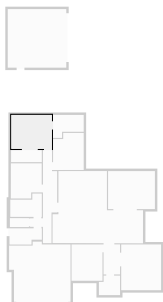

FLOORS: 1

▼ Closet Ground Floor

WIDTH: 3.15 m • LENGTH: 1.24 m
AREA: 3.91 m² • PERIMETER: 8.78 m

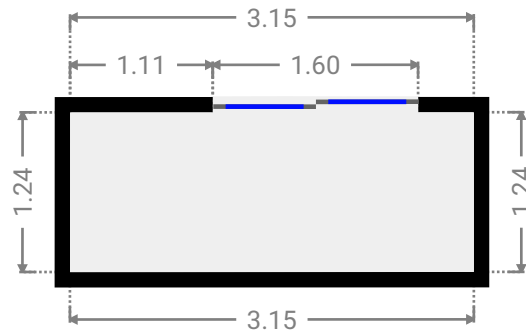
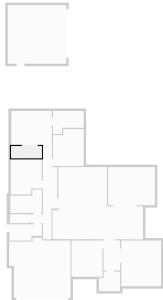

▼ Living Room Ground Floor

WIDTH: 4.09 m • LENGTH: 4.69 m
AREA: 19.18 m² • PERIMETER: 17.56 m

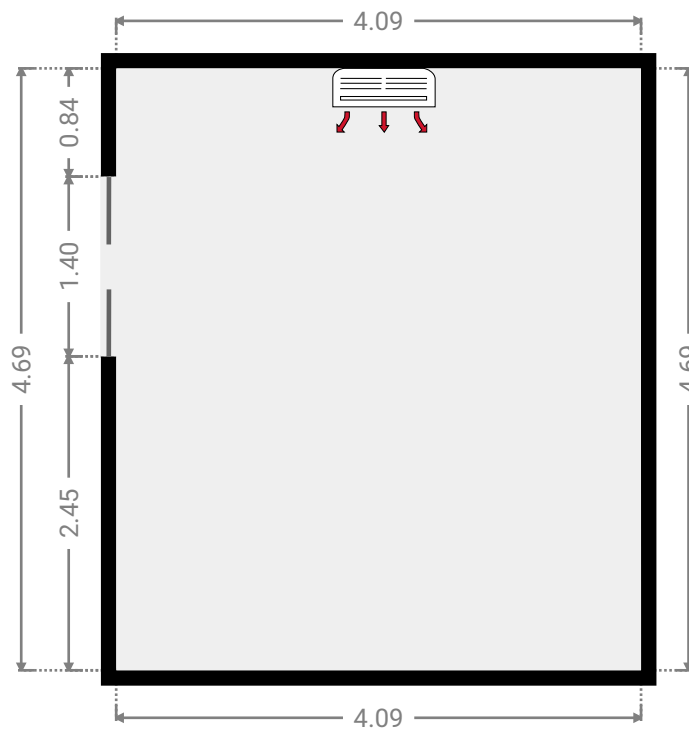
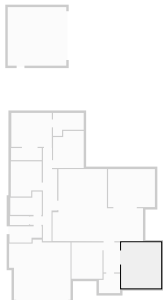

▼ Bathroom
Ground Floor

WIDTH: 3.23 m • LENGTH: 2.39 m
AREA: 6.30 m² • PERIMETER: 11.24 m

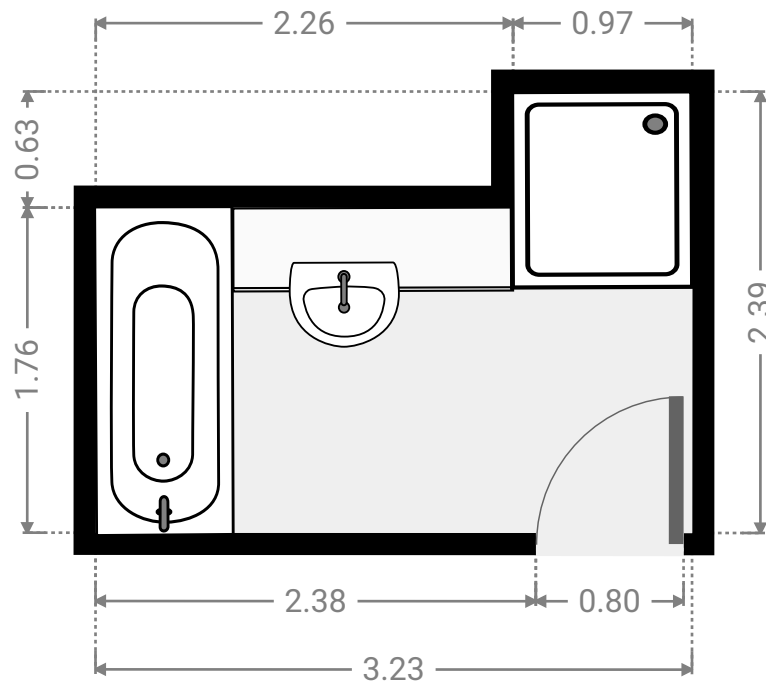
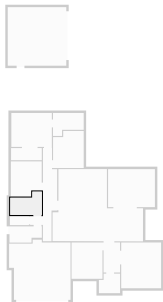

▼ Toilet
Ground Floor

WIDTH: 1.95 m • LENGTH: 0.92 m
AREA: 1.78 m² • PERIMETER: 5.73 m

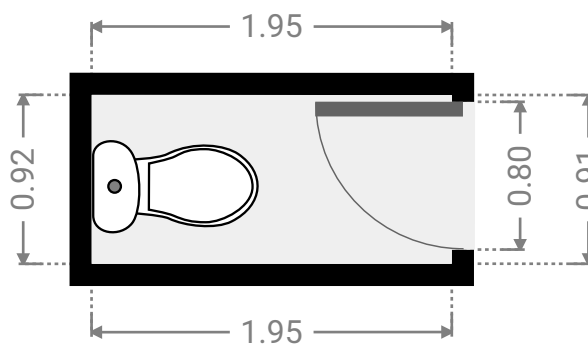

▼ Hall
Ground Floor

WIDTH: 1.20 m • LENGTH: 0.87 m
AREA: 1.04 m² • PERIMETER: 4.14 m

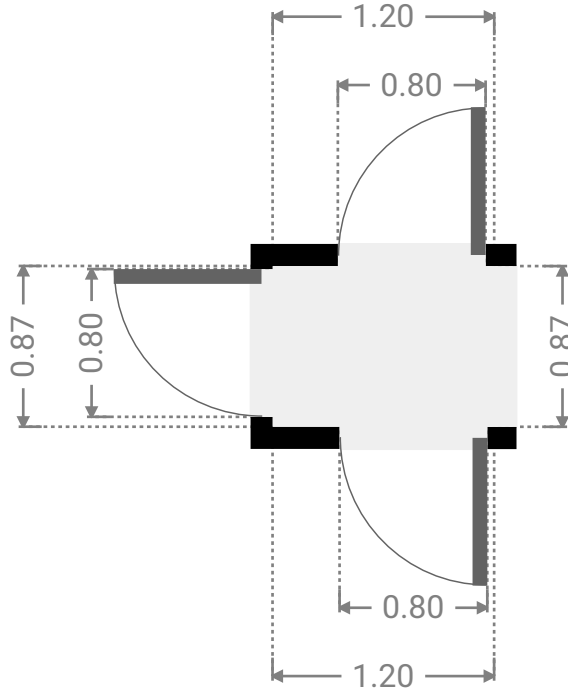
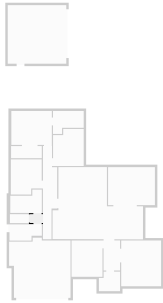

▼ Laundry Room
Ground Floor

WIDTH: 3.31 m • LENGTH: 1.66 m
AREA: 4.97 m² • PERIMETER: 9.95 m

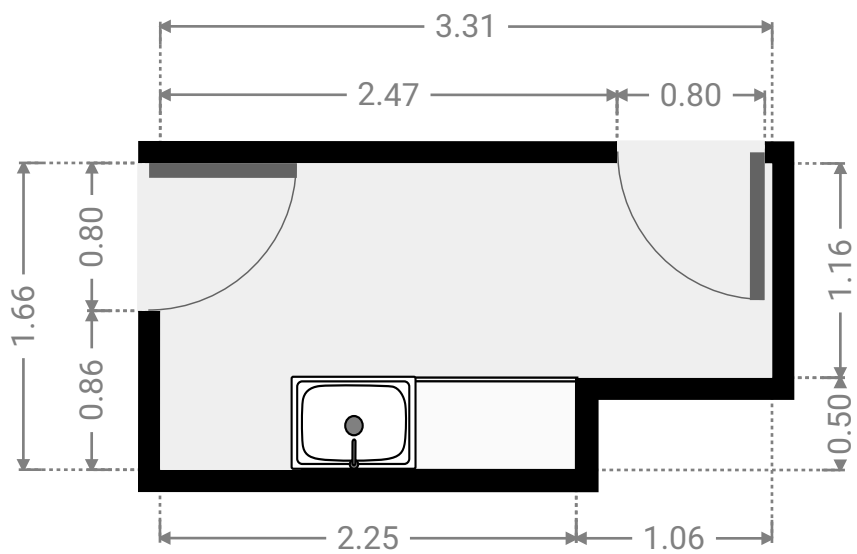
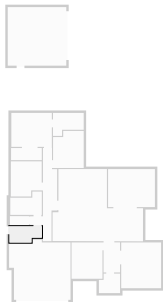

▼ Hall Ground Floor

WIDTH: 1.46 m • LENGTH: 9.56 m
AREA: 10.96 m² • PERIMETER: 22.04 m

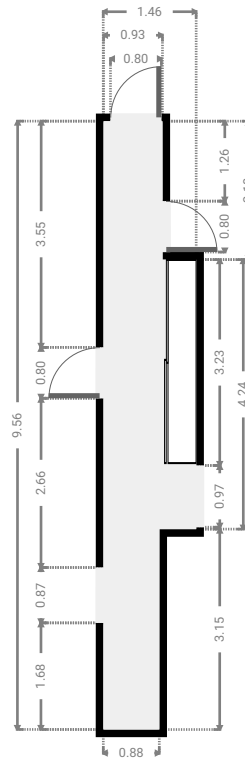
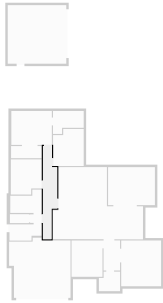

▼ Kitchen Ground Floor

WIDTH: 9.27 m • LENGTH: 7.41 m
AREA: 51.01 m² • PERIMETER: 33.33 m

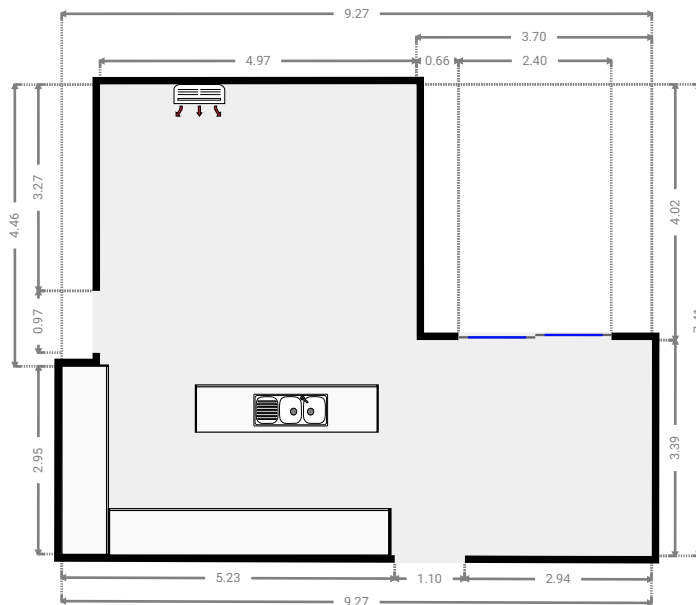
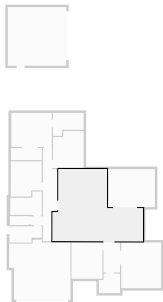

▼ **Bedroom**
Ground Floor

WIDTH: 3.17 m • LENGTH: 3.72 m
AREA: 11.79 m² • PERIMETER: 13.78 m

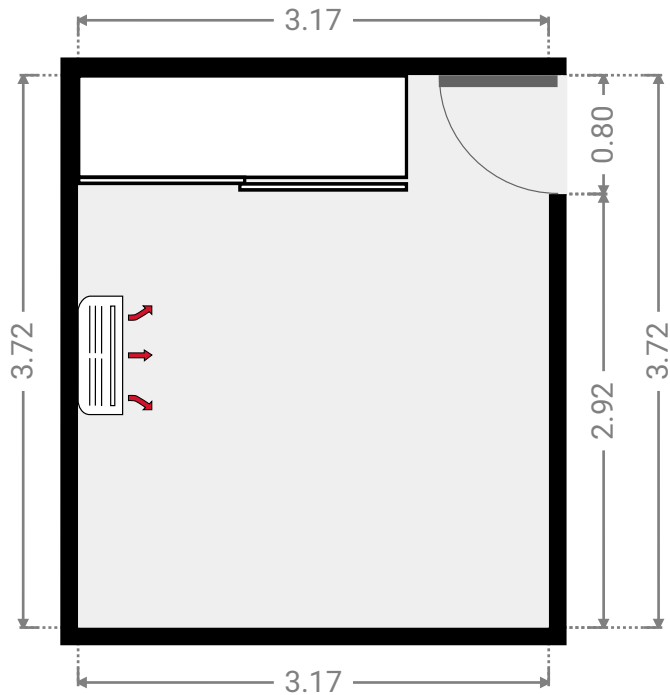
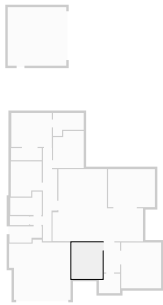

▼ **Hall**
Ground Floor

WIDTH: 1.69 m • LENGTH: 3.08 m
AREA: 5.21 m² • PERIMETER: 9.54 m

