

44 Coronation Drive , Horse Creek

SUBMITTED BY

Ray White Rockhampton Casey
stockers@cqoz.com

CREATED ON

2022-12-19

Floors

2

FLOORS: 2

▼ Ground Floor



THIS FLOORPLAN IS PROVIDED WITHOUT WARRANTY OF ANY KIND. SENSOPIA DISCLAIMS ANY WARRANTY INCLUDING, WITHOUT LIMITATION, SATISFACTORY QUALITY OR ACCURACY OF DIMENSIONS.

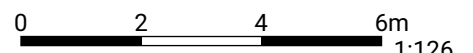

FLOORS: 2

▼ **Bathroom**
Ground Floor

WIDTH: 1.37 m • LENGTH: 3.19 m
AREA: 4.37 m² • PERIMETER: 9.12 m

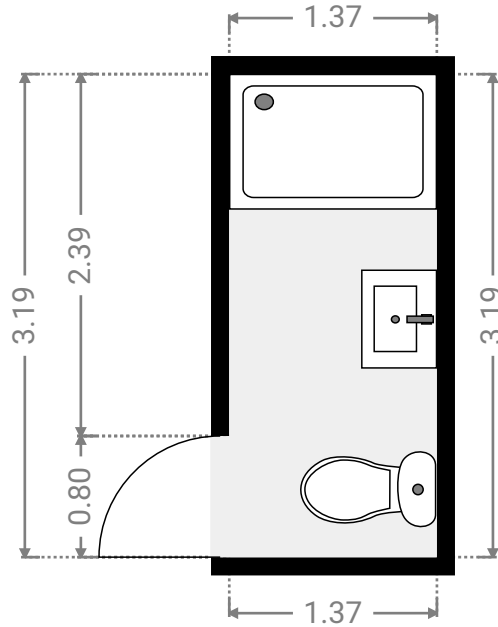
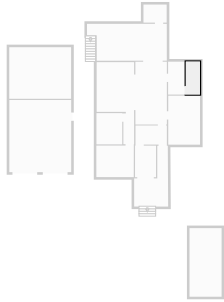

▼ **Bedroom**
Ground Floor

WIDTH: 2.04 m • LENGTH: 3.06 m
AREA: 6.24 m² • PERIMETER: 10.20 m

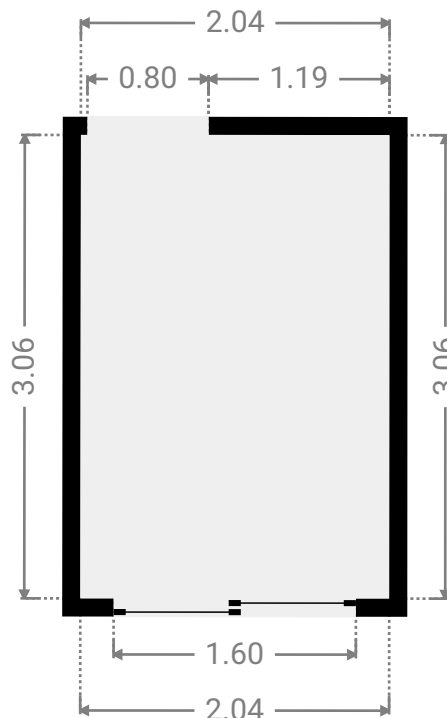
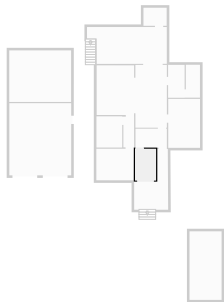

FLOORS: 2

▼ **Bedroom**
Ground Floor

WIDTH: 3.08 m • LENGTH: 4.75 m
AREA: 14.63 m² • PERIMETER: 15.66 m

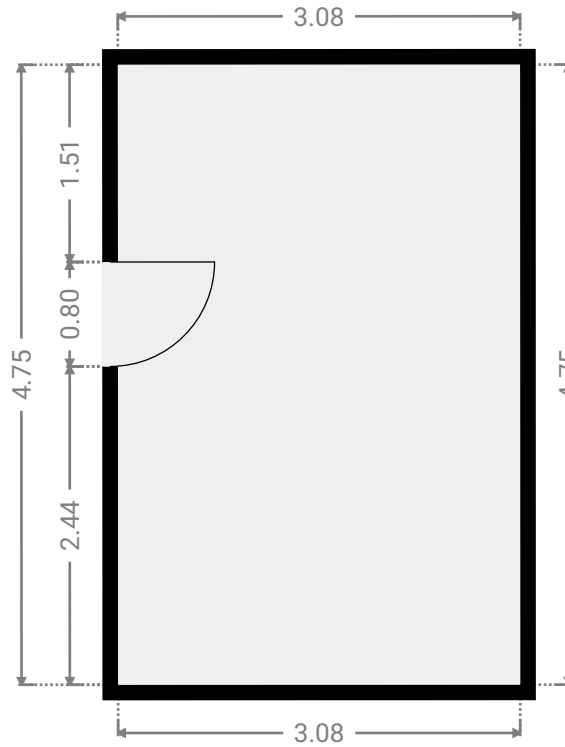
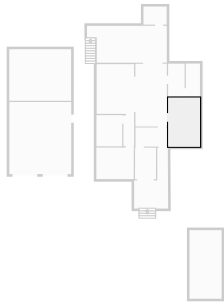

▼ **Bedroom**
Ground Floor

WIDTH: 2.50 m • LENGTH: 3.03 m
AREA: 7.57 m² • PERIMETER: 11.06 m

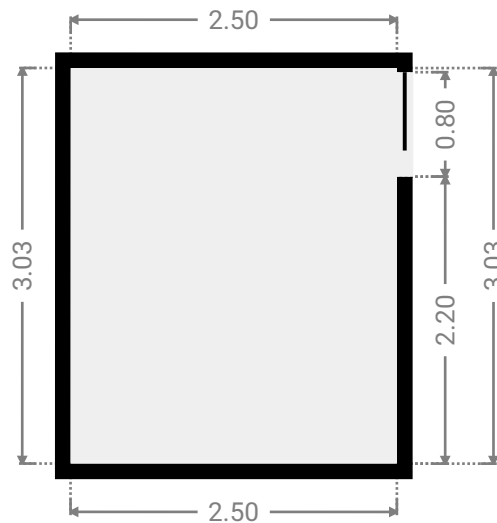
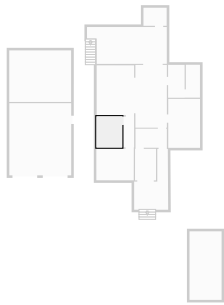

FLOORS: 2

▼ **Bedroom**
Ground Floor

WIDTH: 3.63 m • LENGTH: 3.06 m
AREA: 11.11 m² • PERIMETER: 13.38 m

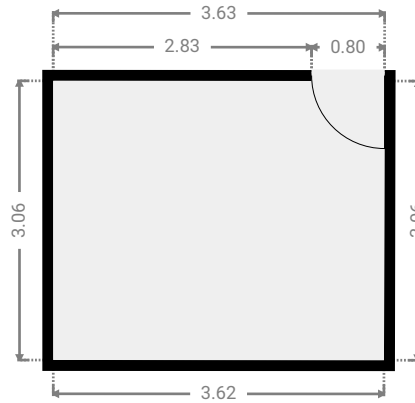
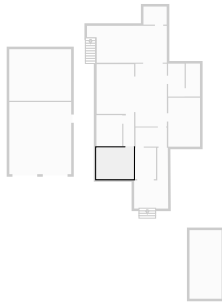

▼ **Garage**
Ground Floor

WIDTH: 6.00 m • LENGTH: 7.00 m
AREA: 42.00 m² • PERIMETER: 26.00 m

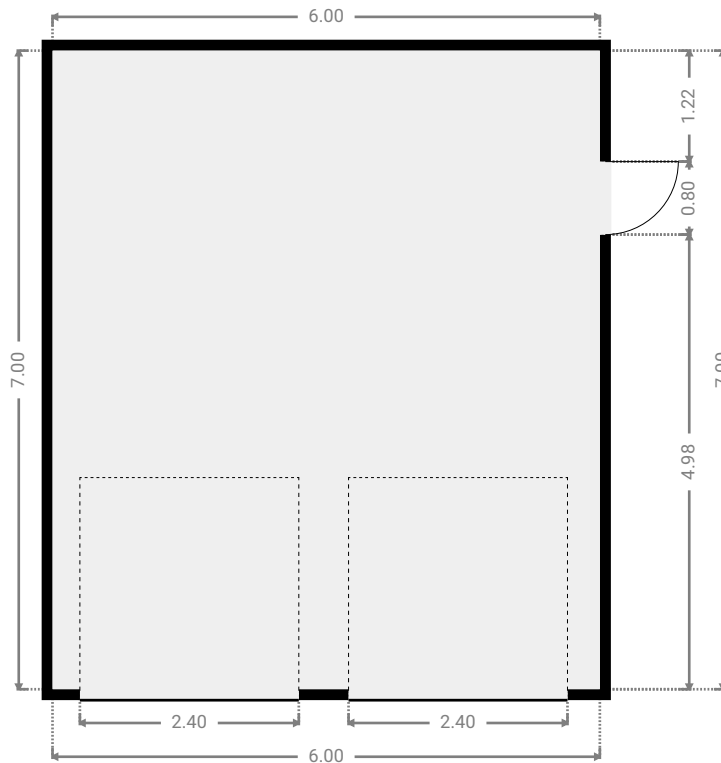
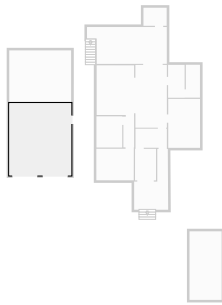

FLOORS: 2

▼ Garage Ground Floor

WIDTH: 3.11 m • LENGTH: 6.65 m
AREA: 20.68 m² • PERIMETER: 19.52 m

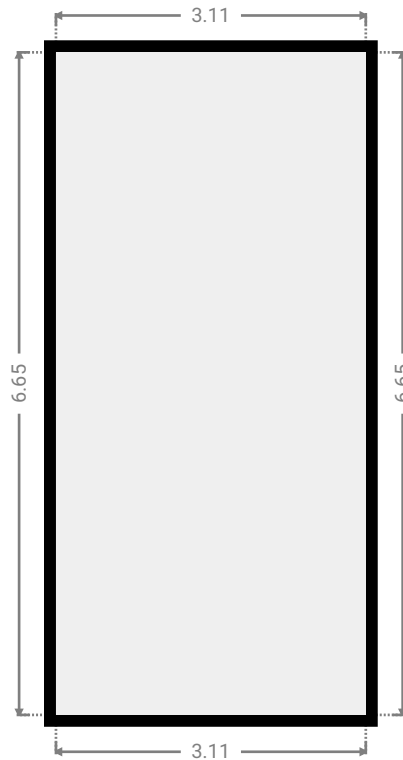
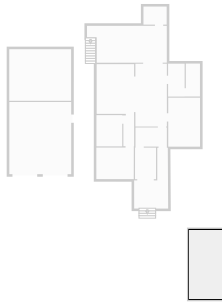

▼ Hall Ground Floor

WIDTH: 1.04 m • LENGTH: 2.98 m
AREA: 3.10 m² • PERIMETER: 8.04 m

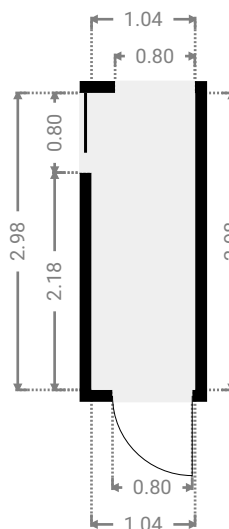
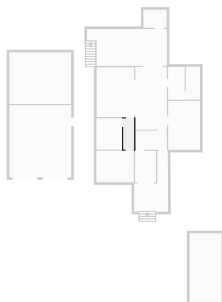

FLOORS: 2

▼ **Kitchen**
Ground Floor

WIDTH: 3.63 m • LENGTH: 4.82 m
AREA: 17.50 m² • PERIMETER: 16.90 m

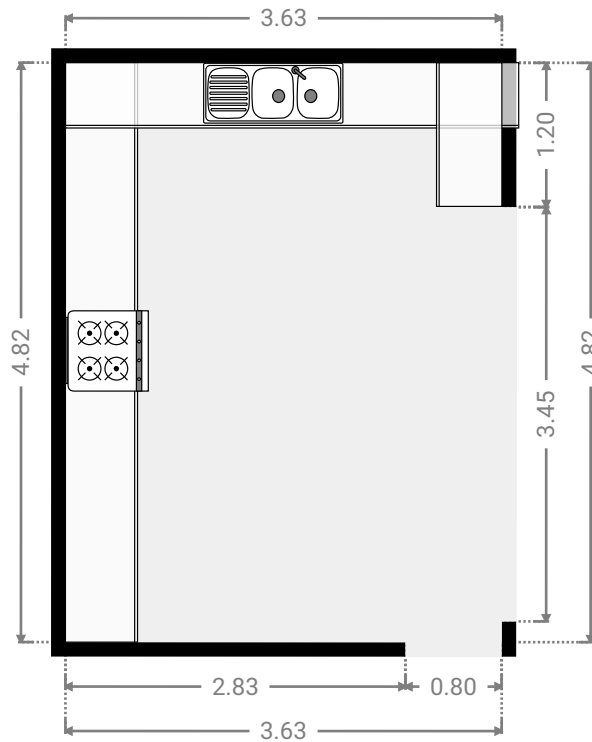
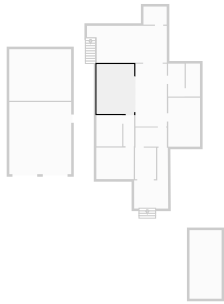

▼ **Laundry Room**
Ground Floor

WIDTH: 1.60 m • LENGTH: 3.19 m
AREA: 5.10 m² • PERIMETER: 9.58 m

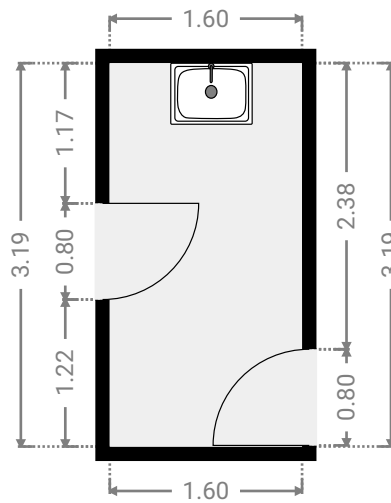
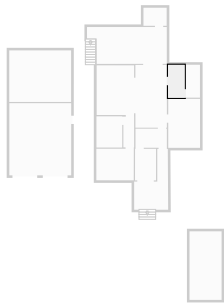

FLOORS: 2

▼ **Living Room**
Ground Floor

WIDTH: 3.05 m • LENGTH: 6.09 m
AREA: 18.57 m² • PERIMETER: 18.28 m

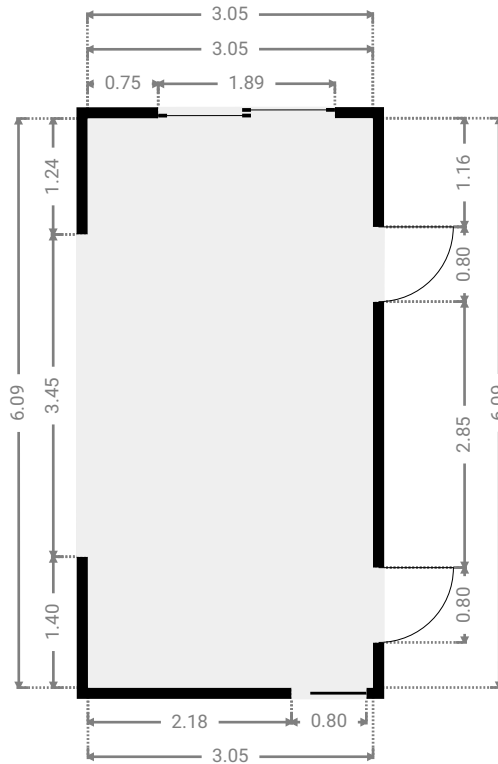
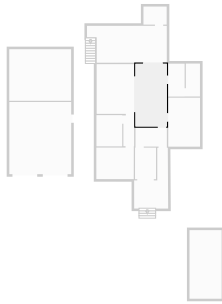

▼ **Other**
Ground Floor

WIDTH: 3.04 m • LENGTH: 1.85 m
AREA: 5.62 m² • PERIMETER: 9.78 m

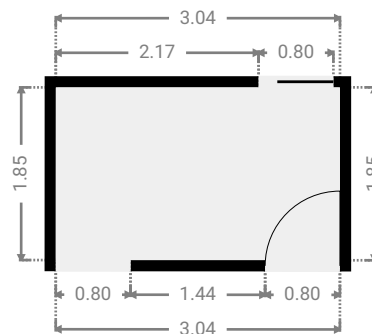
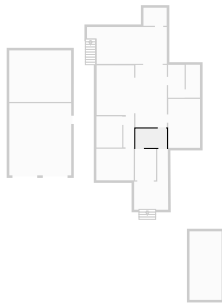

FLOORS: 2

▼ **Other**
Ground Floor

WIDTH: 7.74 m • LENGTH: 3.58 m
AREA: 25.34 m² • PERIMETER: 22.62 m

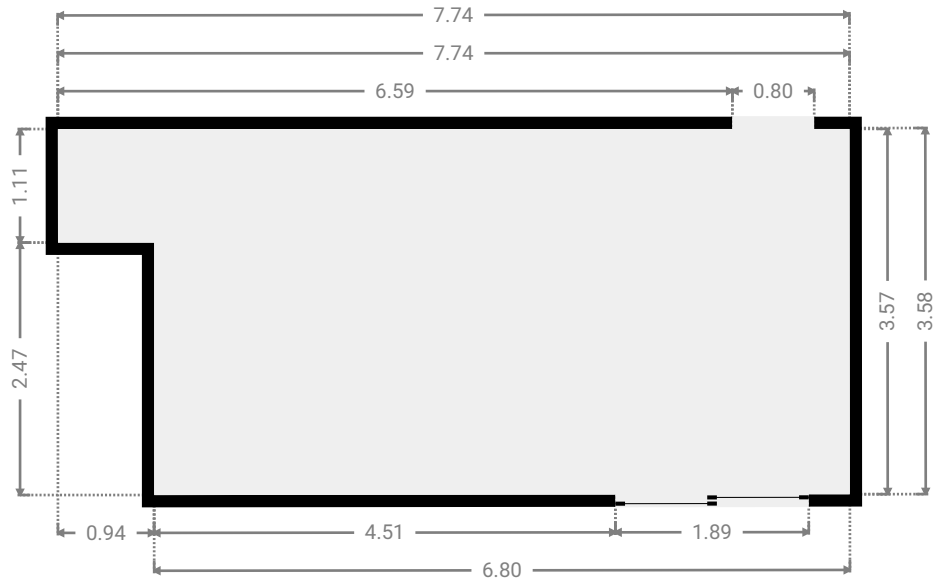
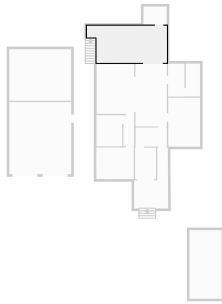

▼ **Closet**
Ground Floor

WIDTH: 2.25 m • LENGTH: 1.75 m
AREA: 3.94 m² • PERIMETER: 8.00 m

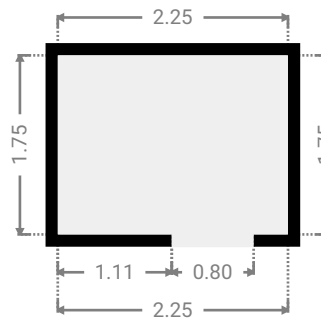

FLOORS: 2

▼ **Other**
Ground Floor

WIDTH: 6.00 m • LENGTH: 5.00 m
AREA: 30.00 m² • PERIMETER: 22.00 m

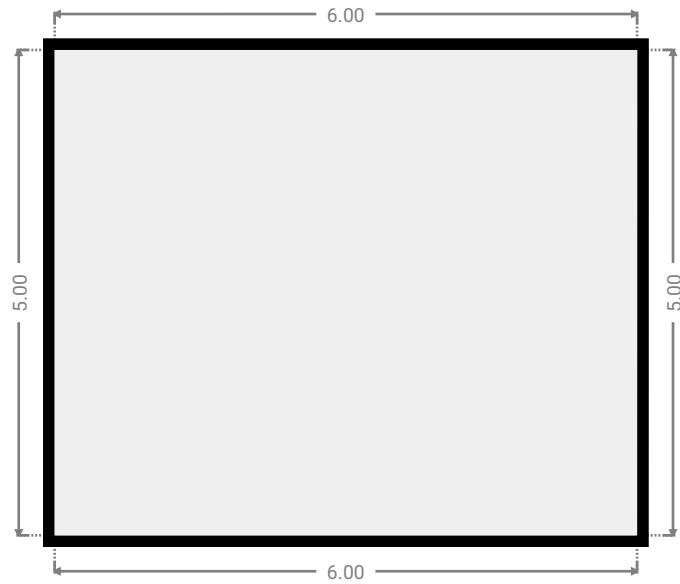
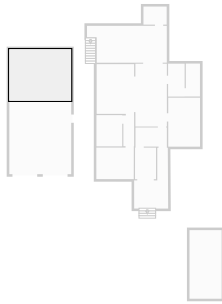

▼ **Other**
Ground Floor

WIDTH: 3.30 m • LENGTH: 5.90 m
AREA: 12.24 m² • PERIMETER: 18.36 m

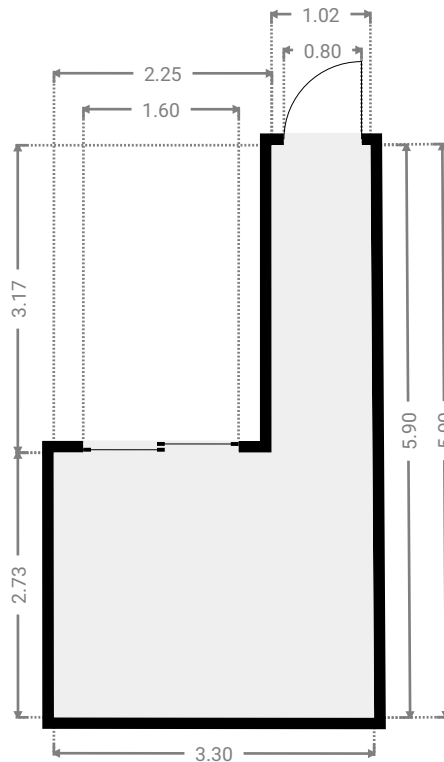
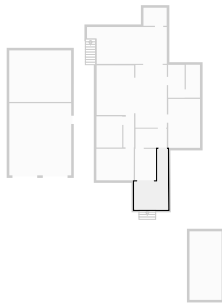

▼ 1st Floor



FLOORS: 2

▼ **Bathroom**
1st Floor

WIDTH: 2.00 m • LENGTH: 1.50 m
AREA: 3.00 m² • PERIMETER: 7.00 m

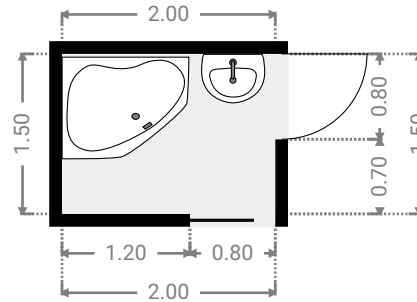
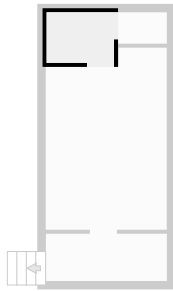

▼ **Living Room**
1st Floor

WIDTH: 3.59 m • LENGTH: 5.40 m
AREA: 18.15 m² • PERIMETER: 17.98 m

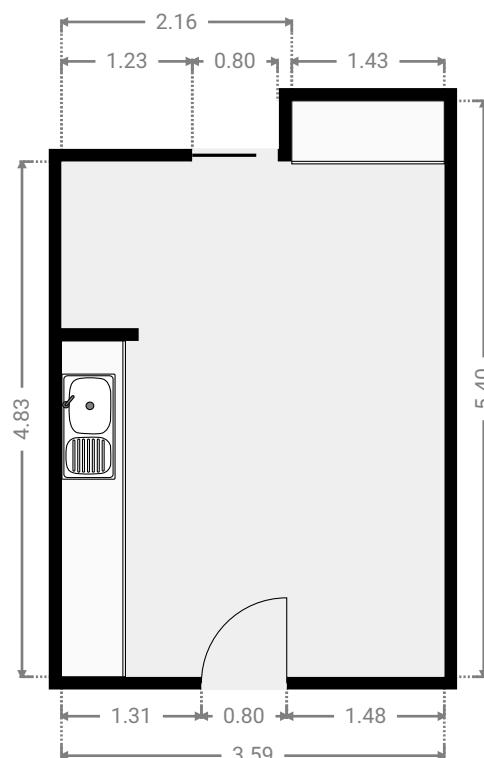
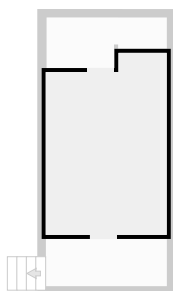

FLOORS: 2

▼ **Other**
1st Floor

WIDTH: 3.59 m • LENGTH: 1.40 m
AREA: 5.02 m² • PERIMETER: 9.98 m

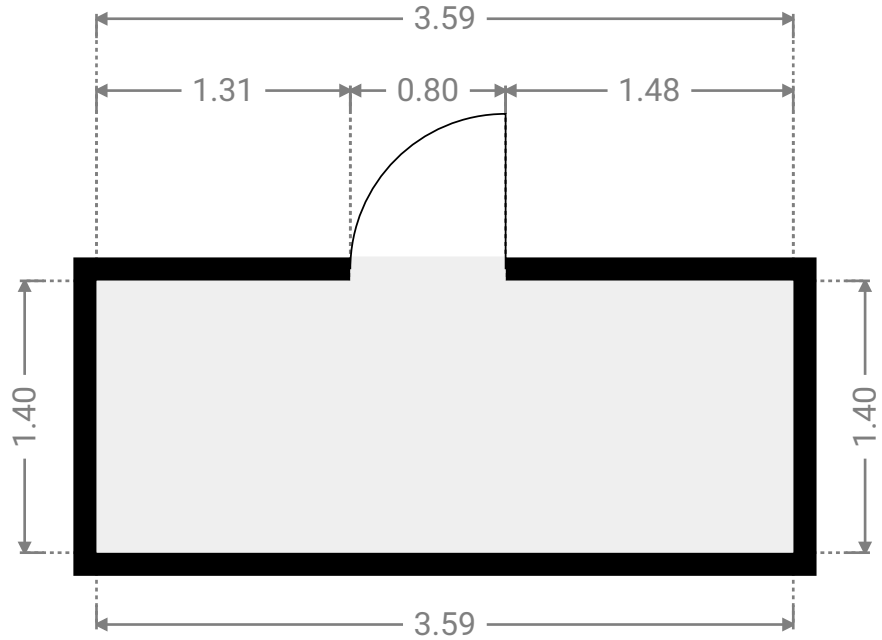
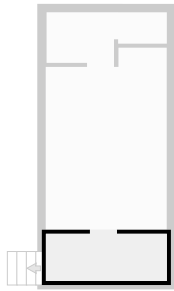

▼ **Toilet**
1st Floor

WIDTH: 1.44 m • LENGTH: 0.93 m
AREA: 1.34 m² • PERIMETER: 4.74 m

