

43 Jessie Street

Created on
2021-09-14

Floors
2

▼ Ground Floor

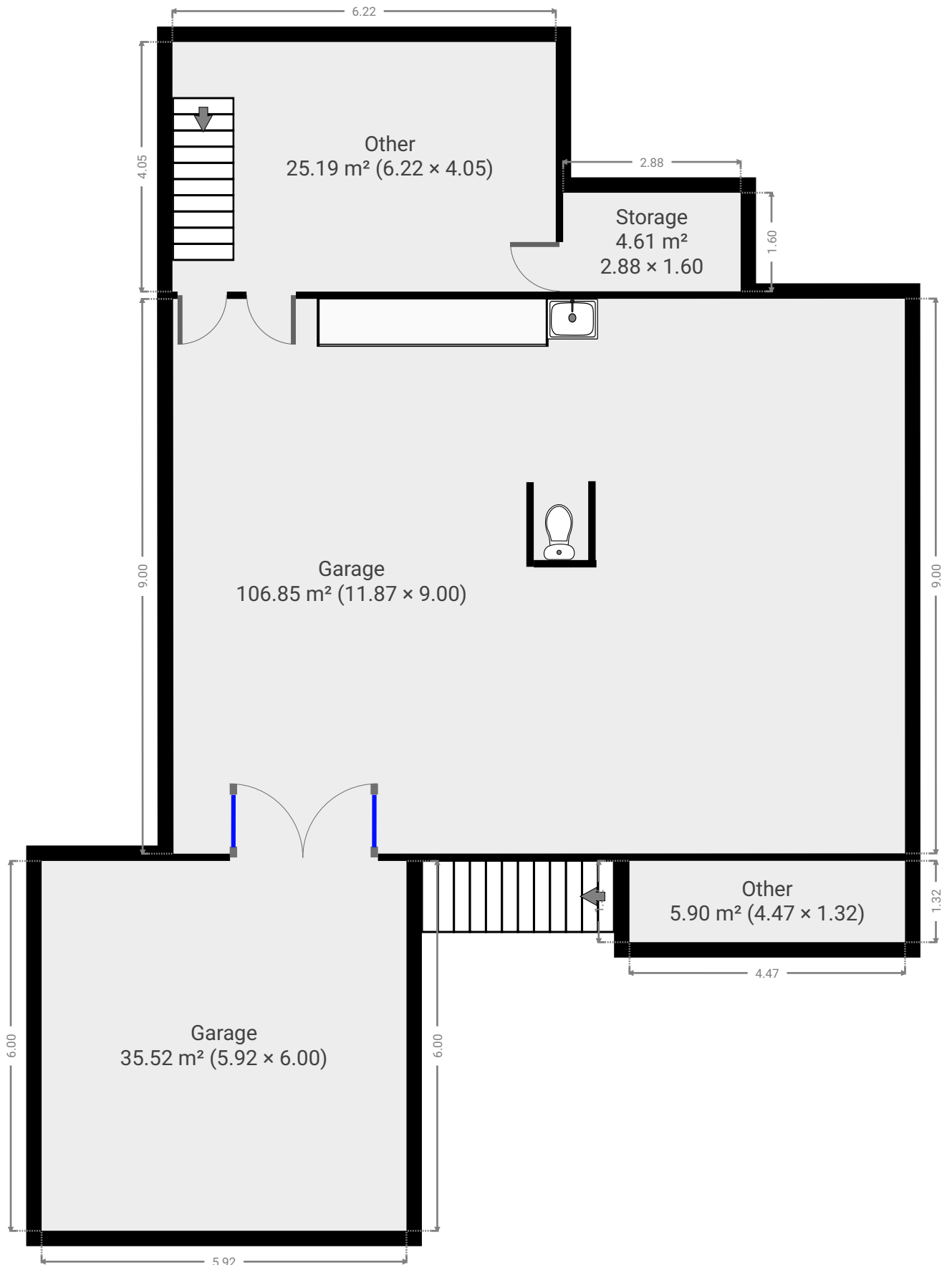

▼ Garage
Ground Floor

WIDTH: 11.87 m • LENGTH: 9.00 m
AREA: 106.85 m² • PERIMETER: 41.74 m

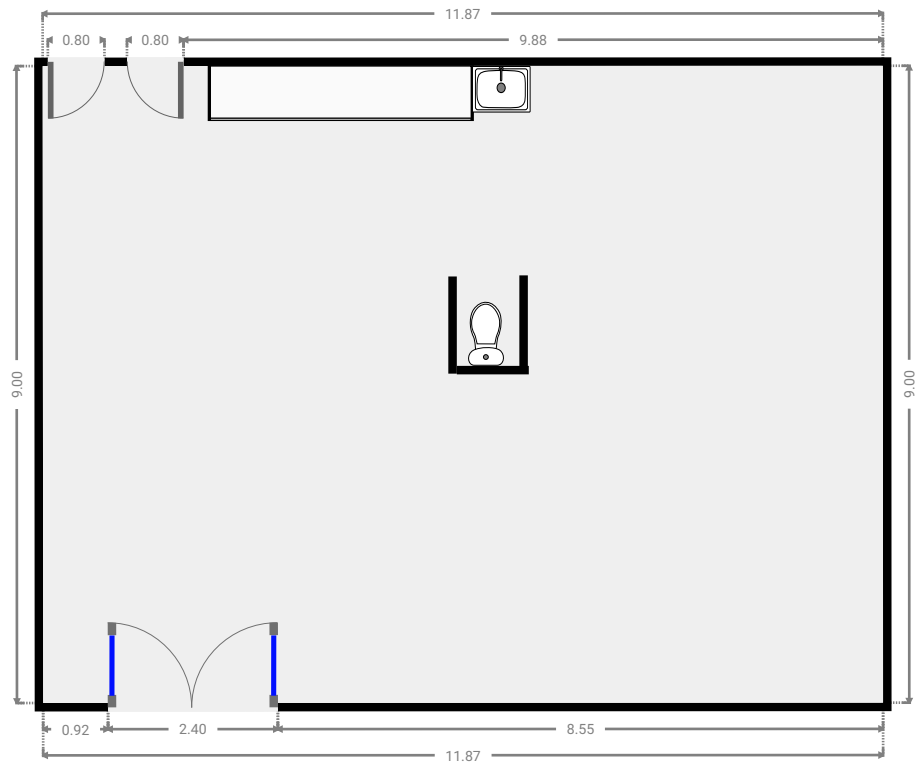
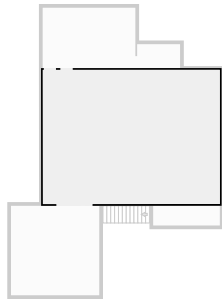

▼ Other
Ground Floor

WIDTH: 6.22 m • LENGTH: 4.05 m
AREA: 25.19 m² • PERIMETER: 20.54 m

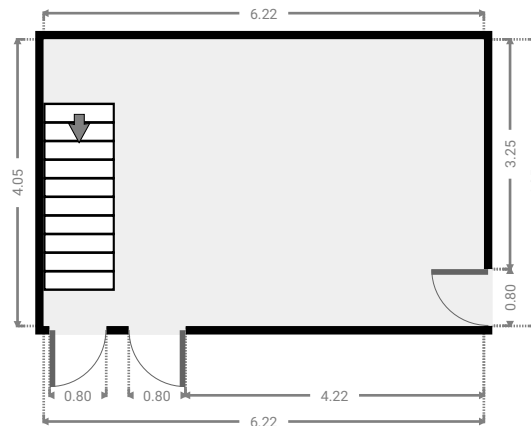
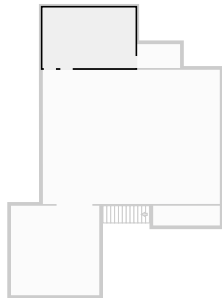

▼ Storage
Ground Floor

WIDTH: 2.88 m • LENGTH: 1.60 m
AREA: 4.61 m² • PERIMETER: 8.96 m

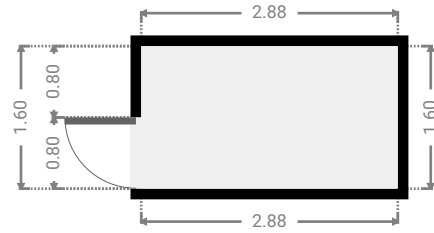
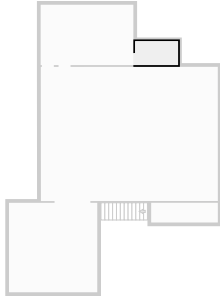

▼ Garage
Ground Floor

WIDTH: 5.92 m • LENGTH: 6.00 m
AREA: 35.52 m² • PERIMETER: 23.84 m

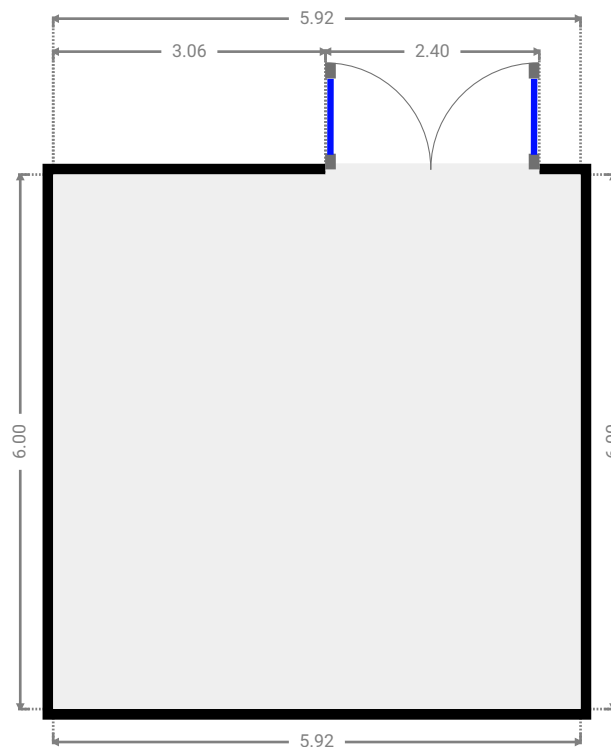
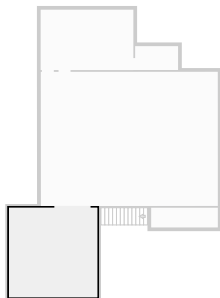

▼ Other
Ground Floor

WIDTH: 4.47 m • LENGTH: 1.32 m
AREA: 5.90 m² • PERIMETER: 11.58 m

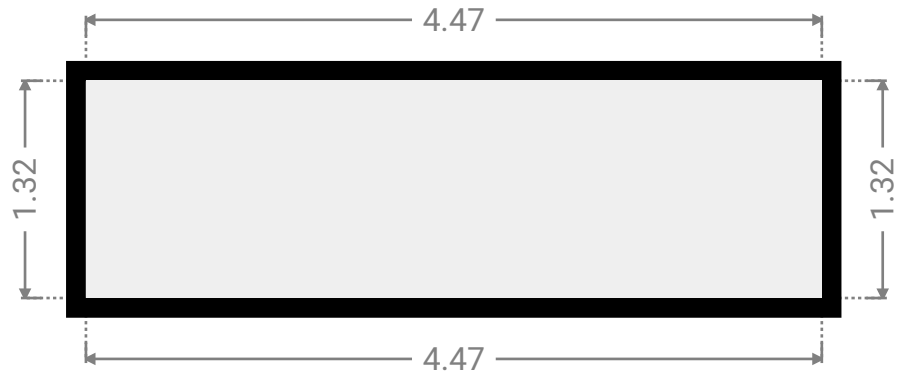
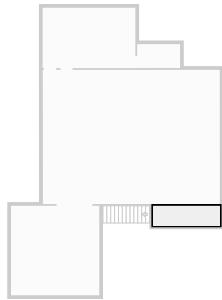

▼ 1st Floor

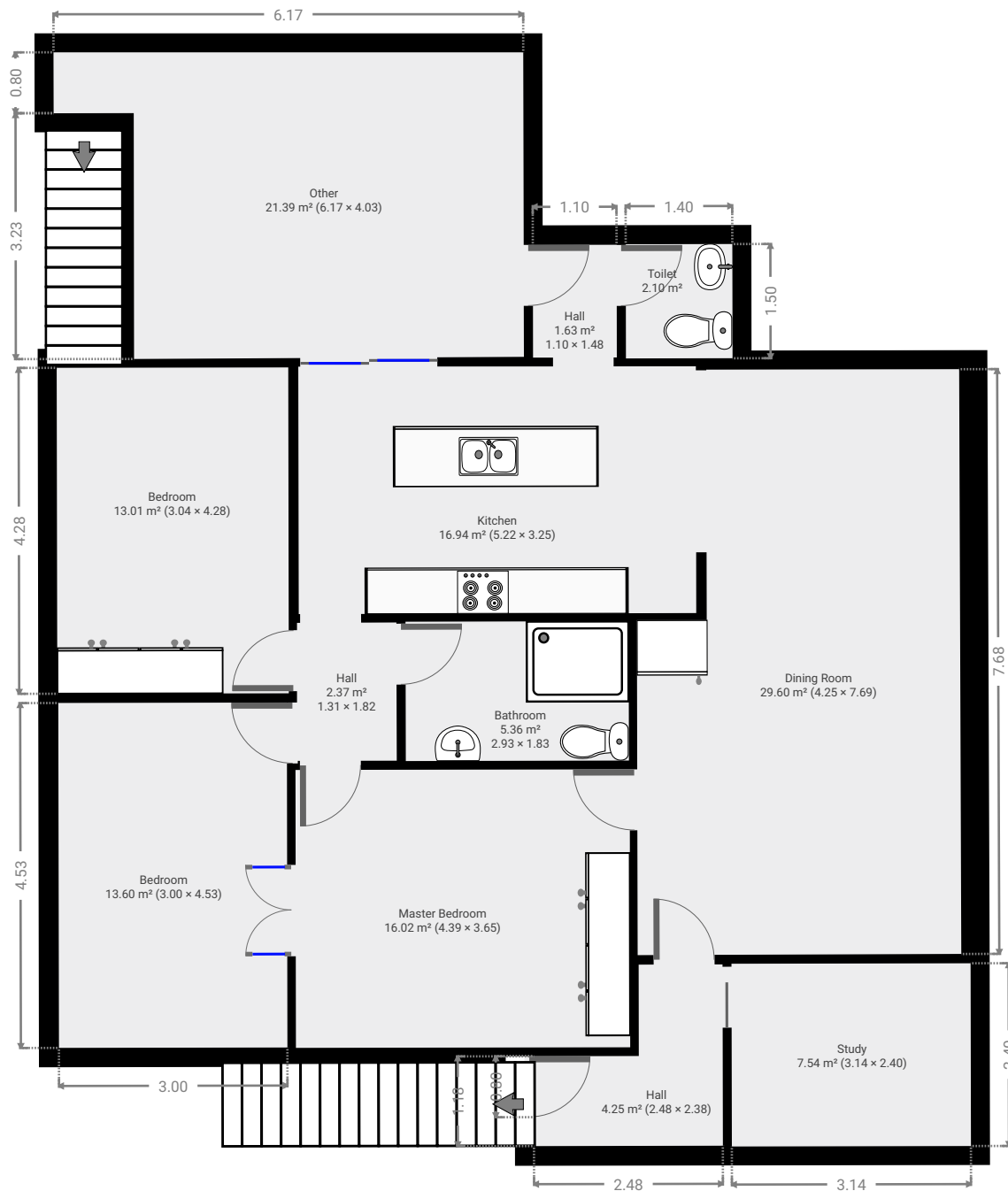

▼ **Hall**
1st Floor

WIDTH: 2.48 m • LENGTH: 2.38 m
AREA: 4.25 m² • PERIMETER: 9.72 m

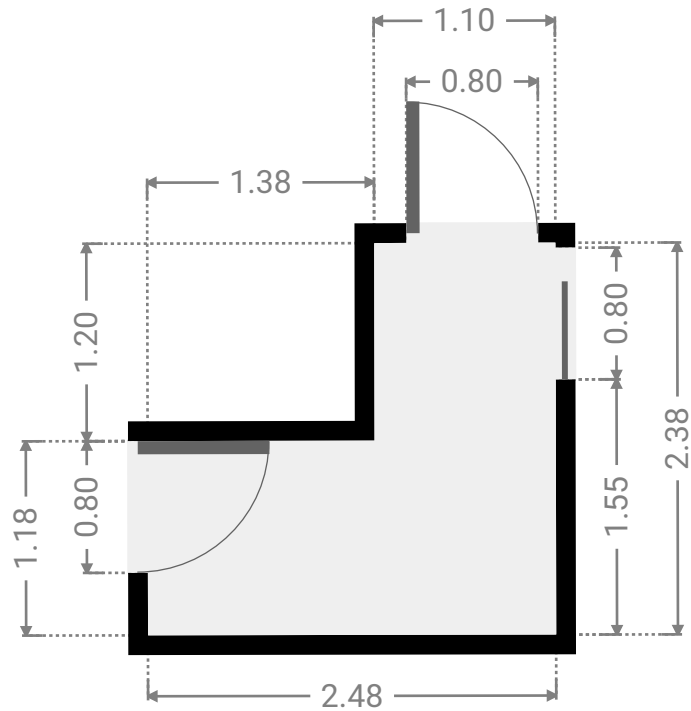
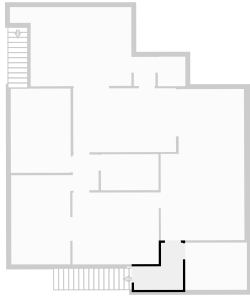

▼ **Study**
1st Floor

WIDTH: 3.14 m • LENGTH: 2.40 m
AREA: 7.54 m² • PERIMETER: 11.08 m

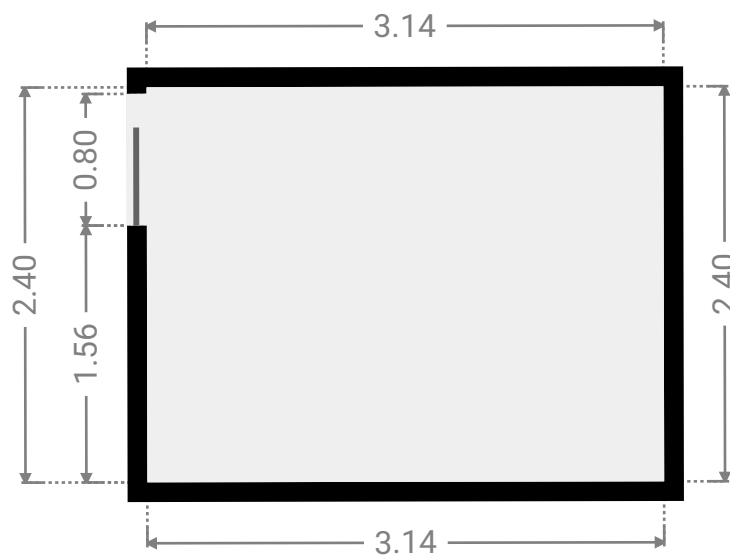
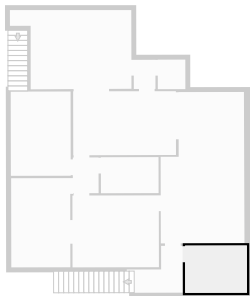

▼ Dining Room
1st Floor

WIDTH: 4.25 m • LENGTH: 7.69 m
AREA: 29.60 m² • PERIMETER: 23.85 m

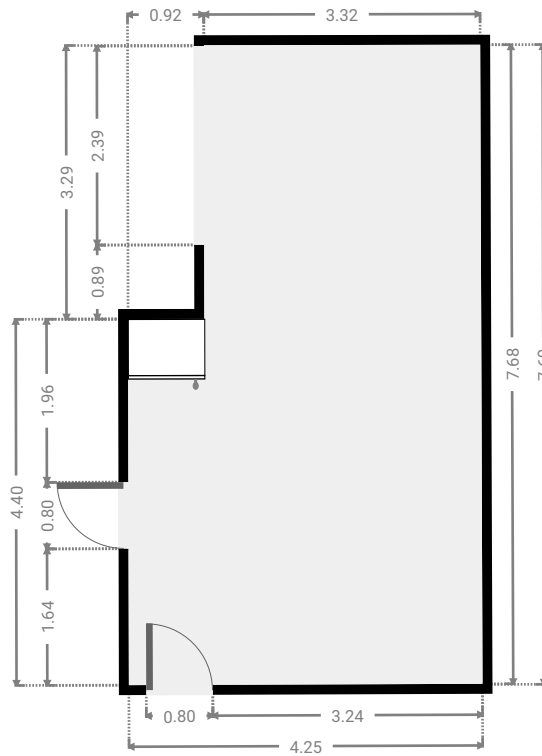
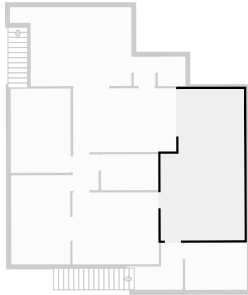

▼ Kitchen
1st Floor

WIDTH: 5.22 m • LENGTH: 3.25 m
AREA: 16.94 m² • PERIMETER: 16.93 m

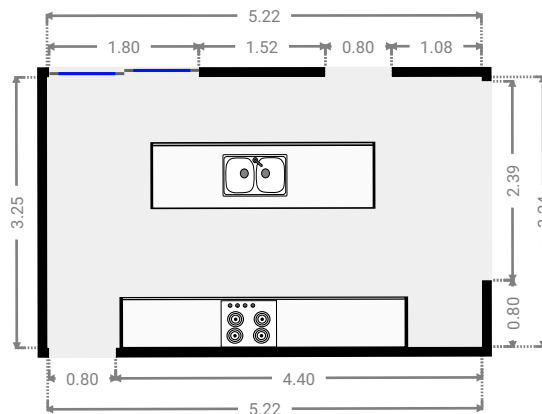
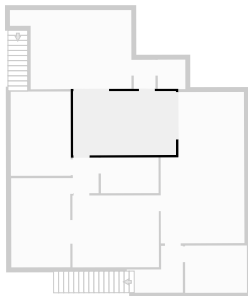

▼ **Hall**
1st Floor

WIDTH: 1.10 m • LENGTH: 1.48 m
AREA: 1.63 m² • PERIMETER: 5.16 m

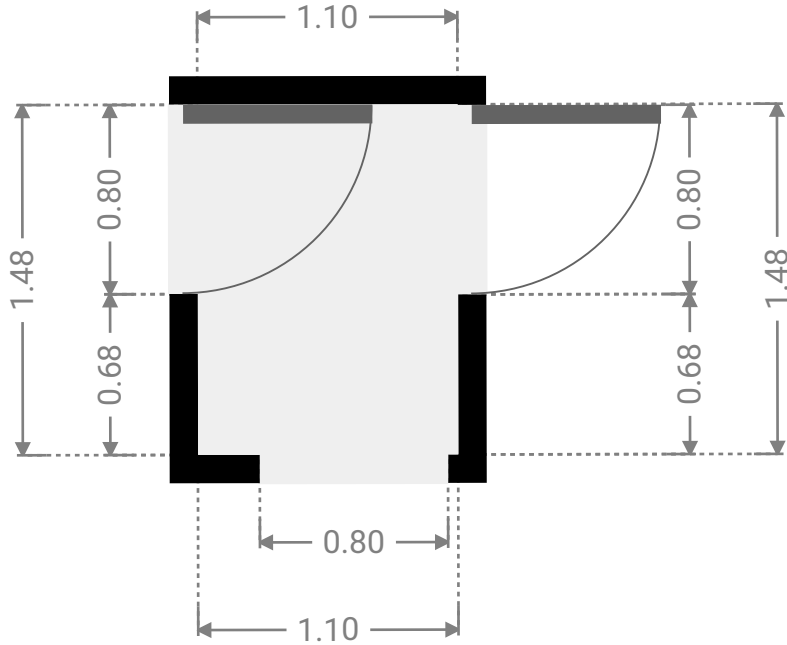
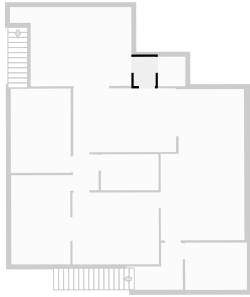

▼ **Toilet**
1st Floor

WIDTH: 1.40 m • LENGTH: 1.50 m
AREA: 2.10 m² • PERIMETER: 5.80 m

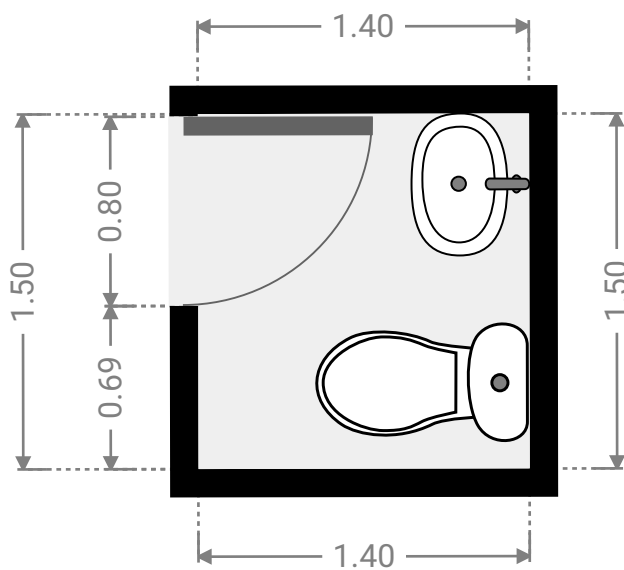
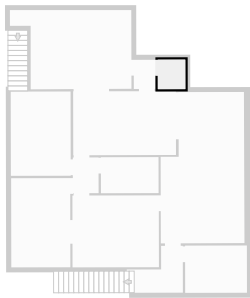

▼ **Master Bedroom**
1st Floor

WIDTH: 4.39 m • LENGTH: 3.65 m
AREA: 16.02 m² • PERIMETER: 16.08 m

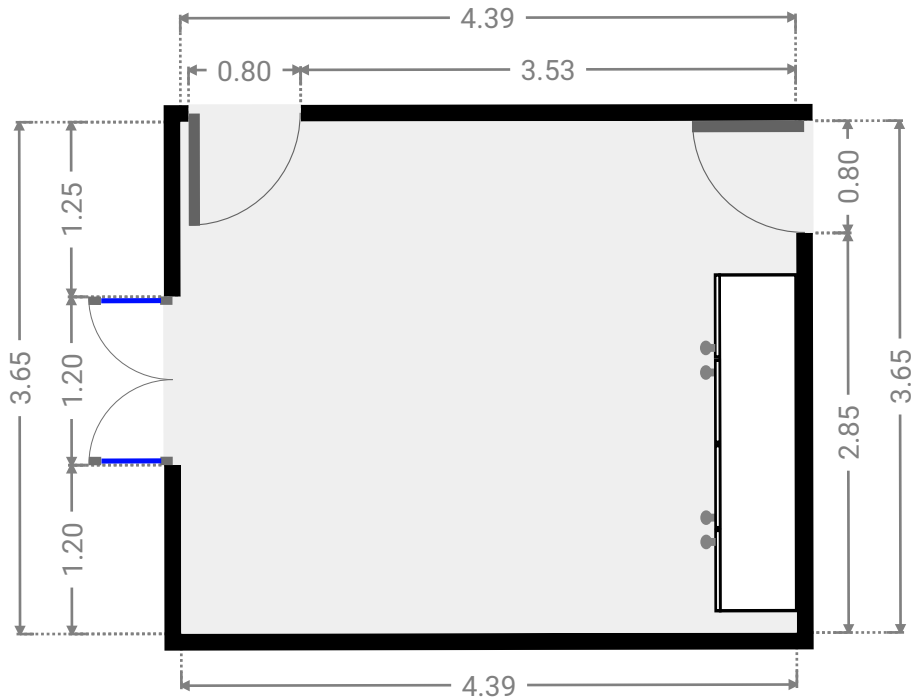
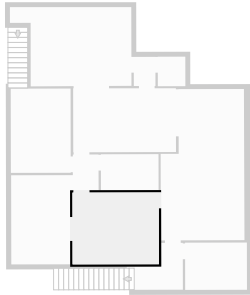

▼ **Bathroom**
1st Floor

WIDTH: 2.93 m • LENGTH: 1.83 m
AREA: 5.36 m² • PERIMETER: 9.52 m

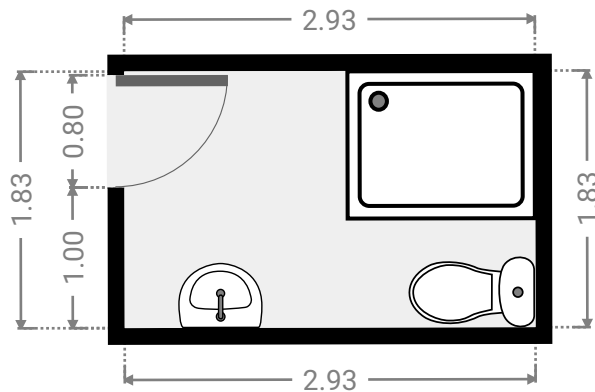
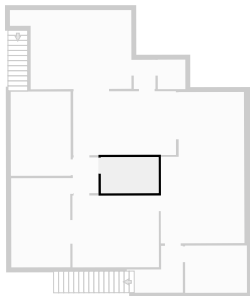

▼ **Hall**
1st Floor

WIDTH: 1.31 m • LENGTH: 1.82 m
AREA: 2.37 m² • PERIMETER: 6.24 m

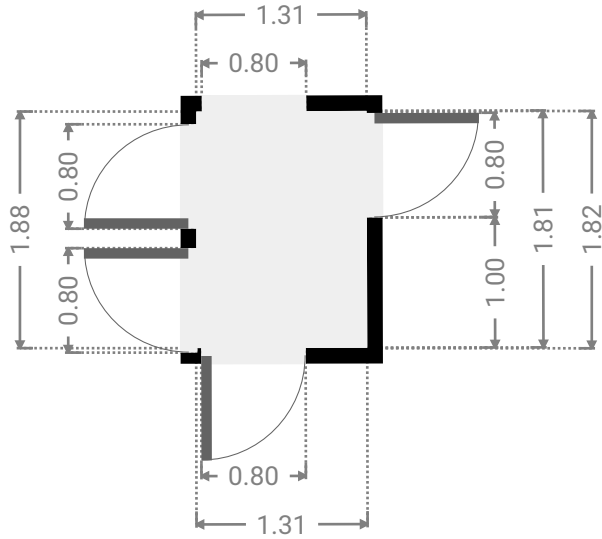
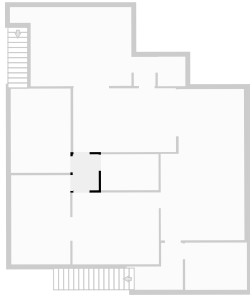

▼ **Bedroom**
1st Floor

WIDTH: 3.00 m • LENGTH: 4.53 m
AREA: 13.60 m² • PERIMETER: 15.06 m

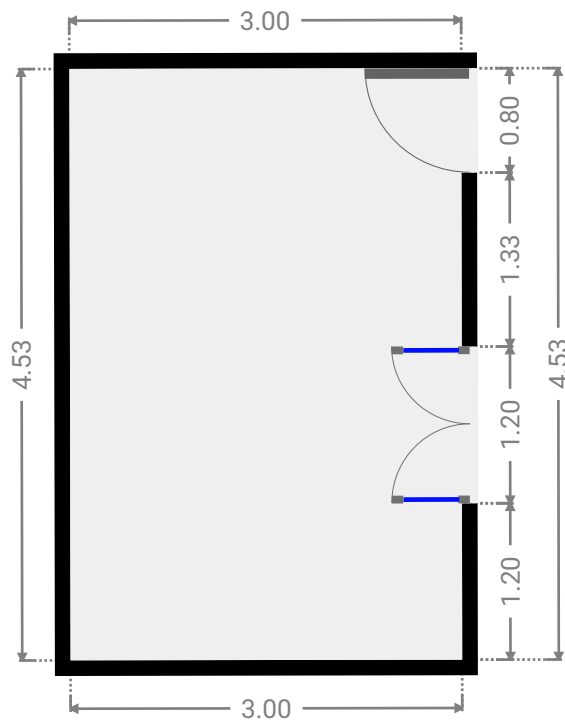
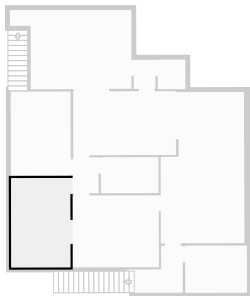

▼ **Bedroom**
1st Floor

WIDTH: 3.04 m • LENGTH: 4.28 m
AREA: 13.01 m² • PERIMETER: 14.64 m

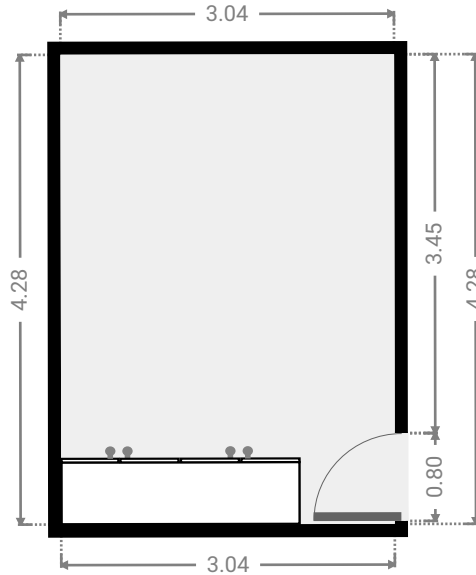
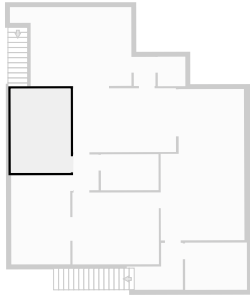

▼ **Other**
1st Floor

WIDTH: 6.17 m • LENGTH: 4.03 m
AREA: 21.39 m² • PERIMETER: 20.37 m

